



HEIDENHAIN



Operating Instructions

ND 1300 QUADRA-CHEK

(QC 320)

Optical Edge Detection and
Crosshair Systems

English (en)
2/2010

QC-300 Series

User's Guide

Optical Edge Detection Systems
QC-320, QC-321, QC-323, QC-324
QC-320E, QC-321E, QC-323E, QC-324E

QC-300 Series Optical Edge Detection and Crosshair Systems User's Guide

User's Guide part number: 11A10569 Revision 2
Publishing date: December, 2007
Printed in United States of America

QC-300 software version: 2.00

All information set forth in this document, all rights to such information, any and all inventions disclosed herein and any patents that might be granted by employing the materials, methods, techniques or apparatus described herein are the exclusive property of Metronics Inc., Bedford, New Hampshire.

Terms, conditions and features referenced in this document are subject to change without notice.

No part of this document may be reproduced, stored in a retrieval system, or transmitted in any form or by any means, electronic, mechanical, photocopying, recording, or otherwise, without prior written permission of Metronics, Inc.. Requests to Metronics, Inc. for permission should be addressed to the Technical Services Department, Metronics, Inc., 30 Harvey Road, Bedford, New Hampshire 03110.

Limit of liability and disclaimer of warranty

While this guide was prepared with great care, Metronics makes no representations or warranties with respect to the accuracy or completeness of the contents of this book and specifically disclaims any implied warranties of merchantability or fitness for a particular purpose. The advice, methods and instructions contained in this book might not be suitable for your situation. When in doubt regarding suitability, you are encouraged to consult with a professional where appropriate. Metronics shall not be liable for any loss of profit or any damages, including but not limited to special, incidental, consequential or other damages.

Trademarks

Metronics and QC-300 are registered trademarks of Metronics, Inc. and its subsidiaries in the United States and other countries.

Conventions & Terms

QC-300 refers to any of the QC-300 series of instruments. System refers to the QC-300 and the measuring devices connected to it.

Icons

This guide uses the following icons to highlight information:



WARNINGS

The raised hand icon warns of a situation or condition that can lead to personal injury or death. Do not proceed until the warning is read and thoroughly understood.



DANGEROUS VOLTAGE

The lightning icon warns of the presence of an uninsulated dangerous voltage within the product enclosure that might be of sufficient magnetude to cause serious shocks or death. Do not open the enclosure unless you are a qualified service person approved by Metronics, Inc., and never open the enclosure while power is connected.



CAUTIONS & IMPORTANT INFORMATION

The exclamation point icon indicates important information regarding equipment operation or maintenance, or a situation or condition that can lead to equipment malfunction or damage. Do not proceed until the information is read and thoroughly understood.



NOTE

The note icon indicates additional or supplementary information about an activity or concept.

Safety & Maintenance Considerations

General safety precautions must be followed when operating the system. Failure to observe these precautions could result in damage to the equipment, or injury to personnel.

It is understood that safety rules within individual companies vary. If a conflict exists between the material contained in this guide and the rules of a company using this system, the more stringent rules should take precedence.

Safety information is also included on the next page and in [Chapter 2: Installation](#).



WARNINGS

Disconnect the QC-300 from power before cleaning.

The QC-300 is equipped with a 3-wire power plug that includes a separate ground connection. Always connect the power plug to a 3-wire grounded outlet. The use of accessories that remove the third grounded connection such as a 2-wire power plug adapter create a safety hazard and should not be permitted. If a 3-wire grounded outlet is not available, ask your electrician to provide one.



DANGEROUS VOLTAGE

Do not open the enclosure unless you are a qualified service person approved by Metronics, Inc., and never open the enclosure while power is connected. There are no user-serviceable components or assemblies inside. Refer servicing to qualified service personnel.

General Maintenance

Disconnect the QC-300 from power and seek the assistance of a qualified service technician if:

- The power cord is frayed or damaged or the power plug is damaged
- Liquid is spilled or splashed onto the enclosure
- The QC-300 has been dropped or the exterior has been damaged
- The QC-300 exhibits degraded performance or indicates a need for service some other way

Cleaning the enclosure

Use only a cloth dampened with water and a mild detergent for cleaning the exterior surfaces. Never use abrasive cleaners, and never use strong detergents or solvents. Only dampen the cloth, do not use a cleaning cloth that is dripping wet. Instructions for cleaning the touch screen are different and are given below.

Cleaning the touch screen

The touch screen should be cleaned as described below to prevent scratching or wearing the screen surface and to prevent liquids from leaking into the enclosure.

Use only a soft, lint-free cloth dampened with water for cleaning the touch screen. Never use abrasive cloths or paper towels. Never use abrasive cleaners, and never use detergents or solvents. Only dampen the cloth, do not use a cleaning cloth that is dripping wet. Never spray the screen.

If the screen is badly soiled, the cloth can be dampened with a 50:50 mixture of isopropyl alcohol and water. Remember, only dampen the cloth, do not use a cleaning cloth that is dripping wet, and never spray the screen.

Contents

Chapter 1	Overview	
	Overview of the QC-300 features and functions	1
Chapter 2	Installation	
	Unpacking the QC-300	5
	Assembling the mounting stand.....	6
	Safety considerations	6
	Power cord and plug	6
	Electrical wiring and connections.....	6
	Location and mounting	7
	Power surge suppressor	7
	Connecting axis encoders	7
	Connecting a printer.....	8
	Connecting a computer	8
	Connecting an optional footswitch	9
	Connecting the optical edge detector inputs	9
	Connecting optional CNC outputs	10
	Warranty registration form	11
	Repackaging for shipment	11
Chapter 3	User Interface	
	Introduction.....	13
	Measurement functions.....	14
	Selecting a measurement type	14
	Accessing programming functions	15
	Sending data to a computer from the Extra tab	16
	CNC and other Extra tab functions.....	18
	Extra tab functions	18
	Space menu insert.....	18
	Divider line menu insert	18
	Data prompt function.....	18
	Optical edge detector probe calibration (probe teach).....	18
	Joystick motor speed	18
	Axis lock.....	18
	Part following	19
	Stop motion	19

Goto feature	19
Multiple Extra tabs	19
Command buttons and wide keys	20
Feature list.....	21
LCD Screen functions.....	22
Number keys	23
System functions.....	24
Datum lock.....	24
Undo	24
Probe.....	24
Magnification.....	25
Unit of measure.....	25
Setup	26
Printing reports and sending data.....	26
LCD ON/OFF and deleting feature data.....	27

Chapter 4 Quick Start Demonstration

Start recording a program	30
Select a probe.....	30
Create part skew and datum references	31
Measuring a part skew	31
Create a datum zero point	32
Probing a datum zero point.....	32
Constructing a datum zero point.....	33
Measure a feature.....	35
Measuring a circle.....	35
Apply tolerances to a feature measurement.....	37
Print a report	39
Stop program recording	40
Running the program	41

Chapter 5 Probes

Probes.....	44
Edge detector probes.....	44
Automatic point entry	44
Manual point entry.....	44
Crosshair probes	44
Automatic point entry	45
Manual point entry.....	45
Preparing to use probes.....	46
System and part condition	46

Selecting a magnification	46
Lighting.....	46
Calibration	47
Edge teach	47
Distance calibration.....	47
Cross calibration.....	47
Probing with edge detectors.....	48
Automatic point entry	48
Manual point entry.....	49
Probing with crosshairs.....	50
Automatic point entry	50
Manual point entry.....	50

Chapter 6

Measuring

Measurement activities	52
The measurement process.....	52
Establishing the measurement reference	53
Leveling the part (optional).....	53
Skewing the part.....	54
Creating a datum zero point	55
Probing a datum zero point	55
Constructing a datum zero point	56
Probing and measuring features.....	58
Probing with Measure Magic.....	58
Probing specific feature types.....	59
Probing a single specific feature type.....	59
Probing multiple specific feature types	59
Probing process.....	60
Supported feature types	60
Backward/forward annotation	61
Probing with crosshairs and optical edge detection.....	61
Probing specific feature types.....	62
Probing points.....	62
Probing lines.....	63
Probing arcs	64
Probing slots	66
Probing rectangles	67
Probing distances.....	68
Probing angles	69

Constructing features	70
Point constructions.....	70
Point constructed from a point	70
Point constructed from a point and a line	70
Points constructed from an arc and a line.....	71
Points constructed from a line	72
Point constructed from two lines.....	73
Points constructed from a distance	73
Point constructed from a distance and a point.....	74
Point constructed from a circle.....	74
Points constructed from a circle and a line.....	75
Points constructed from two circles	76
Point constructed from a slot.....	77
Point constructed from a rectangle	77
Point constructed from an angle	77
Point constructed from an arc.....	78
Point constructed from multiple features	78
Line constructions.....	79
Line constructed from a line.....	79
Line constructed from two points.....	79
Lines constructed from a point and a line	80
Line constructed from a distance.....	80
Lines constructed from a point and a circle.....	81
Line constructed from a point and a slot	82
Line constructed from a point and a rectangle	82
Lines constructed from a point and an arc.....	83
Lines constructed from two lines	84
Line constructed from a line and a distance	85
Lines constructed from a line and a circle.....	85
Lines constructed from a line and a slot.....	86
Lines constructed from a line and an arc.....	86
Line constructed from a line and an angle.....	87
Lines constructed from a line and a rectangle	87
Lines constructed from two circles.....	88
Lines constructed from a circle and an arc.....	89
Lines constructed from a circle and a slot.....	90
Line constructed from a slot.....	91
Line constructed from two slots	91
Lines constructed from a rectangle and a circle	92
Lines constructed from a slot and an arc	93
Lines constructed from a rectangle and an arc	94
Lines constructed from a slot and a rectangle	95

Lines constructed between two rectangles	95
Line constructed from a rectangle	97
Line constructed from multiple features.....	97
Distance constructions	98
Distance constructed from a distance	98
Distances constructed from two points.....	98
Distances constructed from a point and a line.....	99
Distances constructed from a point and a rectangle	99
Distances constructed from a point and a circle.....	100
Distance constructed from a point and a slot.....	101
Distances constructed from a point and an arc	102
Distance constructed from a line	103
Distance constructed from a line and a rectangle	103
Distances constructed from two lines.....	104
Distances constructed from a line and a circle	105
Distances constructed from a line and an arc	106
Distance constructed from a line and a slot.....	107
Distance constructed from two distances	107
Distances constructed from two circles.....	108
Distances constructed from a slot and a circle	109
Distances constructed from a rectangle and a circle.....	109
Distances constructed from an arc and a circle	110
Distance constructed from two slots.....	111
Distances constructed from a slot and an arc	111
Distances constructed from a rectangle and an arc.....	112
Distances constructed from a slot and a rectangle.....	112
Distances constructed between two rectangles.....	113
Distances constructed from two arcs	114
Circle constructions	115
Circle constructed from a circle	115
Circles constructed from two lines.....	115
Circle constructed from a circle and a distance.....	116
Circle constructed from two circles.....	116
Circle constructed from multiple features	117
Arc constructions	118
Arc constructed from an arc	118
Arc constructed from an arc and a distance.....	118
Angle constructions	119
Angle constructed from an angle.....	119
Angle constructed from two lines.....	120

Creating features	121
Creating a point.....	121
Creating a line.....	122
Creating a circle.....	122
Creating an arc	123
Creating a slot.....	123
Creating a rectangle.....	124

Chapter 7 Tolerancing

Applying tolerances to features	127
Selecting a feature.....	127
Displaying the tolerance screen	127
Selecting a tolerance type	127
Selecting a specific tolerance.....	128
Entering nominal, limit or tolerance values.....	128
Omitting a tolerance category	129
Tolerance types.....	130
Bidirectional	130
Points	130
Lines	130
Circles and arcs	131
Slots and rectangles.....	131
True position.....	132
Points and lines.....	132
Circles and arcs	132
MMC/LMC (Material condition)	133
MMC Circles and arcs.....	133
LMC Circles and arcs.....	134
Runout	135
Roundness.....	135
Concentricity	135
Straightness.....	135
Parallelism	136
Perpendicularity.....	136
Angle	136
Width	137

Chapter 8 Programming

Creating programs.....	139
Start program recording.....	140
Enter a program title (or user message).....	141
Measure a skew and create a datum	142
Measure a feature (include a message).....	142
Apply a tolerance.....	143
Report results.....	143
Stop the program recording	144
Specifying part fixturing (CNC option).....	145
None	145
Temporary	145
Permanent	145
Editing Programs	146
Editing existing steps.....	146
Editing program settings	146
Editing tolerances.....	148
Editing user prompt messages.....	149
Inserting or appending new program steps.....	150
Running programs	152
Saving and retrieving programs.....	153
Saving programs.....	153
Retrieving programs	153
Deleting programs	155

Chapter 9 Communication

Connecting to a computer.....	157
Sending data to a computer.....	158
Connecting a printer.....	159
Printer format strings.....	159
Report formats	159
Printing a report.....	160
Printing feature measurement data	160
Printing QC-300 system settings	161
RS232 connector pin designations.....	162
ASCII Code table.....	162

Chapter 10 Setup

The Setup Menu	164
Accessing and using the Setup Menu	164
Entering the supervisor password.....	165
Selecting items from the Setup Menu	166
Selecting setup parameter choices.....	166
Entering and deleting setup data.....	166
Storing a parameter and advancing to the next step	167
Leaving the setup menu.....	167
Minimum setup requirements	168
Setup screen descriptions	169
Language screen	169
Specifying the displayed language	169
Supervisor screen	170
Entering the supervisor password.....	170
Keeping setup privileges until the power is cycled	170
Hiding setup parameters from unauthorized personnel	170
Limiting access to program functions.....	170
Saving and loading settings	171
Encoders screen	172
Selecting an axis to configure.....	172
Specifying encoder resolution	172
Specifying encoder type	172
Selecting reference marks.....	173
None	173
Manual.....	173
Single.....	173
Absolute.....	173
Setting a new machine zero reference	174
Reversing the encoder count direction	174
Enabling axis error messages.....	174
Specifying slew limit.....	174
Squareness screen	175
SLEC screen.....	176
LEC or SLEC, which is right for my application?	176
LEC (Linear error correction).....	176
SLEC (Segmented linear error correction).....	178
NLEC Screen	181
.acf Files.....	181
.acf file format	181
Example 3 X 3 grid.....	181

Example .acf file.....	181
Calibrating from features.....	182
Calibrating NLEC by adjusting station values	184
Calibrating NLEC with existing NLEC correction text file	185
Magnifications screen	186
Adding magnifications.....	186
Deleting magnifications.....	186
Edge calibrations for routine measurements.....	187
Edge calibrations for difficult measurements	187
Specifying an active edge detection zone for program playback	188
Evaluating optical light levels	188
Calibrating crosshair and edge probe offset	188
Performing parcentric calibrations	189
Measure screen.....	191
Annotation	191
Minimum points required for a feature measurement	191
Locking features to their original datums	192
Specifying signed distances.....	192
Enabling and configuring point filtration	192
Enabling point filtration	193
Specifying a filtration error limit.....	193
Specifying a filtration standard deviation range.....	193
Specifying the minimum percentage of retained points.....	193
Crosshair timeout delay	194
Crosshair delay restart distance	194
Display screen.....	195
Display resolution.....	195
Default units of linear measure.....	196
Radix for numeric displays.....	196
Angular units of measure.....	196
Time formats.....	196
Date formats.....	196
Display mode switching	197
Configuring the Extra tab	198
Extra tab functions.....	199
Space menu insert.....	199
Divider line menu insert.....	199
Data prompt function.....	199
Optical edge detector probe calibration (probe teach).....	199
Joystick motor speed	199
Axis lock.....	199
Part following	199

Stop motion	200
Goto feature	200
Header screen.....	201
Creating report headers.....	201
Print screen.....	202
Specifying a data type.....	202
Specifying a data destination	202
Report Type	202
Lines per page.....	202
Specifying column separators.....	203
Selecting a USB printer	203
Ports screen	204
Baud rate.....	204
Word length	204
Stop bits	204
Parity.....	204
EOC delay.....	204
EOL delay	204
Clock screen.....	205
Sound screen	206
Miscellaneous screen	207
Return to DRO threshold	207
Touchscreen calibration rows and columns.....	207
Calibrating the touchscreen	208
Touch screen cursor.....	208
Touch screen repeat delay	208
Touch zone size	209
Screen brightness	209
Showing the Extra tab.....	209
Buttons screen.....	210
Selecting button functions	210
Selecting button responses.....	211
Selecting button logic	211
Joystick screen	212
Enabling joystick motion.....	212
Specifying a joystick deadband	212
Specifying axis direction	212
Specifying normal and fine axis velocity	212
Specifying linear and nonlinear joystick motion control.....	213
Calibrating the Joystick range of motion.....	213

Digital positioner screen	214
Enabling digital positioner motion	214
Specifying axis direction	214
Specifying normal and fine axis velocity	214
Specifying axis acceleration	214
Specifying a digital positioner counter debounce.....	214
Current value display	214
Probe path screen	215
Probing and non-probing velocities	215
Approach and search distances	216
Edge values screen	217
Debouncing edges	217
Viewing current edge detector values.....	217
Hardware screen.....	218

Chapter 11 Problem Solving

Symptoms, probable causes and solutions.....	220
No image is visible on the LCD screen	220
Values displayed on the LCD screen are incorrect.....	220
Reports are not printed or are incomplete.....	222
Reports are printed incorrectly	222
Optical edge detection is not working properly.....	223
Data cannot be transmitted to a computer	224
Getting help from your distributor	224

Chapter 12 Reference Material

Product specifications	225
Electrical	225
Environmental.....	225
Dimensions	225
LCD	225
ENC tests	225
Footswitch wiring	226
RS-232 connector wiring	227
Tolerance definitions	228
Concentricity tolerance	228
Reference Features.....	228
Least squares best fit.....	228
Maximum inscribed circle	228
Minimum superscribed circle	228
ISO (least radial distance).....	228

Chapter 13 Product Options

List of product options 229

Chapter 1: Overview

The Quadra-Chek 300 series is a family of advanced digital readout systems for performing 2, 3 and 4 axis measurements at very high levels of precision and accuracy. Dimensional inspection of components can be made using comparator or toolmaker's microscope systems as part of in-line production activities or final quality inspection.

Feature points are entered using crosshairs or (optional) optical edge detection. Feature type can automatically be determined by the system using Measure Magic. Level and skew compensation can be performed on misaligned parts prior to measurements to eliminate the need for time-consuming fixturing.

Sequences of key-presses used to perform measurements can be recorded and stored as programs. These programs can be replayed later to perform complete measurement sequences. Sequences can be as simple as measuring a line, or can be expanded to include skew adjustment, datuming, the measurement of multiple features, tolerancing and printing reports of measurement results. Programs can include the CNC motion control option to fully automate program execution, increase throughput and simplify operator tasks.

The intuitive interface will be familiar to users of the QC-200 and other Metronics digital readouts. Operators will find the QC-300 easy to understand and use thanks to the large color touch screen LCD display.

The color LCD displays alphanumeric and graphic information for the current measurement, part features and measurement data clearly on one screen, eliminating the need to page or scroll for information.

Touch screen controls select the feature to be measured, change operating and display modes, zero axes, and configure setup parameters. Touch screen controls change to support measurement-specific functions displayed on the LCD screen.





Front panel keys enter numeric data, turn the LCD on or off and send data to a printer or computer. Two wide keys located over the LCD can quickly be pressed without looking at the front panel to initiate frequently used functions programmed by the user. All front panel keys provide tactile sensory feedback, and key-press operations can be configured to generate an audible sound.

Speaker and external speaker jack outputs are provided that can be adjusted for quiet or noisy environments. Ear phones can be plugged into the external speaker jack to facilitate silent operation in quiet environments.

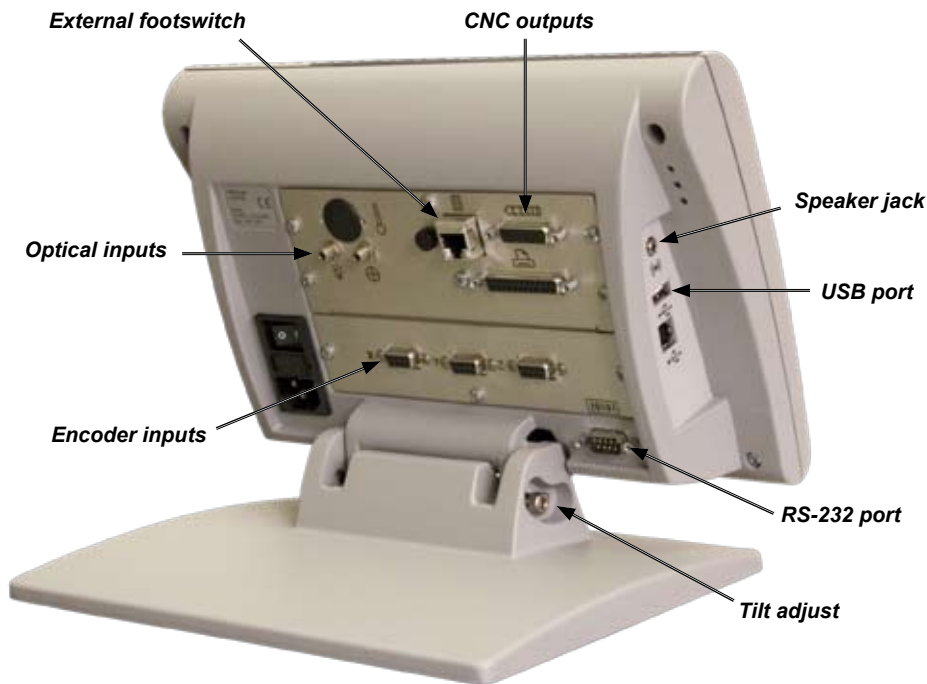

Measurements viewed on the LCD can be transmitted to a PC over USB or RS-232 ports or to a printer over the USB port.

The compact ergonomic design and adjustable-tilt front panel of the QC-300 allow users to locate and mount the instrument in a wide variety of environments that accommodate nearly any viewing requirement. The tilt front panel can be adjusted and secured in any convenient position. Rubber feet on the bottom prevent slipping when the system is not permanently bolted to a work surface using the bolt holes provided in the mounting stand.

Jacks are provided for optional optical edge detection inputs and for an optional foot switch. All the optional accessories for the QC-300 are shown in detail at the rear of this guide in [Chapter 13: Options](#).

Chapter 2:

Installation

The QC-300 is easy to install in a variety of basic and advanced measurement applications. This chapter describes how to unpack and install the QC-300. Repackaging instructions are also included for return shipments and for distributors and OEM customers that are configuring a QC-300 and shipping it to an end-user.

Unpacking the QC-300

Carefully remove the contents of the shipping carton.



NOTE

Save the carton and packaging materials in case future return shipment becomes necessary.

Inspect the components listed below for shipping damage. The contents of the carton includes:

- QC-300 instrument
- Power cord
- Mounting stand and hardware
- Warranty registration card

Shipments of other optional equipment in separate cartons might include:

- Optical cables and press-clip
- RS-232 serial cable
- Foot switch
- Plexiglas cable holder
- CNC output cable
- Taltech's WinWedge® software

If any components were damaged in shipment, save the packaging materials for inspection and contact your shipping agent for mediation. Contact your Metronics distributor for replacement parts.

Assembling the mounting stand

The QC-300 is secured to the swivel slots of the mounting stand by a shoulder screw, a cap screw and associated washers.

Assemble the QC-300 to the mounting stand as shown. Tighten the shoulder screw (1), and then tighten the cap screw (5) and washers (3 & 4) so that the QC-300 will be secure when adjusted to the desired tilt position.

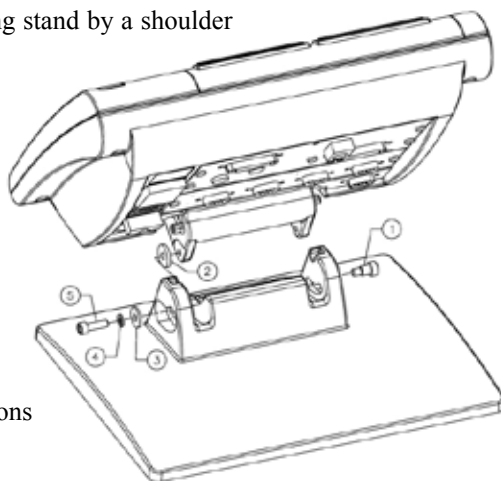

Safety considerations

The QC-300 is completely enclosed and no hazardous outputs can come in contact with the user. Safety considerations are related to power connections and physical mounting.



WARNING

If the QC-300 falls from its mounting location, serious personal injury or damage to the equipment can result.

Power cord and plug

Do not locate the power cord where it can be walked on or will create a tripping hazard. Connect the 3-wire power plug to only a 3-wire grounded outlet. Never connect 2-wire to 3-wire adapters to the power cord or remove the third ground wire to fit the plug into a 2-wire electrical outlet. Modifying or overriding the third-wire ground creates a safety hazard and should not be permitted.



DANGEROUS VOLTAGE

Always disconnect the power cord from the source of AC power before unplugging it from the QC-300 power connector. The AC voltage available at electrical outlets is extremely dangerous and can cause serious injury or death.

Electrical wiring and connections

Perform regular inspections of all connections to the QC-300. Keep connections clean and tight. Locate cables away from moving objects. Do not create tripping hazards with power cords, input/output cables or other electrical wiring.

Use shielded cables to connect to the serial RS-232 port. Make certain that cables are properly terminated and firmly connected on both ends.

Location and mounting

Rest the QC-300 on a flat, stable surface, or bolt it to a stable surface from the bottom using four 10/32 screws fastened in the pattern shown at the right.

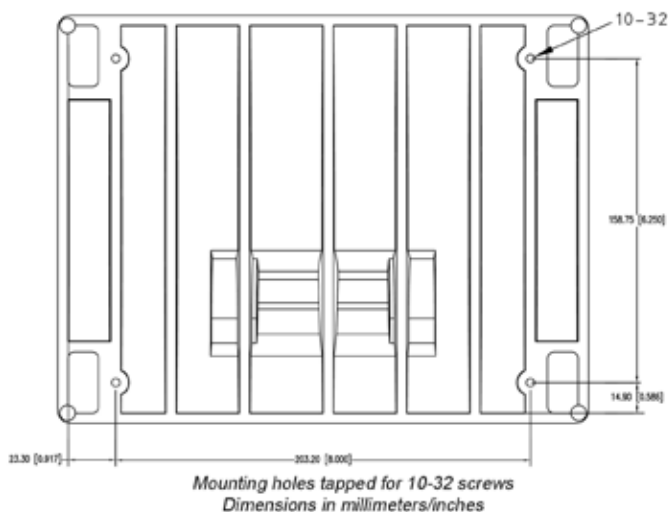

Power surge suppressor

Connect the QC-300 to power through a high-quality power surge suppressor. Surge suppressors limit the amplitude of potentially damaging power line transients caused by electrical machinery or lightning. When a surge suppressor is not used, power line transients can corrupt system memory or damage circuits.

Connecting axis encoders

Axis encoders are attached to interface connectors on the rear of the QC-300. Many encoder interfaces are available to match the wide variety of encoders that can be used with the QC-300. The type of axis encoder connectors will vary depending on the application. Encoder inputs are specified as analog or TTL at the time of purchase and cannot be changed in the field.

- 1 Verify that the QC-300 is off.
- 2 Connect the axis encoders tightly to their connectors. An axis label is provided near each connector. Do not overtighten the connector screws.

**X, Y, Z and Q axis
input connectors**



Encoder input parameters must be configured later using the Encoder setup screen. Please refer to [Chapter 10: Setup](#) for details regarding encoder setup.

Connecting a printer

The QC-300 supports certain USB printers. Printer models must be specified by Metronics when the QC-300 is ordered, or approved by Metronics later.

- 1 Verify that the QC-300 and printer power are off. Connect the USB printer to the USB Type A port on the side of the enclosure.
- 2 Make sure the USB cable plug is fully inserted.



Connecting a computer

- 1 Verify that the QC-300 and computer power are off.
- 2 Connect a computer COM port to the QC-300 RS-232 serial port using a standard straight-through serial cable (Metronics part number 11B12176). Make sure the cable connectors are tight, but do not overtighten the connector screws.
- 3 Apply power to the computer, and then the QC-300. The default QC-300 settings for communication over the RS-232 serial port are shown here.

- Baud rate: 1200
- Parity: None
- Data bits: 7
- Stop bits: 1
- Flow control: Hardware

- 4 Launch the computer application that will be used to communicate with the QC-300, and configure the communication properties of the COM port to match those of the QC-300.

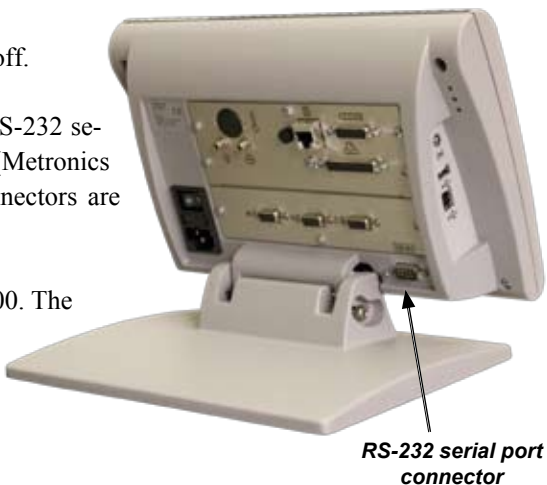

Connecting an optional footswitch

The optional foot switch is connected to the RJ-45 connector on the rear of the QC-300.

- 1 Verify that the QC-300 is off.
- 2 Connect the foot switch to the RJ-45 connector on the rear connector panel.

Footswitch connector

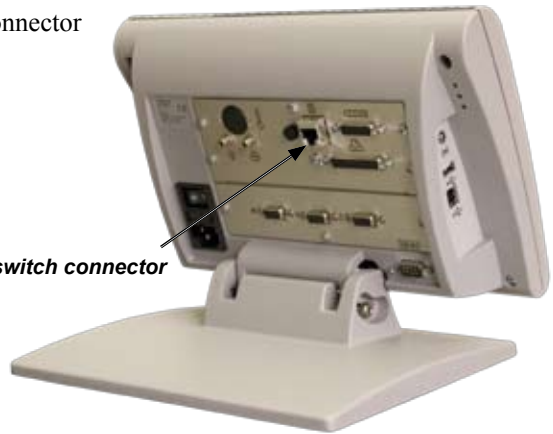

Connecting the optical edge detector inputs

The optional optical inputs are connected to the two optical jacks on the rear of the QC-300.

- 1 Connect fiber-optic cables to the QC-300 and then connect to the comparator. The screen sensor cable connector is marked with a crosshair icon and the reference cable connector is marked with a light bulb icon. Attach all cables securely to the appropriate connections.

- 2 Secure the sensor cable to the comparator screen using the plastic mounting plate provided. Place the mounting plate under the comparator's chart clips so the small hole in the plate is positioned over a lit portion of the comparator screen.

- 3 Clean the collecting end of the sensor cable with a soft lint-free cloth as necessary. Place the metal tip of the sensor cable through the hole in the mounting plate flush against the screen.

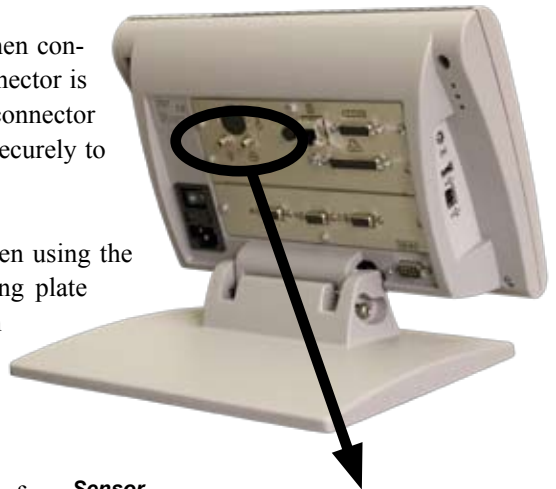

Sensor cable jack

Reference cable jack

Optical jacks

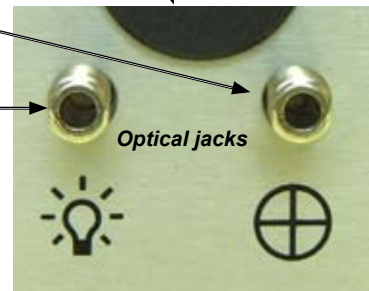

CAUTION

Be careful not to scratch the screen with the metal tip.

- 4 Secure the sensor cable to the plastic mounting plate.
- 5 Point the reference sensor directly at the comparator lamp. Consult the comparator manufacturer's information for specific mounting instructions.

**CAUTION**

Avoid mounting fiber-optic cables next to the lamp. High temperatures degrade fiber-optic cable performance. Install the cable to receive cooling air from the lamp fan if possible.

The optical inputs must be configured later in QC-300 Magnifications setup screen. Please refer to [Chapter 10: Setup](#) for details regarding optical edge detector setup.

Connecting optional CNC outputs

The optional CNC joystick and amplifier outputs are connected at the CNC output connector on the rear of the QC-300.

- 1 Verify that the QC-300 and CNC amplifier are off. Connect the CNC amplifier and joystick to the 26-pin D-sub connector on the rear of the QC-300.
- 2 Make sure the connector is fully inserted and make sure the cable connectors are tight, but do not overtighten the connector screws.

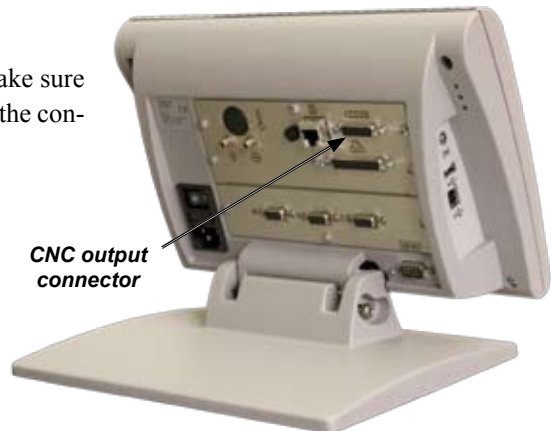

Warranty registration form

The warranty registration form included in the shipping carton should be completed and mailed as soon as possible. Also record the purchase and warranty information here so that it will be readily available later to support any necessary interactions with distributor or factory technical support personnel.

QC-300 model number	QC-300 serial number
Purchased from	Date received
Software version number	

The software version can be found in the Hardware setup screen. Refer to [Chapter 10: Setup](#) for screen descriptions.

Repackaging for shipment

Repackage the QC-300 in the original packaging as received from the factory, or equivalent. It is not necessary to ship the base when shipping the QC-300 for repair.



CAUTION

The original packaging must be duplicated and the LCD must be inserted face-up to prevent damage to the LCD screen.

Pay special attention to the following instructions:

- 1 Connect any loose mounting hardware to the QC-300 instrument
- 2 Repackage the foam and cardboard carton inserts as originally shipped from the factory.
- 3 Place the QC-300 into shipping carton with the LCD facing up.
- 4 Replace the warranty card and slip sheets found at the top of the carton. The “Before you begin” slip sheet should be inserted last.

What's next?

Proceed to [Chapter 10: Setup](#) to configure your QC-300 for use. Follow the instructions for *Essential Setup* as a minimum.

Chapter 3: User Interface

The QC-300 user interface consists of hardware front panel buttons and number keys that work in cooperation with software menus, buttons, and data fields shown on the color LCD touch screen. The hardware/software interface is divided into the function areas listed and shown below.

- Measurement functions
- Command buttons and wide keys
- Feature list
- Screen functions
- LCD ON/OFF or delete features
- Number keys
- System functions
- Printing reports and sending data



Measurement functions

The measurement functions are divided into two tabbed areas:

- Measure Select a measurement type, such as circle or line
- Program Record, edit or play back a program of measurement steps

Selecting a measurement type

Measurement types are selected from the Measure tab. Touch the Measure tab to display icons for the different measure types.

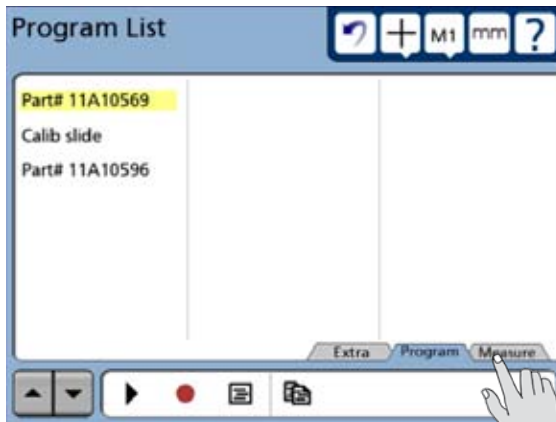

Touch the Measure tab...

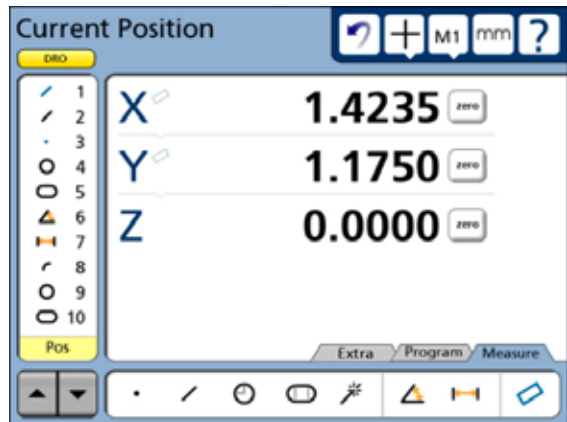

to display measure types

Touch a measure icon to select the desired measure type. In some cases, such as when selecting circles and slots, related measure types will also be presented as shown in this example of touching the circle icon to display the arc measure type.



Touching the circle measure icon...

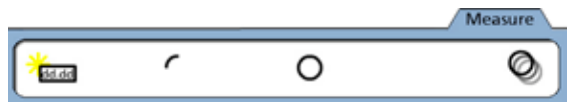

also provides access to the arc measure type



NOTE

Details regarding performing measurements and the use of measurement tools are provided in [Chapter 6: Measuring](#).

Accessing programming functions

Programming functions are accessed from the Program tab. Touch the Program tab to display a list of programs and programming tools. Details regarding programming and the use of programming tools are provided in [Chapter 8: Programming](#).

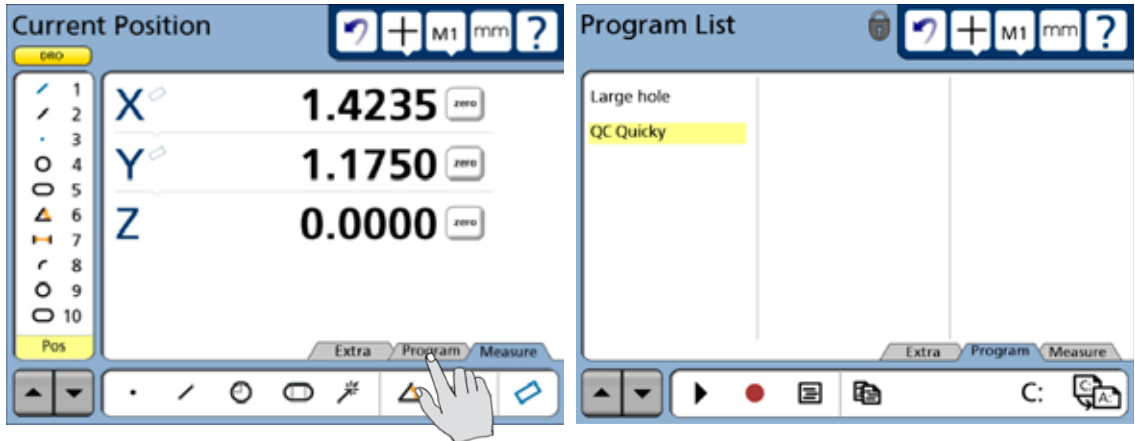

Touch the Program tab...

to display a list of programs and programming tools

Touch a program tool icon to play, record, edit, copy, stop or add a user message to a measurement program. In the Edit mode, completed program steps are shown in the feature list.



Programming tools shown before recording



Programming tools shown during recording

- Run a program
- Record a program
- Open edit mode
- Copy a program
- Select a drive
- Copy to drive

- Run a program
- Stop recording
- Open edit mode
- Include user message
- Goto here: Used to define locations for CNC program moves

Additional CNC functions that can be included in programs are contained in the Extra tab shown later in this chapter, in [Chapter 6: Programming](#) and in [Chapter 10: Setup](#).

Sending data to a computer from the Extra tab

Touch a data icon shown in the Extra tab to send the corresponding data element for the current position or selected feature to a computer over the serial port. Touch the Extra tab to display the data choices.

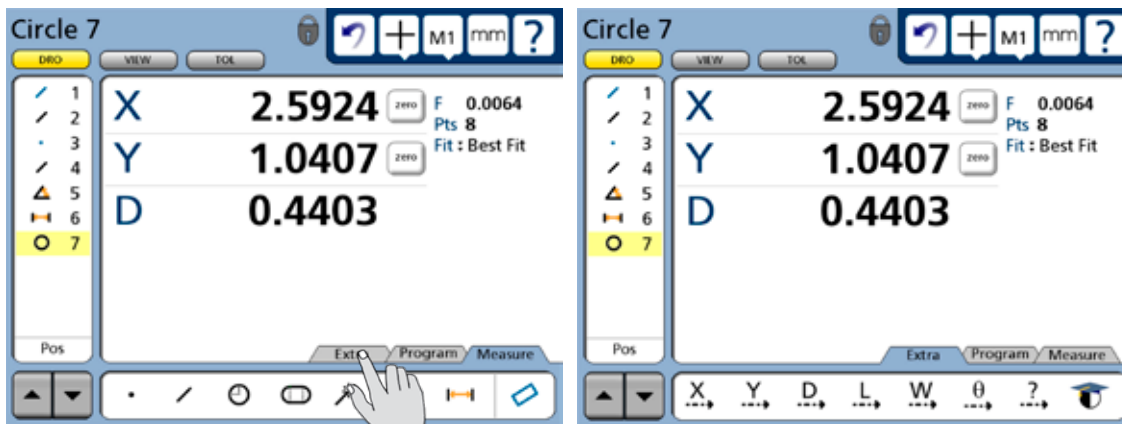

Touch the Extra tab...

to display the data choice icons



NOTE

The Extra tab is configured in the Display setup screen. Please refer to [Chapter 10: Setup](#) for details.

The data sent to the serial port always corresponds to the information displayed in the DRO screen. The information types are shown in the upper-left corner of the screen and are:

- Current position (no feature selected)
- Feature measurement (feature selected)



NOTE

Touching an icon for an inappropriate data type produces no result. For example, touching the diameter icon when a circle feature is selected in the feature list sends diameter data to the serial port, however, touching the angle icon when a circle is selected produces no result.

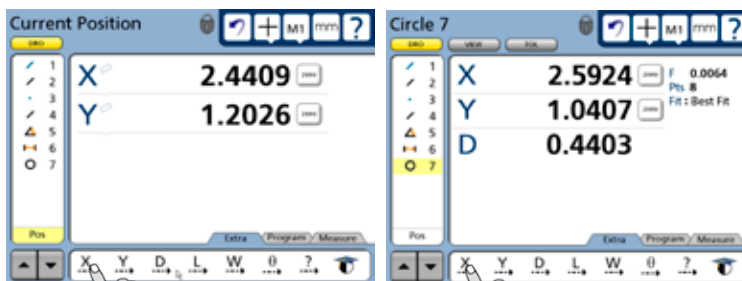

Send current position data...

or send feature measurement data

The Extra tab is typically used to send abbreviated data to the serial port since complete reports or screens of data can be sent using the Print function described in [Chapter 10: Setup](#). However, a complete data set can be sent for a feature from the Extra tab by touching the required series of icons in succession.

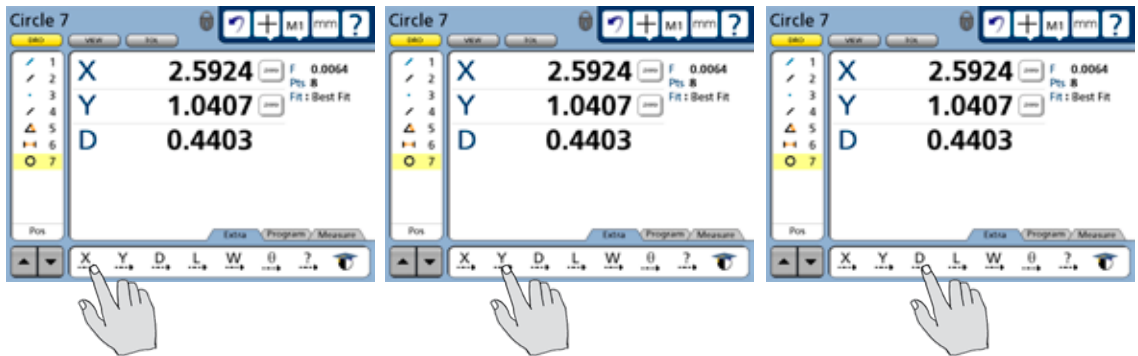

A complete data set for the selected circle is sent to a computer by touching each data icon in succession

The transmission of data to the serial port from the Extra tab can be included in programs, like any other measurement, tolerancing or reporting activity.

CNC and other Extra tab functions

Additional CNC functions for programming, motion control, edge probe calibration and Extra tab formatting functions can also be made available in the Extra tab as described in [Chapter 10: Setup](#), in the Display screen section.

Extra tab functions

Space menu insert



The space insert are included in the Extra tab to separate control functions into groups on the tab.



Extra tab divided by space into data and CNC groups

Divider line menu insert



The divider line insert are included in the Extra tab to separate control functions into groups on the tab without using a space insert.



Extra tab divided by line into data and CNC groups

Data prompt function



The data prompt function is included in the Extra tab to send a user-defined measurement such as X position, Y position, radius or angle to the serial port, USB printer or USB drive as a file. When the user touches the data prompt function, a prompt message is displayed and the user selects the desired piece of measurement data to be transmitted.

Optical edge detector probe calibration (probe teach)



Teaching the edge detector calibrates it to correctly recognize dark to light transitions (edges) on the comparator screen. A teach calibration should be performed after each startup, whenever the part or magnification level changes or when the light conditions on the comparator change. Edge calibration is described in detail in [Chapter 5: Probes](#) and [Chapter 10: Setup](#).

Joystick motor speed



The Joystick motor speed function is included in the Extra tab of systems with the CNC option to adjust the joystick control of motor speed. When the user touches the Joystick motor speed function, the joystick control of motor speed is toggled between fast and slow.



Fast



Slow

Axis lock



The Axis lock function is included in the Extra tab of systems with the CNC option to restrict stage motion to only one axis. When axis lock is on, motion is permitted only along one axis; diagonal motion is not permitted. When the user touches the Axis lock function, axis lock is toggled on or off.



Axis lock
on



Axis lock
off

Part following



The Part following function is included in the Extra tab of systems with the CNC option. Part following changes the motion reference from the machine coordinate system to the part coordinate system after a part skew has been performed. For example, if a skew is performed along the part's X-axis, when part following is enabled, subsequent X-axis motion will follow the part skew, not the machine coordinate's X-axis. When the user touches the Part following function, part following is toggled on or off.



Stop motion



The Stop motion function is included in the Extra tab of systems with the CNC option to stop all stage motion. When the user touches the Stop motion function, motion is toggled on or off.

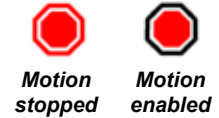

Goto feature



The Goto feature function is included in the Extra tab of systems with the CNC option. When the user touches the Goto function, the stage is moved to position the probe over the feature currently selected in the feature list.

Multiple Extra tabs

Multiple Extra tabs might be necessary to display all the Extra tab functions available. Touch the Extra tab repeatedly to access multiple tabs.

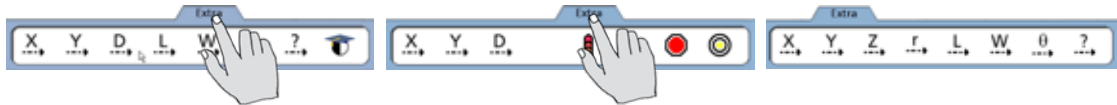

Touch the Extra tab repeatedly to cycle through available tabs

Command buttons and wide keys

The command buttons and wide keys are primarily used to support measurement and setup activities. The command wide keys are duplicates of the Enter and Finish functions which are the most frequently used command buttons, and can be located and pressed easily by the operator without looking at the front panel.

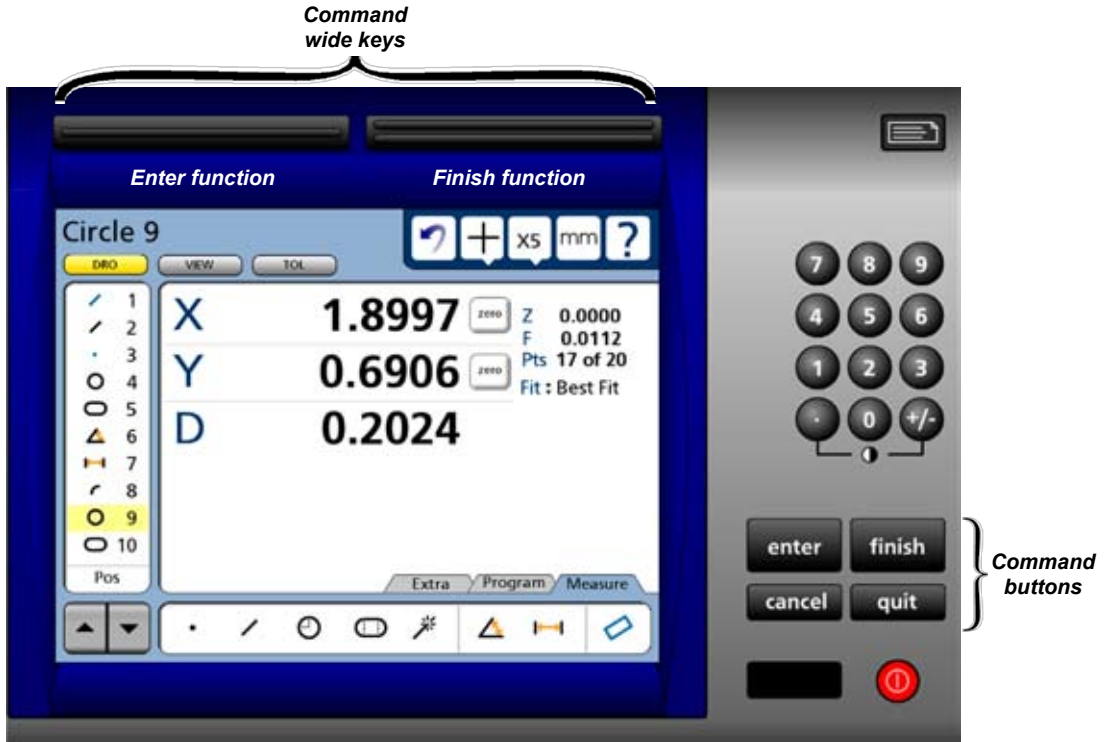

- Enter Enters a point (or points) into a measurement, or enters a value into a measurement data field, tolerance data field, communication data field or a setup data field
- Finish Completes a measurement, tolerancing or setup session
- Cancel Removes the last point from a measurement, deletes a feature from the feature list, or removes the last character from a data field
- Quit Cancels a measurement in progress, ends a setup session without saving new settings and ends a programming session



NOTE

Details regarding the use of the command keys are provided in **Chapter 6: Measuring**, and are distributed throughout the remainder of this user guide.

Feature list

The feature list provides access to all features that have been measured, constructed or created. Measurements are selected by touching them in the feature list, and then viewed or toleranced in other screens.

Feature list

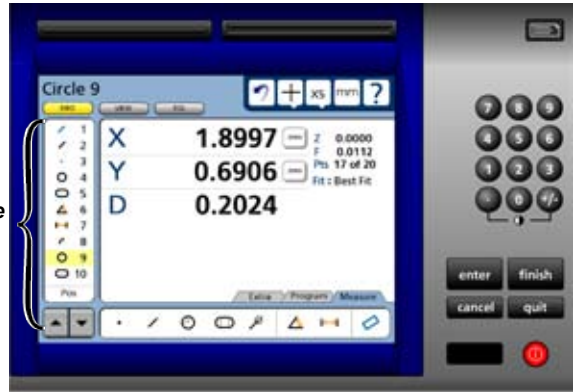

When the feature list contains too many entries to be displayed simultaneously, the arrow keys at the bottom of the list are used to scroll up or down to display all the entries.

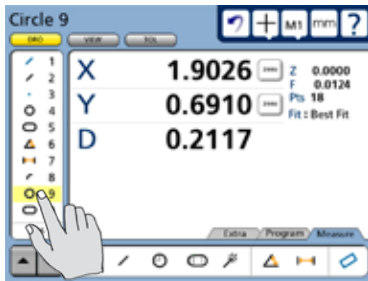

Selected measurements can be...

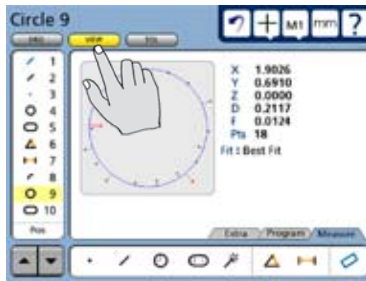

viewed...

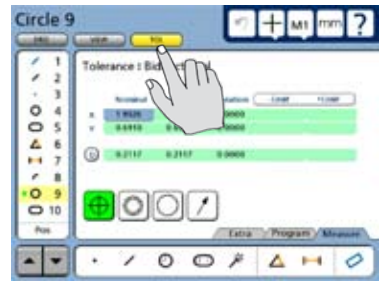

or toleranced in other screens

When recording, playing or editing programs, the program steps are shown in the feature list.



NOTE

Details regarding the use of the feature list are distributed throughout the remainder of this user guide.

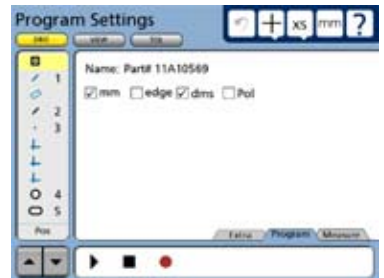

LCD Screen functions

The LCD functions are used to select the screen that will be presented on the color touch LCD, generally in support of the next operator activity

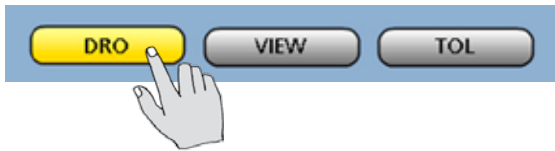

Touch a button to select the desired screen.

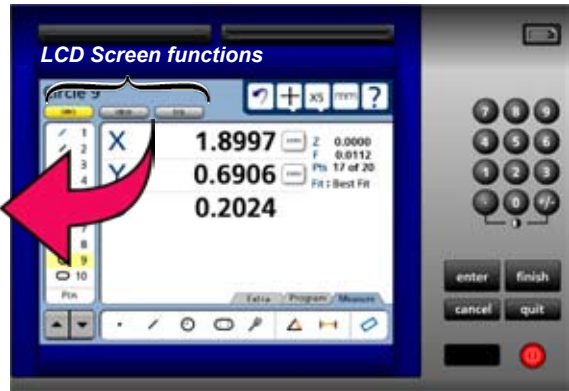

- DRO Displays the digital readout
- VIEW Displays the selected feature's data cloud
- TOL Displays the tolerance screens for entering and editing tolerances

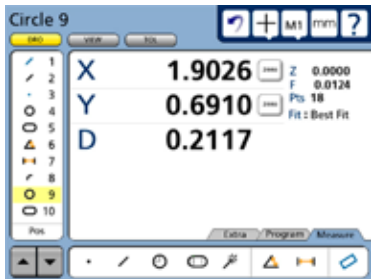

DRO screen

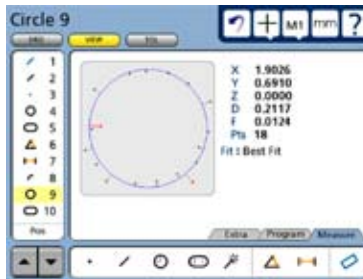

View screen

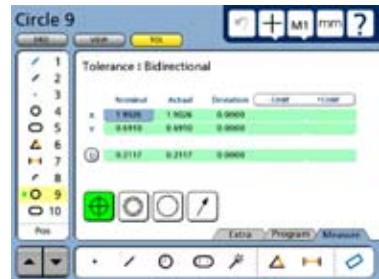

Tol screen



NOTE

Details regarding the use of the three basic screen types are distributed throughout the remainder of this user guide.

Number keys

The number keys are used to enter data into feature constructions and creations, tolerances, programs, and setup data fields.

Numbers are entered into data fields in the conventional manner, and can be erased when necessary by backspacing over them using the Cancel button.



NOTE

Details regarding the use of number keys are distributed throughout the remainder of this user guide.

System functions

System functions support a wide variety of measurement and setup activities. System functions include:

- Datum lock
- Undo
- Probe
- Magnification (Mx)
- Unit of measure (mm/Inch)
- Setup

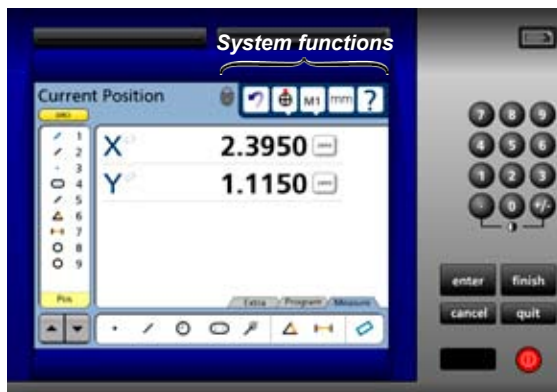

Datum lock



The lock icon indicates that features are locked to the datums used when they were measured. When the lock icon is not shown, new datums are applied to all features in the feature list as they are created. Datums are locked and unlocked in the Measure setup screen.

Undo



The Undo function is very similar to the Windows undo function and erases the last measurement or feature list activity step. The Undo function only erases the last step, sequences of steps cannot be erased using undo.

Probe



The Probe function provides access to the available measurement probe types. Touching the Probe button shows the drop-down list of available probes. Probe types can include crosshair and (optional) optical edge detector probes:

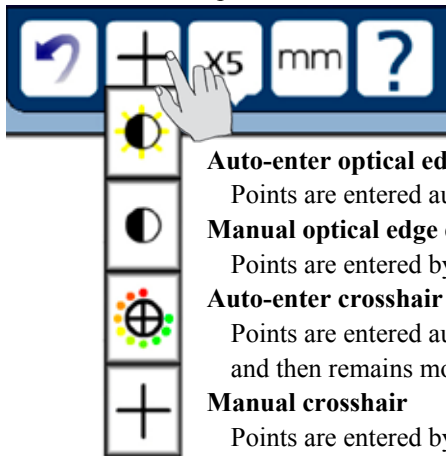

Auto-enter optical edge detection

Points are entered automatically when edges are crossed

Manual optical edge detection

Points are entered by pressing the Enter key after edges are crossed

Auto-enter crosshair

Points are entered automatically when the stage is moved to a new position and then remains motionless for a short time

Manual crosshair

Points are entered by pressing the Enter key after positioning the crosshair

Touch the desired probe type to select it.

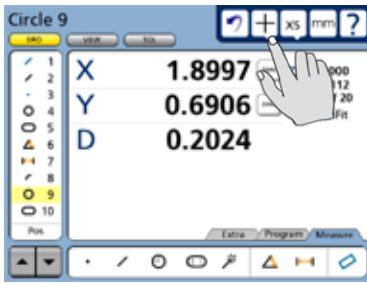

Touch the Probe button...

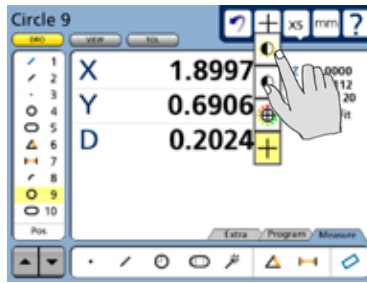

to select a probe type...

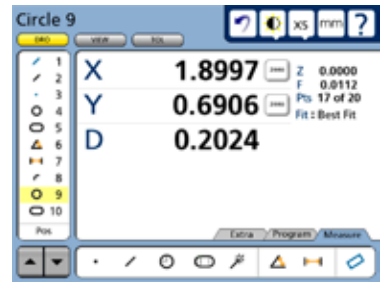

from the drop-down list

Magnification



The Magnification function provides access to a drop down list of available measurement magnifications. Touching the Magnification button shows the list of available magnifications. Touch the desired magnification to select it.

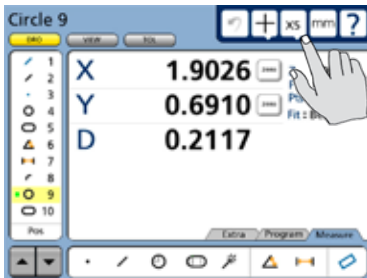

Touch the Magnification button...

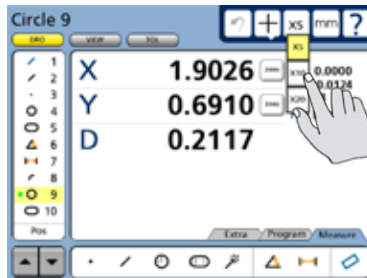

to select a magnification...

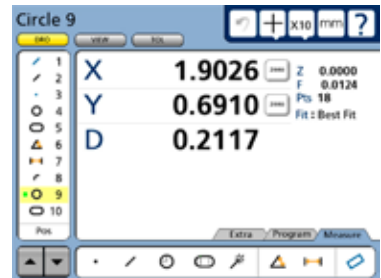

from the drop-down list

Unit of measure



The Unit of measure function toggles the linear unit of measure between metric and English. Touch the mm/in button to toggle the units of measure.

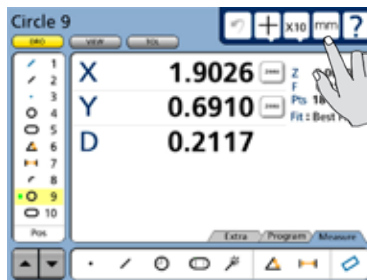

Touch the mm/in button...

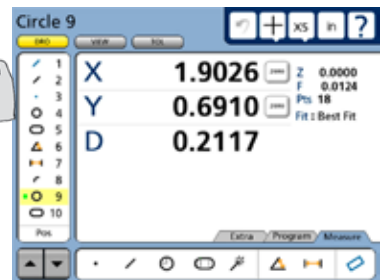

to change the linear unit of measure

Setup



The setup function provides access to all of the system setup screens required for configuring QC-300 measurement and operation. Touch the setup button to display the setup screen and menu. Access to the setup menu is given through two introductory screens that show the software version, the system options and a caution regarding the use of setup functions.

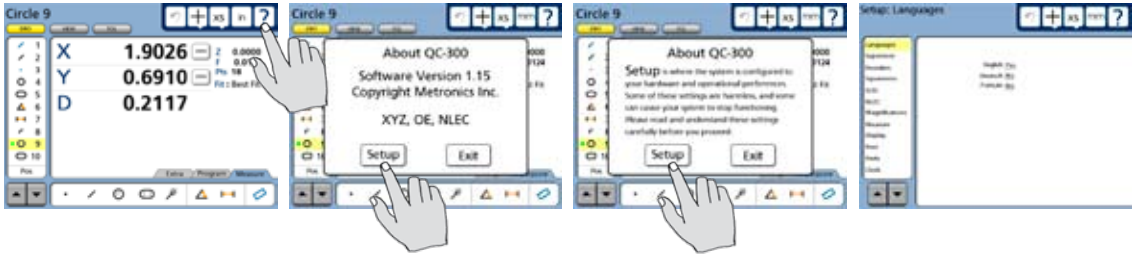

Setup screen tools will be made available to those who can provide a valid supervisor password.

**NOTE**

Detailed descriptions of all setup functions and tools are contained in **Chapter 10: Setup.**

Printing reports and sending data

Measurement data shown on the DRO screen or contained in the feature list can be printed in reports over the USB port or sent to a computer over the RS232 serial port. In either case, the printing of reports and the transmission of measurement data is initiated by pressing the Print button.

**NOTE**

Report printing and data transmission are configured in the Print setup screen described in **Chapter 10: Setup.** Printing and data transmission are described in **Chapter 9: Communication.**



LCD ON/OFF and deleting feature data

The LCD screen can be turned off without cycling power when the QC-300 will not be used for an extended period, but it is desirable to retain the original machine zero encoder references. Press the red LCD ON/OFF button to toggle the LCD on and off.

When the LCD ON/OFF button is pressed, the operator is given an opportunity to erase all feature measurement data and resume operation without turning the LCD off. If the operator presses the Enter key to delete feature data, the system will ask for confirmation. If confirmation is given, the feature data and datums will be permanently deleted.

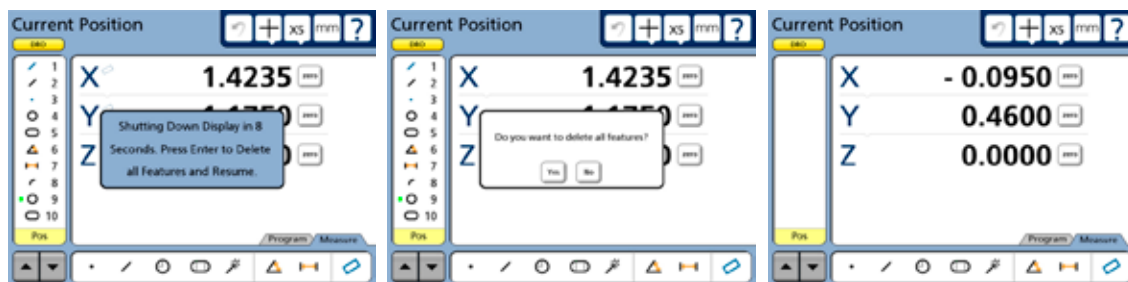

You will be asked to press Enter... and asked to confirm the delete... then the feature data will be deleted



CAUTION

Delete feature data only when you have saved the data in a report, transmitted it to a computer file or are sure that you no longer need them. Once the data are deleted, they cannot be restored.

Chapter 4: Quick Start Demonstration

This chapter demonstrates the operation of the QC-300 system. The demonstration is provided as a means of quickly helping experienced operators to use the system. This demonstration will be most helpful if you perform the measurements and other activities as you follow along.

The demonstration will use the Metronics QC Quickie slide to create a part skew and datum, measure a part feature, apply a few tolerances, print a tolerance report and save all these activities as a program that can be recalled and run again later.



The QC Quickie slide is shipped with each system

When the program is run on a manual system, the series of required points will be indicated by a green arrow that moves over the part outline in the Part View window. The user need only probe locations indicated by the arrow to complete measurements.

The demonstration will show measurements being performed on a manual stage using a manual crosshair probe. However, the same measurements could also be performed using optional optical edge detection.

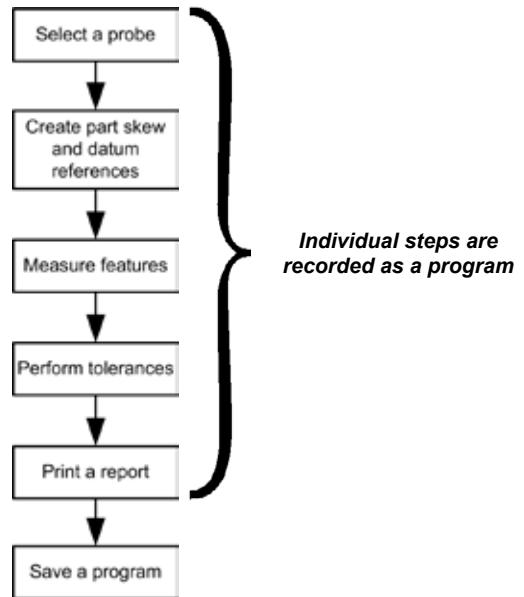

Summary of the Quick Start Demonstration

Detailed information regarding datuming and measuring is contained in [Chapter 6: Measuring](#). Information regarding tolerancing is contained in [Chapter 7: Tolerancing](#). Report printing is discussed in [Chapter 9: Communication](#). Information regarding programming is contained in [Chapter 8: Programming](#).

Start recording a program

To record the following activities as a program:

1 Touch the Program tab to display the program screen and then touch the Record icon. The text entry screen will be displayed.

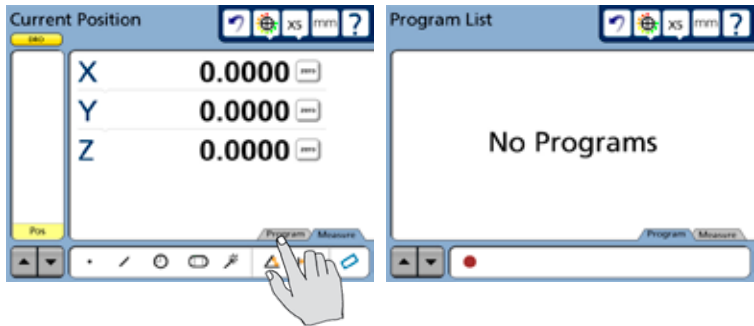

2 Enter a program title and press the Finish key. The DRO will be displayed. The measure icons will also be displayed and the Program tab will be shown in red to indicate that programming is in progress.

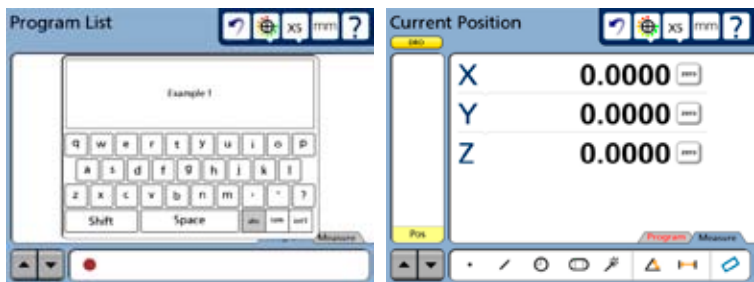

Select a probe

To select a new probe:

1 Select a new probe type by touching the Probe button. The probe choices will be shown in the probe drop-down list.

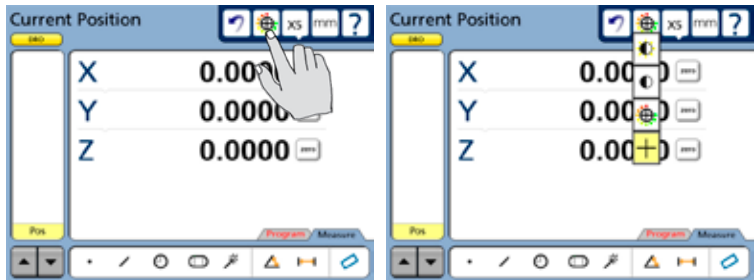

2 Touch the desired probe button. The probe drop-down list will close and the new probe button will be displayed. In this example the straight crosshair probe is selected.

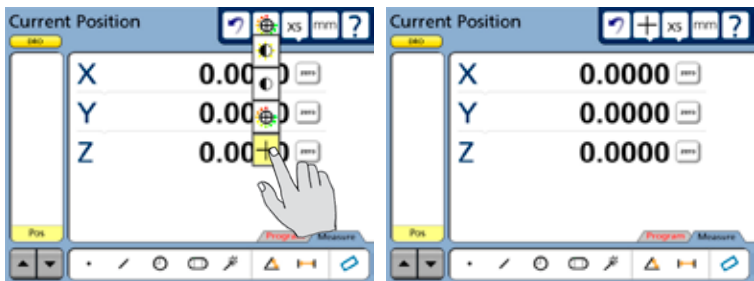

NOTE

More information regarding preparing and using probes is contained in [Chapter 5: Probes](#).

Create part skew and datum references

When the part is misaligned (twisted) in the X-Y plane, errors can be generated during the measurement process. These errors can be eliminated by creating a skew alignment for the part.

The skew alignment includes a precise measurement of the part misalignment. Once the misalignment is known to the system, subsequent feature measurements are automatically compensated to eliminate misalignment errors. Measurement data in the DRO will reflect measurements of a perfectly aligned part.

Measuring a part skew

To skew the part:

- 1 Touch the Skew/Level Measure icon.

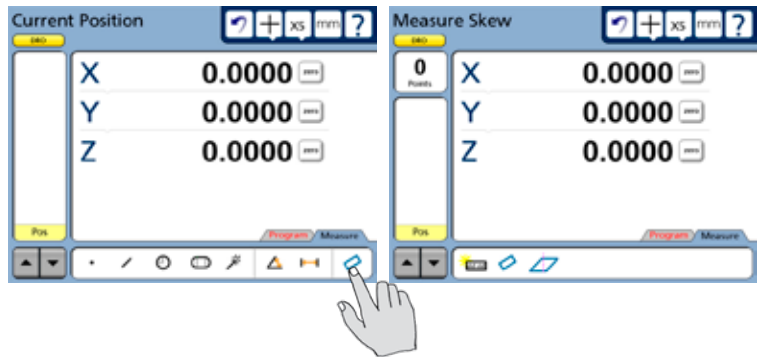

- 2 Perform the skew alignment by probing 2 or more points well distributed along the entire length of the desired part reference edge. Press the Enter key to enter each point. Press the Finish key to complete the Skew measurement. The skew line feature will be added to the Features list in blue.

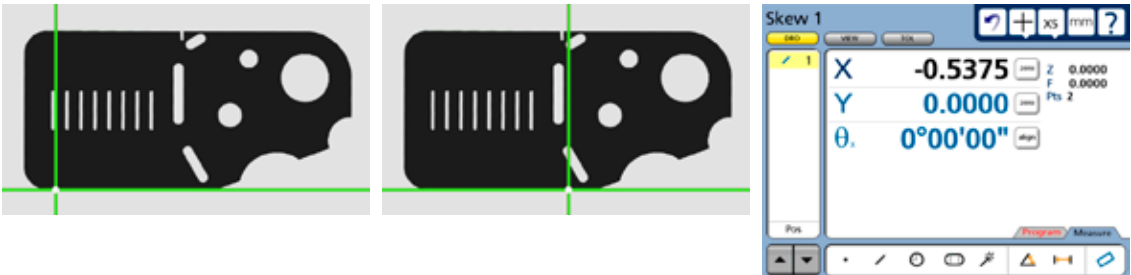

Create a datum zero point

Creating the datum zero point is the final step in establishing a valid Cartesian or polar coordinate system for subsequent measurements. The datum zero point will be used as the origin of the measurement system. The datum zero point can be positioned in any location that satisfies the measurement requirements of the user and can be created by probing a point or by constructing a point from parent features.

Probing a datum zero point

The datum zero point can sometimes be created directly by probing a point. Simple probing is often possible when the part is precisely aligned in the stage.

To probe a datum zero point:

- 1 Touch the measure point icon. Probe the desired point for the datum zero, and then press the Finish key. In this example, the lower left corner of the QC Quicky slide is probed. The point will be added to the Feature list.

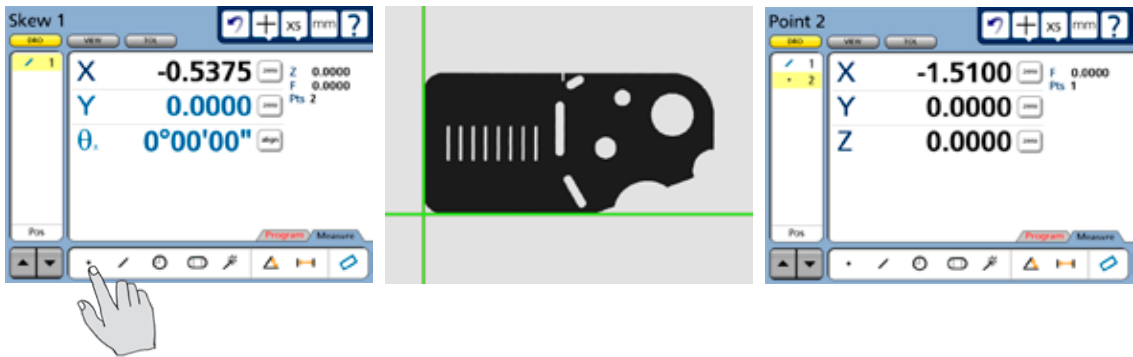

- 2 While the point feature is selected, touch the X and Y axis Zero buttons to zero the values and establish a datum zero at the probed point. The point will then be shown in blue in the feature list.

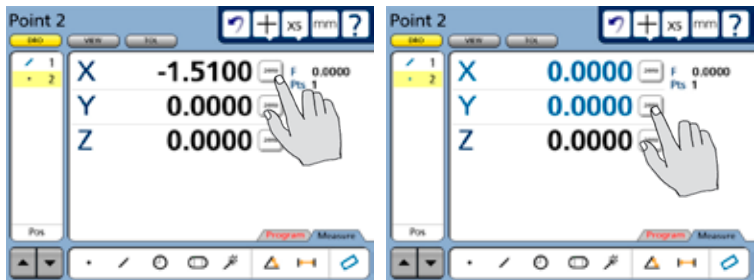

Constructing a datum zero point

The datum zero point can be constructed from parent features when simply probing the desired point is not practical.

It would not be possible to provide a single description of this process for all measurement applications that require feature constructions. However, the concept illustrated by the following example and the construction techniques described later in [Chapter 6: Measuring](#) can be used to construct a datum zero point for any measurement application.

In this example, after the part skew is performed, a datum zero point is created at the intersection of the X-axis along the bottom of the part (skew axis), and the Y-axis along the left side of the part.

To construct the datum zero point:

- 1 Touch the Measure Line icon. Probe two or more points well distributed along the left side of the part, and then press the Finish button. The line feature will be added to the Feature list

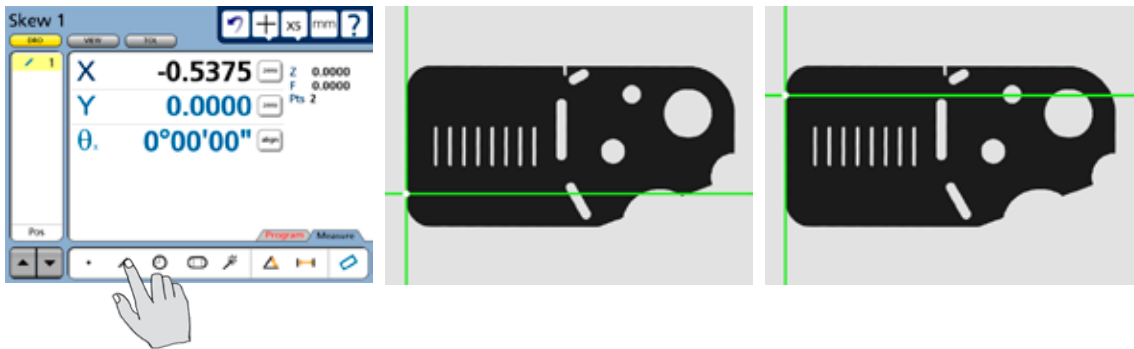

- 3 Touch the Measure Point icon, touch the skew line, touch the line probed on the left side of the part (the lines will be checked) and then press the Enter key. A point constructed at the intersection of the two lines will be added to the Features list.

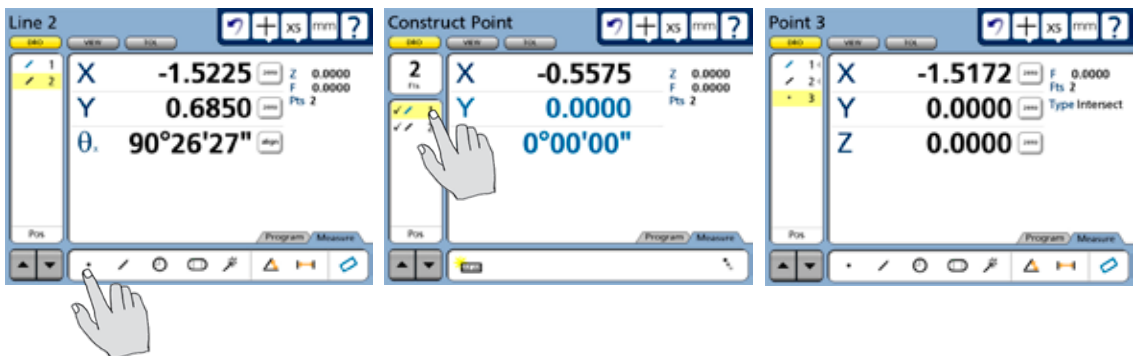

4 While the point feature is selected touch the X and Y axis Zero buttons to zero the values and establish a datum zero at the probed point. The point will then be shown in blue in the feature list.

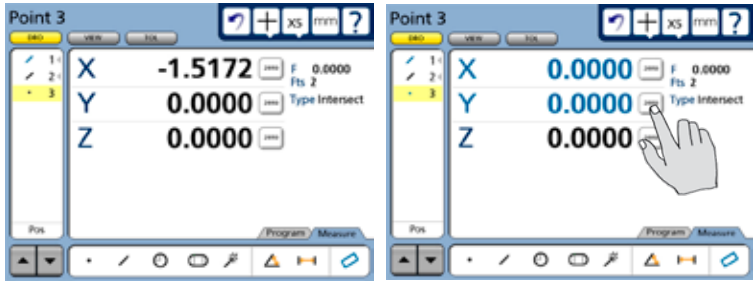

NOTE
More information regarding creating datums and constructions is contained in **Chapter 6: Measuring.**

Measure a feature

In this example, the largest of the three holes of the QC Quickie slide will be measured using the crosshair probe.



NOTES

More information regarding feature measurements and constructions is contained in [Chapter 6: Measuring](#). More information regarding the use of crosshair or optional edge detection probes is contained in [Chapter 5: Probes](#).

Measuring a circle

To measure a circle using crosshairs:

- 1 Select the manual crosshair probe.

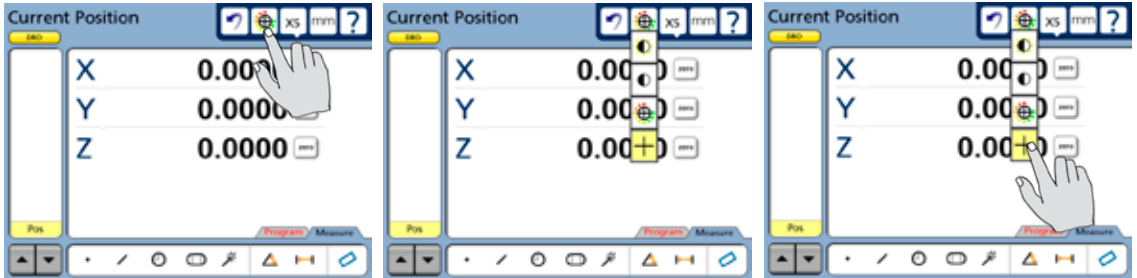

- 2 Touch the measure circle icon and probe a minimum of three points evenly distributed around the perimeter of the circle. Four points were probed in this example.

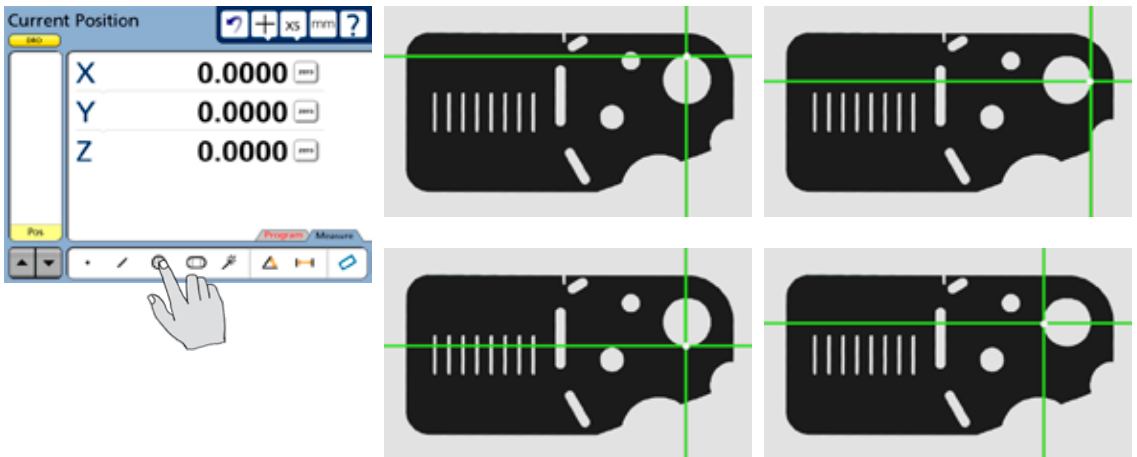

3 Press the Finish key to complete the feature measurement and store the feature in the feature list. The feature and probed points can be reviewed in detail by touching the View button if desired.

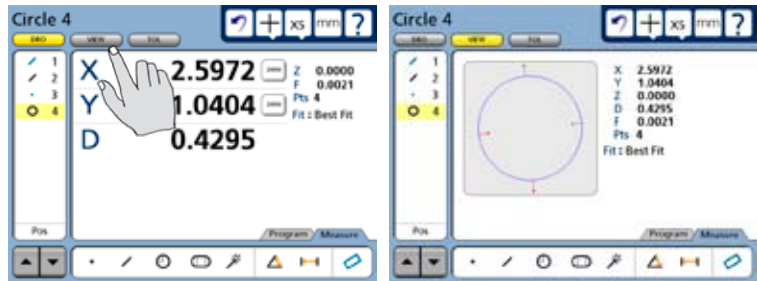

Apply tolerances to a feature measurement

In this example, a true position tolerance will be applied to the circle measurement. To apply a tolerance:

1 With the circle feature selected, touch the Tol screen button to display the tolerance screen.

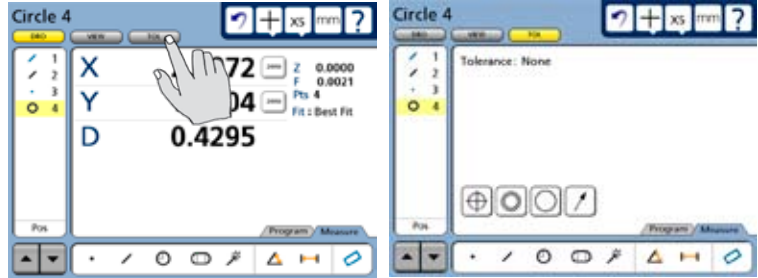

2 Touch the desired tolerance type icon button to select a tolerance type. In this example, the position tolerance type is selected.

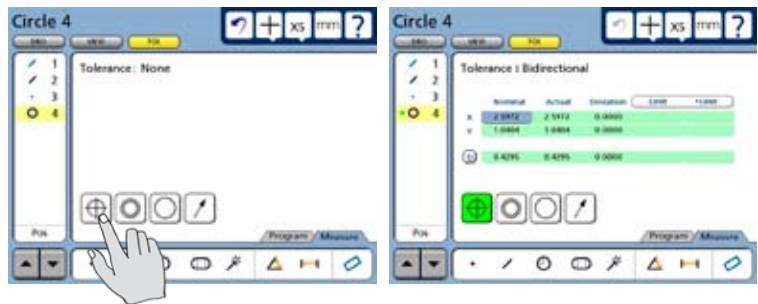

4 Select a specific position tolerance. Touch the Tolerance menu title and then select the specific tolerance from the drop-down menu. The true position tolerance is selected in this example.

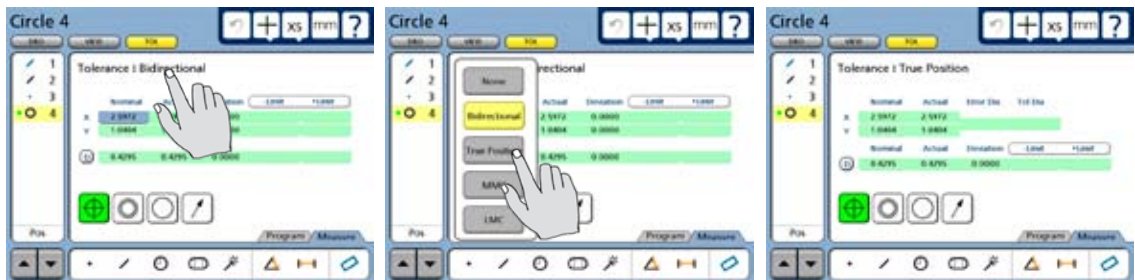

5 Enter nominal, limit or tolerance values. In this example, the Nominal and Tol Dia (Tolerance diameter around the nominal position) values are entered by touching the desired data fields and entering new values using the number keys. Error and Deviation values are generated as soon as the Nominal and Tol Dia values are entered.

	Nominal	Actual	Error Dia	Tol Dia
X	2.5972	2.5972		
Y	1.0404	1.0404		

(D)	Nominal	Actual	Deviation	-Limit	+Limit
	0.4295	0.4295	0.0000		

When Nominal, limit and Tol Dia values are entered...

	Nominal	Actual	Error Dia	Tol Dia
X	2.6000	2.5972	0.0108	0.0500
Y	1.0450	1.0404		

(D)	Nominal	Actual	Deviation	-Limit	+Limit
	0.4300	0.4295	-0.0005	0.0010	0.0010

new error and deviation values are shown

Pass/fail results are indicated by green and red colors in the tolerance screen and in the feature list. Pass is indicated by green, fail is indicated by red in the tolerance screen. Any tolerance failure will be indicated by a red mark next to the feature in the feature list. A green mark will be displayed in the feature list when all tolerance tests pass.

Pass indication is a green square

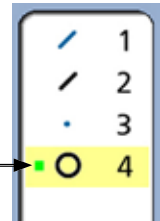

NOTE

More information regarding tolerances is contained in Chapter 7: Tolerancing.

Print a report

To print a report of the current position (Display), the feature list (Report) or tolerances (Tol Report):

- 1 Verify that the QC-300 is attached to a USB printer as described in [Chapter 9: Communication](#).
- 2 Verify that the report content and printer formatting are specified correctly in the Print setup screen described in [Chapter 9: Communication](#) and [Chapter 10: Setup](#).
- 3 Press the Print key while displaying the Current Position in the Video or DRO screen.

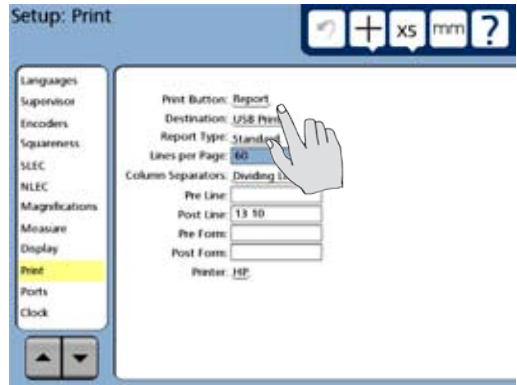

NOTE

More information regarding reports of feature measurement data and QC-300 system settings are contained in [Chapter 9: Communication](#) and [Chapter 10: Setup](#).

Stop program recording

To end a recording session:

- 1 Touch the Program tab to display the programming tools, and then touch the Stop icon to stop recording the program. The program title will be shown on the left side of the screen.

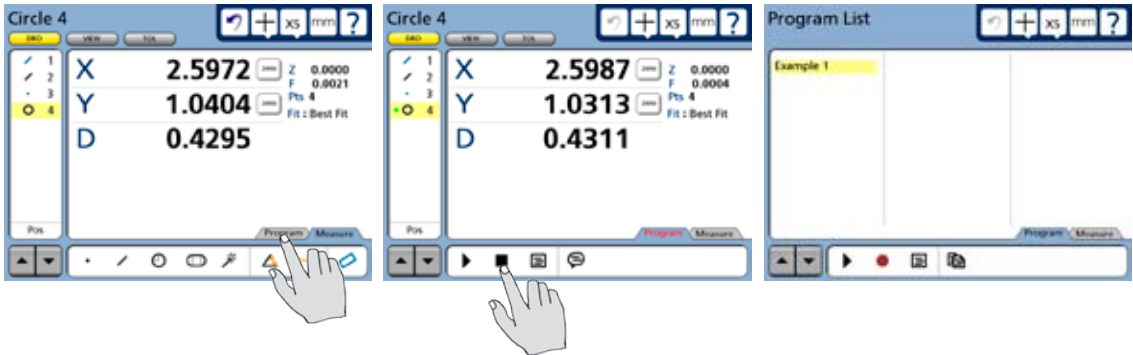

The program is now saved and can be edited or run on new parts.

- 2 Touch the Edit icon button to review or modify program steps. The list of steps will be shown in the feature list. Select a step to review its contents.

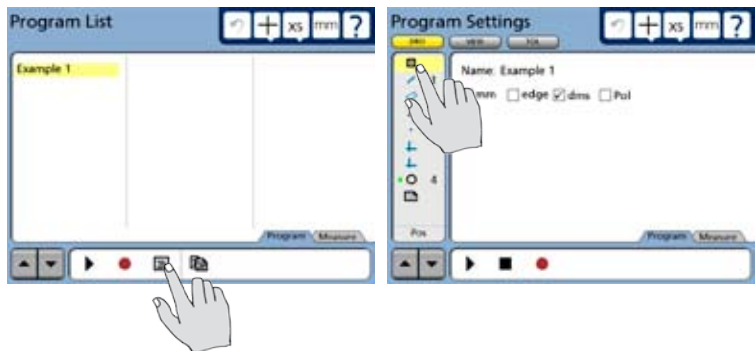

- 3 Touch the Stop icon button and then the Measure tab to leave the record mode and return to the measure mode of operation.

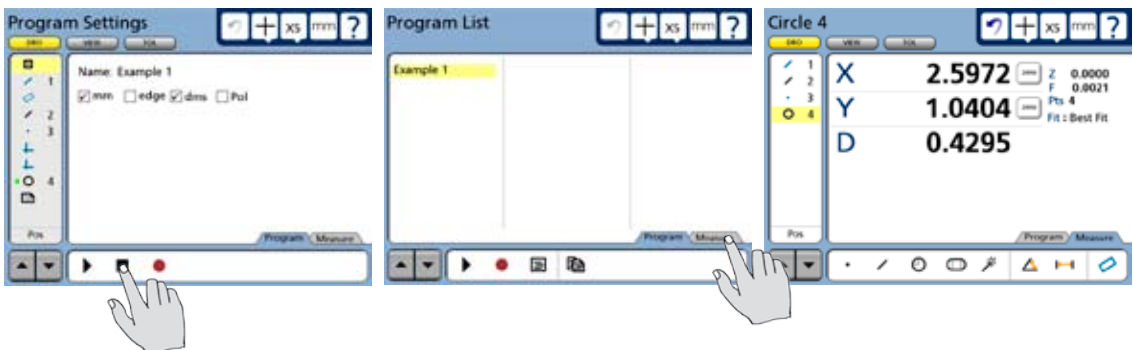

Running the program

To run a program, touch the Program tab to display the program screen, select the desired program and then touch the Run icon to run the selected program.

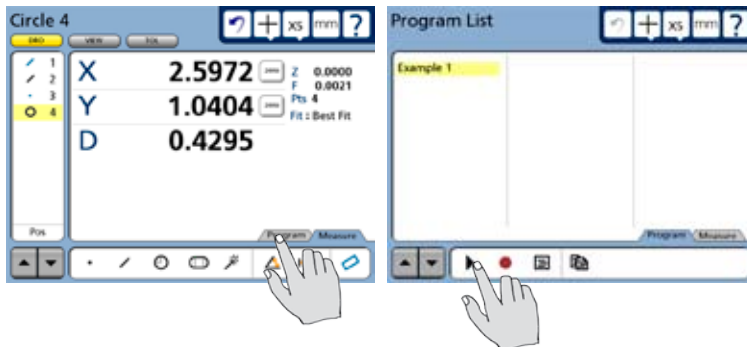

Chapter 5:

Probes

Measurements are conducted using crosshairs or (optional) optical edge detection. In either case, point entry can be manual or automatic. In addition, part probing can be entirely manual or assisted by programs that are prepared by the user.

Crosshair and edge detection probes are described in this chapter. Edge detector setup and calibration is also described in this chapter with references to material in [Chapter 10: Setup](#). The measurement, construction and creation of features is explained in [Chapter 6: Measuring](#).

Probe descriptions	44
Edge detector probes.....	44
Crosshair probes.....	44
Preparing to use probes	46
System and part condition.....	46
Selecting a magnification.....	46
Lighting.....	46
Calibration.....	47
Edge detector calibrations.....	47
Edge teach	47
Distance cal	47
Cross cal	47
Probing with edge detector probes.....	48
Automatic point entry	48
Manual point entry	49
Probing with crosshair probes.....	50
Automatic point entry	50
Manual point entry	50

Probes

Edge detector and crosshair probes can be used to collect data points for feature measurements. Both probe types include manual and automatic point entry functions. Touch the Probe button icon to select a probe.

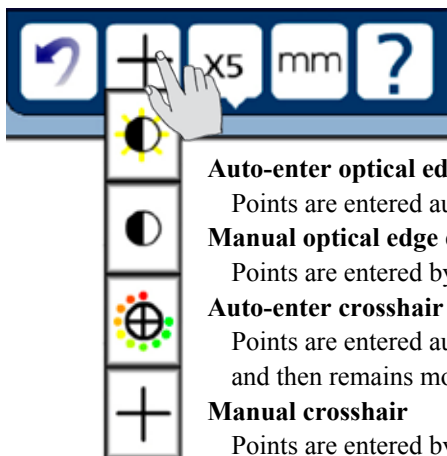

Auto-enter optical edge detection

Points are entered automatically when edges are crossed

Manual optical edge detection

Points are entered by pressing the Enter key after edges are crossed

Auto-enter crosshair

Points are entered automatically when the stage is moved to a new position and then remains motionless for a short time

Manual crosshair

Points are entered by pressing the Enter key after positioning the crosshair

Edge detector probes

Optical edge detection recognizes light to dark and dark to light edge transitions on projector-based systems. Each edge transition is recognized as a point by the QC-300. Edge detection point entry can be automatic or manual.

Automatic point entry



When automatic point entry is used to measure features, a point is entered when an edge is crossed. It is not necessary to press the Enter key to enter the point.

Manual point entry



When manual point entry is used to measure features, a point is stored in a temporary memory location when the edge is crossed. This point is replaced with a new point each time a new edge is crossed. The most recent point is entered as part of a measurement when the Enter key is pressed.

Crosshair probes

Crosshair probes must be positioned precisely over part features to collect feature data points. Crosshair point entry can be automatic or manual.

Automatic point entry



When automatic point entry is used to measure features, the point is entered each time the stage is moved to position the part under the crosshair. The automatic point entry is delayed until the stage has been motionless for a short time after the move to ensure that the crosshair is located where the user intended.



NOTE

The Crosshair Timeout delay is specified in the Measure setup screen. Refer to [Chapter 10: Setup](#) for details.

The crosshair Timeout delay is shown on the DRO as an animated dot revolving clockwise around the probe icon button.



The delay is restarted before the point is entered if the stage is moved again before the delay period is over.



NOTE

The amount of stage movement must be equal to or greater than the Crosshair Distance specified in the Measure setup screen.

Manual point entry



When the manual point entry crosshair is used to measure features, the probe is positioned over the desired Part feature and then the Enter key is pressed.

Preparing to use probes

The accuracy and repeatability of measurements depend on the mechanical condition of the system, the condition of the part, system optics, lighting and calibration.

System and part condition

The measuring system is presumed to be undamaged and well maintained, which implies a recent calibration, and a clean stage with acceptably small amounts of mechanical backlash. The part is also presumed to be clean and properly mounted.

Selecting a magnification

Touch the Magnification button to display a drop-down list of magnifications, then touch the desired magnification to select it.

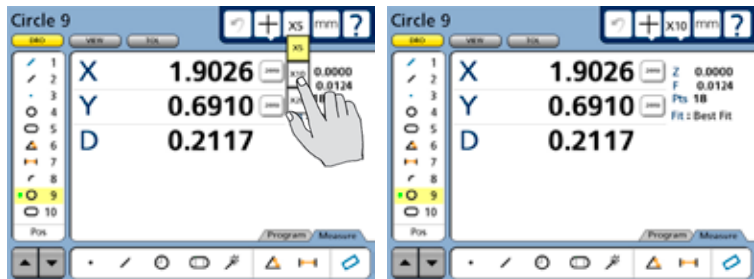

Touch a magnification button...

to select a magnification

Lighting

Adjust part illumination to achieve the best contrast between light and dark areas and to optimize the view of the part. This is important for all probes, but especially important for edge detection probes.



NOTE

The edge detector reference and sensor light levels can be checked using the Install function on the Magnification's setup screen. Refer to [Chapter 10: Setup](#) for details.

Calibration

Specification of encoder resolution is the first essential setup step explained in [Chapter 10: Setup](#).



NOTE

All the essential setup steps described at the beginning of [Chapter 10: Setup](#) must be performed before conducting measurements.

In some cases, it might also be necessary to perform error correction calibration to eliminate the effects of encoder and machine travel in accuracies.

Error correction can consist of a single linear error correction (LEC) applied across the entire range of motion on each axis, segmented linear error correction (SLEC) for individual segments of each axis, or nonlinear error correction (NLEC) applied over the entire X-Y plane. The need for, or type of error correction will depend on your system and your measurement applications. Error correction is explained in [Chapter 10: Setup](#).

Systems that contain optional edge detection probes require additional calibration. The extent of required edge detection calibration depends on your system and your measurement applications, and can include:

- Edge teach
- Distance calibration
- Cross calibration

Edge teach

Edge teach is a basic edge recognition calibration required by all edge detector systems. The edge teach should be performed at startup and when lighting, part, magnification or other conditions change. The edge teach process is performed using the tools in the Magnifications setup screen and is described in [Chapter 10: Setup](#). Edge teach can also be initiated from the Extra tab by touching the Teach icon.

The Extra tab is configured in the Display setup screen described in [Chapter 10: Setup](#).



Distance calibration

Distance calibrations are often required before measuring stick or round parts, or parts with indistinct or fuzzy edges. Distance calibration is performed using the Magnifications setup screen and is described in [Chapter 10: Setup](#).

Cross calibration

Cross calibration eliminates the location offset between crosshair and edge detection probes, and is required when both probe types will be used to probe the same part. Cross calibration is performed using the Magnifications setup screen and is described in [Chapter 10: Setup](#).

Probing with edge detectors

Points can be probed at light to dark or dark to light transitions using automatic or manual point entry.

Automatic point entry

To probe using edge detection and automatic point entry:

1 Select the auto point entry edge probe.

2 Teach the edge detector at the beginning of a measurement session, when lighting changes, when magnification changes or when other measurement conditions change.

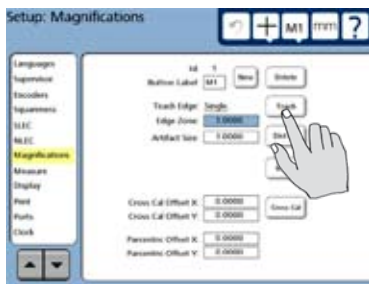

To teach the edge detector, enter setup, select the Magnifications screen and touch the Teach button. Follow instructions displayed on the screen to complete the Teach operation.

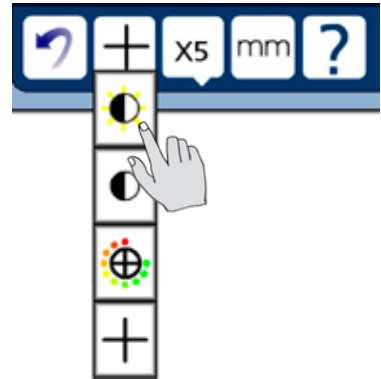

3 To measure, position the edge detector close to the first target edge, then touch the desired measure icon button.

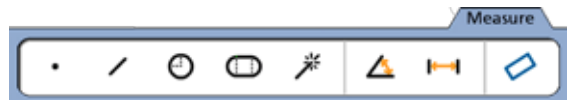

4 Move the edge probe across the target edge. The point will be entered.

5 Move to the next target edge.

Manual point entry

To probe using edge detection and manual point entry:

1 Select the manual point entry edge probe.

2 Teach the edge detector at the beginning of a measurement session, when lighting changes, when magnification changes or when other measurement conditions change.

To teach the edge detector, enter setup, select the Magnifications screen and touch the Teach button. Follow instructions displayed on the screen to complete the Teach operation.

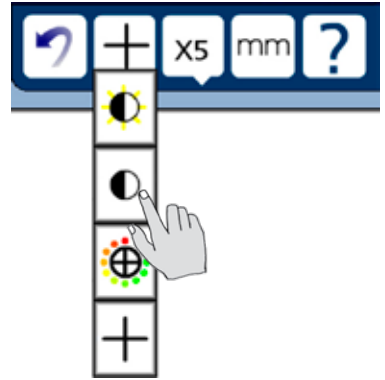
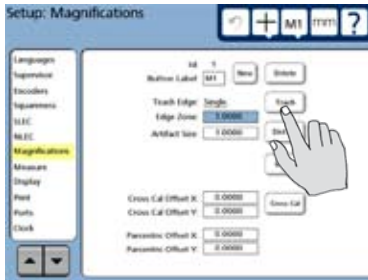

3 To measure, touch the desired measure icon button.

4 move the edge probe across the first target edge and then press the Enter key to collect the point.



5 Move to the next target edge.

Probing with crosshairs

Points can be probed using automatic or manual point entry.

Automatic point entry

To probe using crosshairs and automatic point entry:

1 Select the auto point entry crosshair probe.

2 Touch the desired measure icon button and then position the crosshair over the first target point. The animated probe button will show the crosshair timeout delay as a dot moving clockwise around the crosshair button until the delay is complete and the dot is positioned at 12:00. When the delay is complete, the point will be entered.

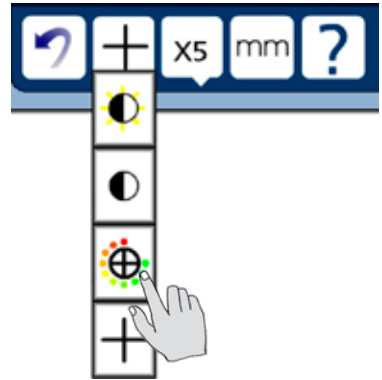
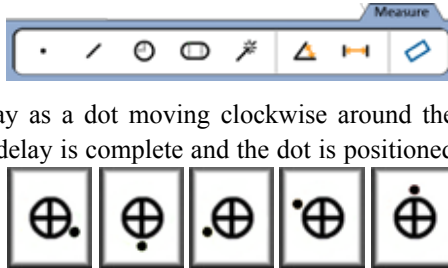

3 Move to the next target point. Use the Cancel key to erase points collected unintentionally.

Manual point entry

To probe using crosshairs and manual point entry:

1 Select the manual point entry crosshair probe.

Image

2 Touch the desired measure icon button, position the crosshair over the first target point and then press the Enter key.

3 Move to the next target point.

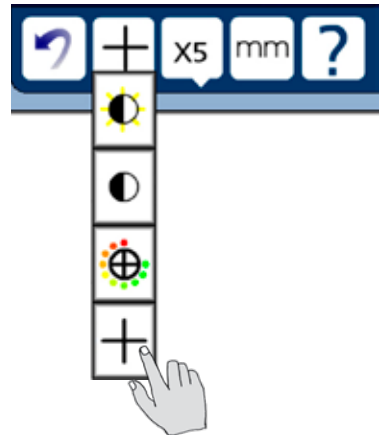

Chapter 6:

Measuring

Measurements can be performed manually or automatically (CNC option) using crosshairs or optional optical edge detection. Measurements can be limited to probing feature points, or can include the construction or creation of new features in addition to probing. However measurements are conducted, the fundamental measurement process and the tools required to perform measurements remain unchanged. Here's what you'll find in this chapter:

Measurement activities.....	52
The measurement process	52
Establishing the measurement reference	53
Leveling the part (optional)	53
Skewing the part	54
Creating a datum zero point	55
Probing and measuring features	58
Probing with Measure Magic.....	58
Probing specific feature types.....	59
Probing process.....	60
Probing with crosshairs and video edge detection	60
Probing specific feature types.....	60
Constructing features	70
Point constructions.....	70
Line constructions.....	79
Distance constructions	98
Circle constructions	115
Arc constructions	119
Angle constructions	119
Creating features	121
Creating a point.....	121
Creating a line.....	122
Creating a circle.....	122
Creating an arc	123
Creating a slot	123
Creating a rectangle	124

Measurement activities

QC-300 measurement sessions can include two or more of the following activities:

- Establishing a measurement reference
- Probing and measuring features
- Constructing features
- Creating features

The measurement process

The basic measurement process shown here is identical for all feature types. The details of individual measurement steps are described in the remaining pages of this section.

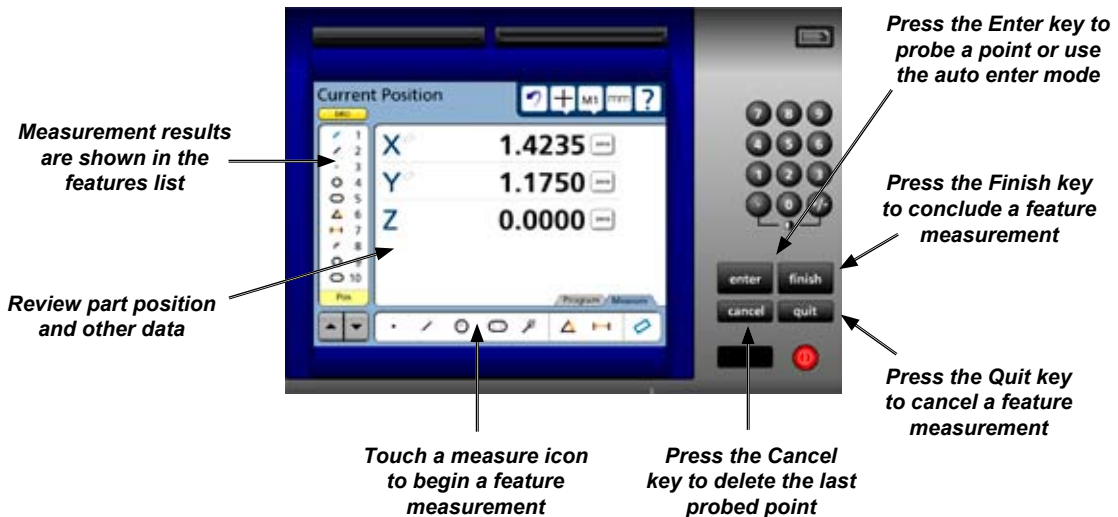
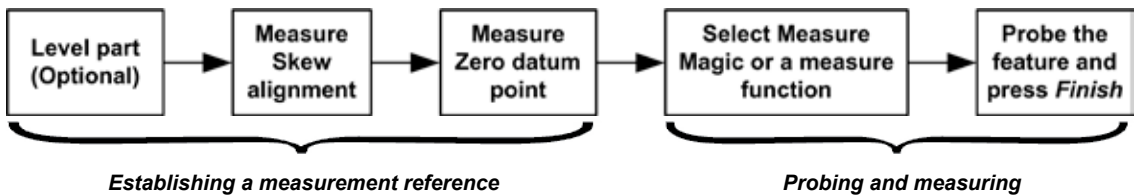

NOTE

Tools and controls for probing features and conducting measurements are discussed in [Chapter 3: User Interface](#), and [Chapter 5: Probes](#).



**NOTE**

When edge detection is used, the edge detection must be calibrated, and the optical system must be clean. The edge calibration is described in [Chapter 5: Probes](#).

Establishing the measurement reference

A reliable measurement reference must be established before part features can be probed and measured. This reference will be created by the user and ensures a level part surface, precise part alignment and a coordinate origin or datum zero. Reference features are presented in the feature list in blue, other features are presented in black.

Leveling the part (optional)

When the surface plane of the part is not orthogonal to the measurement axis, small cosine errors can be generated during the measuring process. These errors can be minimized or eliminated by leveling the part.

**CAUTION**

Leveling is optional in most well-maintained systems. Additionally, if the depth of field of the lens system is not much less than the level error, no benefit can be gained from leveling the part.

To level the part:

- 1 Touch the Measure Skew icon and then touch the Measure Level icon.

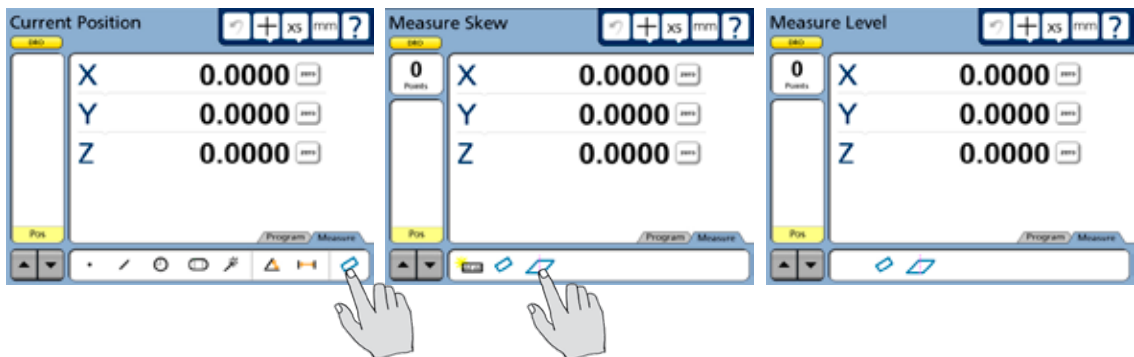

2 Touch the Level icon and perform the leveling measurement by probing three or more points that are well distributed across the surface of the desired part plane. Use the Crosshair to probe, move the Z-axis of the stage to focus the part surface under the Crosshair and then press the Enter key to enter each point. Press the Finish key to complete the level measurement. The level plane feature will be added to the Features list in blue.

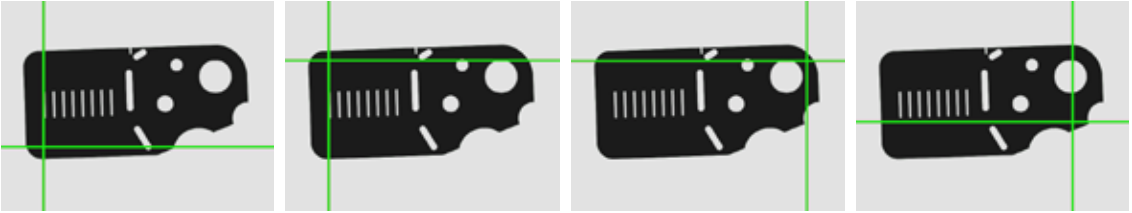

The four corners of the Metronics QC Quickie slide are probed to perform part leveling

Skewing the part

When the part is misaligned (twisted) in the X-Y plane, errors can be generated during the measurement process. These errors can be eliminated by creating a skew alignment for the part.

The skew alignment includes a precise measurement of the part misalignment. Once the misalignment is known to the system, subsequent feature measurements are automatically compensated to eliminate misalignment errors. Measurement data in the DRO will reflect measurements of a perfectly aligned part.

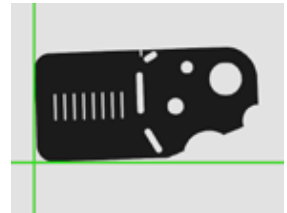

To skew the part:

1 Touch the Measure Skew icon.

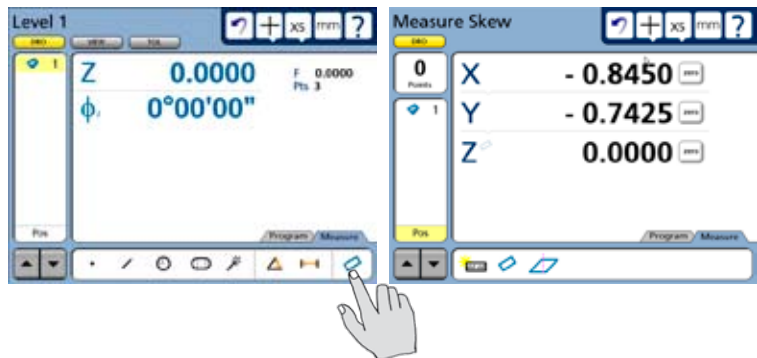

2 Perform the skew alignment by probing 2 or more points well distributed along the entire length of the desired part reference edge. Press the Enter key to enter each point. Press the Finish key to complete the Skew measurement. The skew line feature will be added to the Features list in blue.

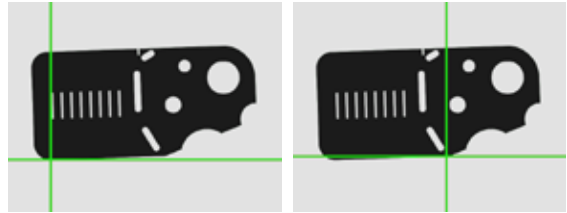

Two points are probed on the bottom edge to perform a skew alignment on the X-axis

Creating a datum zero point

Creating the datum zero point is the final step in establishing a valid Cartesian or polar coordinate system for subsequent measurements. The datum zero point will be used as the origin of Cartesian or polar systems. The datum zero point can be positioned in any location that satisfies the measurement requirements of the user and can be created by probing a point or by constructing a point from parent features.

Probing a datum zero point

The datum zero point can sometimes be created directly by probing a point. Simple probing is more often possible when the part is precisely aligned in the stage.

To probe a datum zero point:

1 Touch the Measure Point icon.

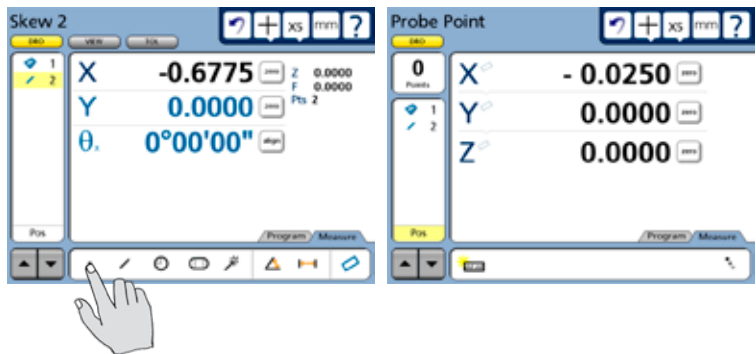

2 Use the crosshair to probe the desired point for the datum zero, and then press the Finish key. The point will be added to the Features list in blue.

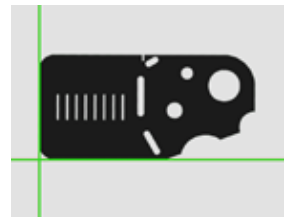

3 While the point feature is selected touch the X and Y axis Zero buttons to establish a datum zero at the probed point.

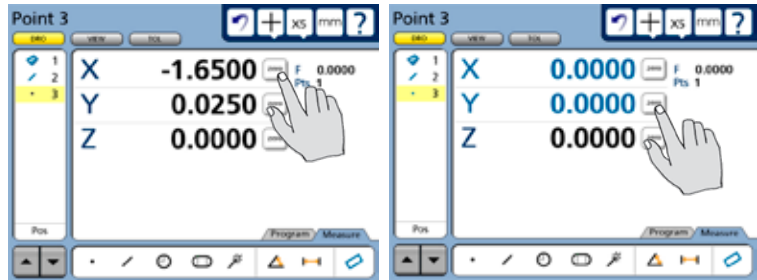

Constructing a datum zero point

The datum zero point can be constructed from parent features when simply probing the desired point is not practical.

It would not be possible to provide a single description of this process for all measurement applications that require feature constructions to create a datum zero point. However, the concept illustrated by the following example and the construction techniques described later in this chapter can be used to construct a datum zero point for any measurement application.

In this example, after the part skew is performed, a datum zero point is constructed at the intersection points of the X-axis along the bottom of the part (skew axis), and the Y-axis along the left side of the part.

To construct the datum zero point:

1 Touch the Measure Magic or the Measure Line icon.

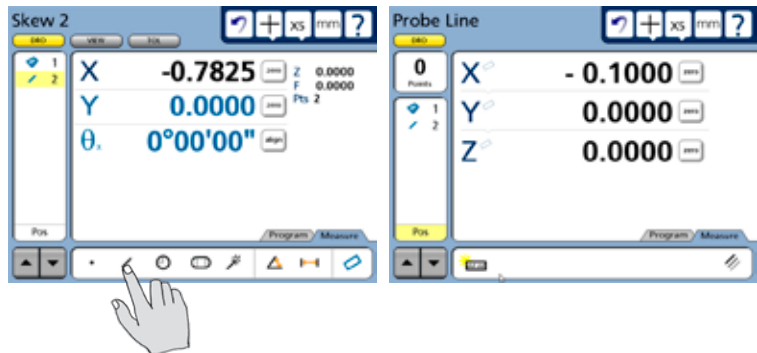

2 Probe two or more points well distributed along the left side of the part, and then press the Finish button. The line feature will be added to the Features list.

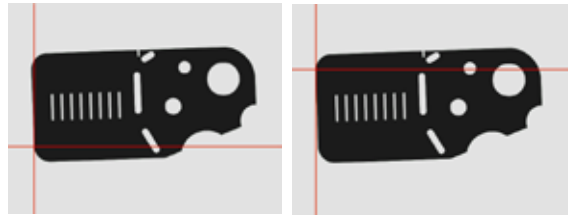

3 Touch the Measure Point icon, and then touch each of the two lines in the feature list to checkmark them.

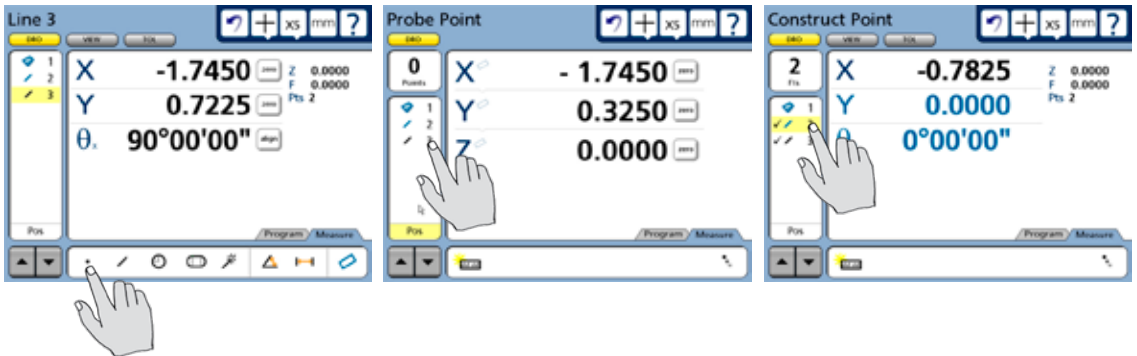

4 Press the Finish key to complete the point construction.

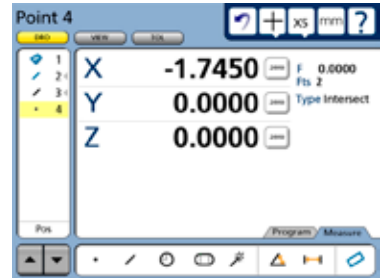

5 While the constructed point is selected, touch the Zero buttons of the X and Y axes to define the point's location as the zero datum. Select the View window to see the zero datum at the intersection of the X and Y axes.

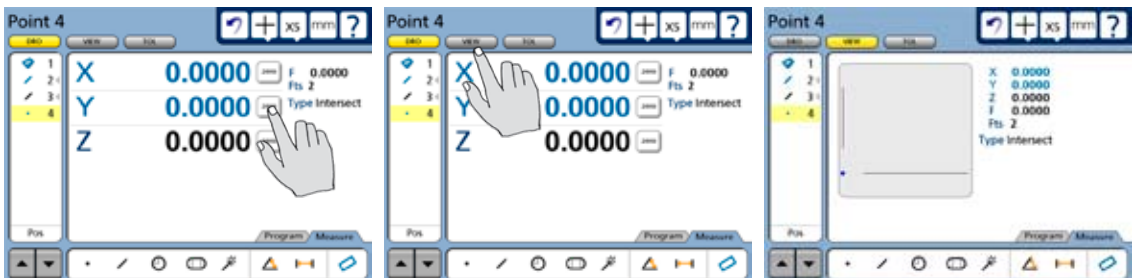

Probing and measuring features

Part features are measured by creating a part datum, and then by probing points that define the feature's shape and location. Feature points can be probed using Measure Magic or by using a specific measurement function such as the line or circle function. Measurement functions or measure magic are selected by touching a measure icon in the measure toolbar. Measurement results are shown in the Feature list, DRO window and View window.

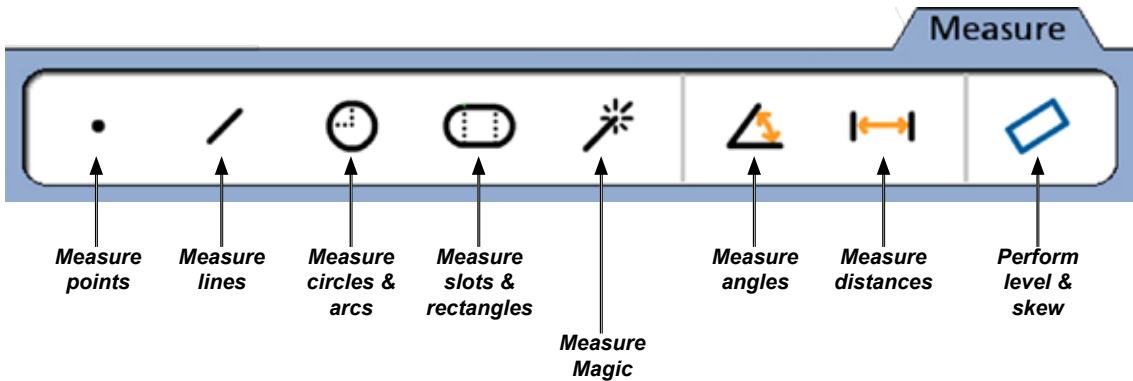

The measure toolbar contains icons for measurement functions and measure magic

Probing with Measure Magic

Measure Magic analyzes feature data collected by part probing and automatically determines the feature type. Measure Magic supports the following feature types in the QC-300:

- Points
- Lines
- Circles
- Arcs
- Slots

When Measure Magic is used, and more than the minimum number of points required to define a feature type are collected, the feature type can be changed manually by the user if the wrong feature type is assigned.

To probe a feature using measure magic, touch the measure magic measure icon, probe points on the desired feature and then press the Finish key.



Probing specific feature types

When measure magic is not used a measure icon must be touched before each specific feature type is probed. However, a series of features of the same type can be probed by touching the desired measure icon and then touching multiple measurement icon.

Probing a single specific feature type

To probe a single feature of a specific type, touch the desired measure icon, probe points on the feature and then press the Finish key. A measure icon must be touched again to measure the next feature.



In this example the circle icon is touched to measure a single circle.

When a specific measure function is used to probe the feature, the feature type cannot be changed once it is added to the feature list.

Probing multiple specific feature types

To probe a series of features of a specific type, touch the desired measure icon, touch the multiple measurement icon, probe points on each feature pressing the Finish key to conclude each feature measurement. In this example icons are touched to probe multiple circles.



Touch the circle icon for circle measurements...

and then touch the multiple measurement icon to measure a series of circle features

When a specific measure function is used to probe a series of similar features, the feature type cannot be changed once features have been added to the feature list.

Probing process

The feature probing process is essentially the same for all feature types.

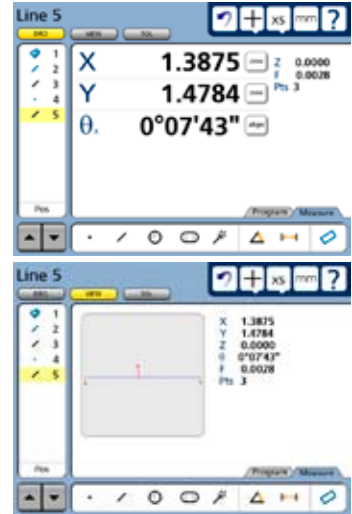
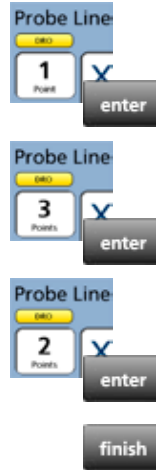
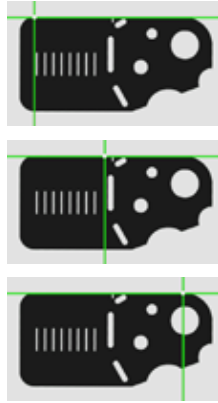
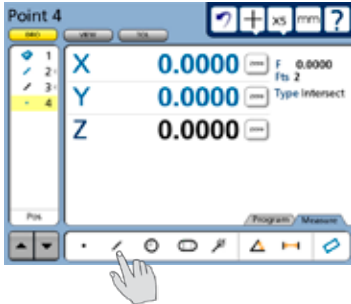

Touch the desired measure icon

Probe and enter features, then press Finish to complete measurements

Results are displayed in the DRO and View windows

Supported feature types

The following feature measurements are supported by the QC-300:

- Points
- Lines
- Arcs
- Circles
- Slots
- Rectangles
- Distances
- Angles

Features can be probed manually or semi-automatically as part of a program.



NOTE

Manual probing is discussed in Chapter 5: Probes. Semi-automatic probing is discussed in Chapter 8: Programming.

Backward/forward annotation

Forward annotation is used to specify a required number of probed points for each feature type. Backward annotation allows the user to probe any number of points beyond the minimum requirement for any feature type. When using forward annotation, the number of remaining required points is shown at the top left of the screen. As points are probed this number counts down. Backward annotation simply displays the number of points as they are entered. Some users prefer forward annotation because it establishes a uniform number of points for feature measurements. For example, forward annotation can be set to require 4 points when measuring a circle instead of the minimum three.

When forward annotation is used, the system automatically displays the feature after the last required point is entered. It is not necessary to press the Finish key to conclude forward annotation measurements.



NOTE

Users can toggle between backward and forward annotation in the Measure setup screen. Please refer to Chapter 10: Setup for more information regarding backward and forward annotation.

Probing with crosshairs and optical edge detection

Please refer to Chapter 5: Probes for details regarding probing features with crosshairs and optical edge detection. Images used as examples in this chapter show crosshairs. However, the measuring concepts apply equally well to crosshair and optical edge detection probes.

Optical edge detection provides additional flexibility in terms of acquiring points reliably on feature edges. Please refer to Chapter 5: Probes for more details regarding optical edge detection.

Probing specific feature types

While the probing process is essentially the same for all feature types, the minimum number of points required and the geometric placement of these points are different. The unique requirements for probing each feature type are described in the remainder of this section.

Probing points

A minimum of one probed point is required to measure a point. Multiple points can be probed if the feature location is indistinct and it is considered a benefit to use the geometric average of many probed locations.

When a single point is probed, Measure Magic will correctly recognize a point and assign the correct feature. However, when multiple points are probed, it is possible that the wrong feature type will be assigned. If the wrong feature type is assigned, it can easily be changed by selecting the correct feature from a menu of alternatives in the DRO window.

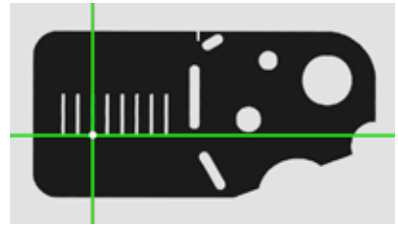

A single point is probed to measure a point

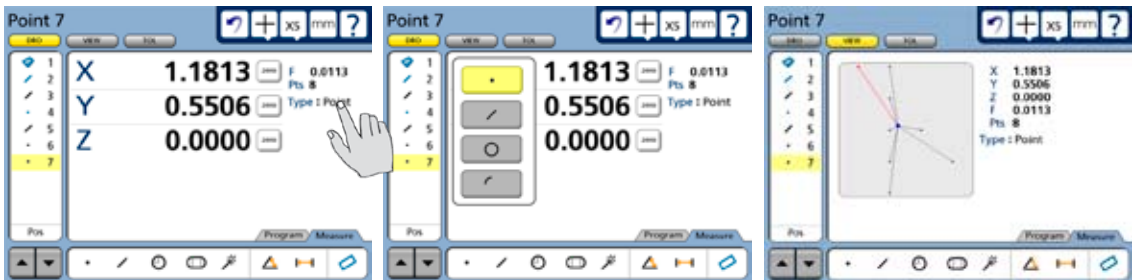

Touch the feature type...

to display the menu of alternative types

Probed points are shown in the View window

Measurement results are shown in the Feature list, View window and DRO window. The feature graphic in the View window shows the feature and the points used to define it. Errors are shown as whiskers connecting the probed points to the feature. The maximum errors are shown in red and are used in the calculation of form. The DRO window shows the number of points used, the form and the coordinate location of the feature. When only one point is probed, the form error is zero. When more than one point is probed, the form error is the sum of the two greatest opposing error magnitudes.

Probing lines

A minimum of two probed points is required to measure a line. There is no practical limit to the number of points that can be probed, and in general accuracy is increased by probing more points.

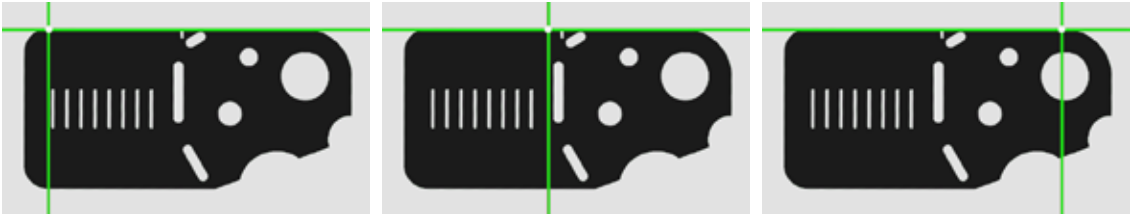

In this example, three points are probed to measure a line

When only two points are probed, Measure Magic will correctly recognize a line and assign the correct feature. However, when more than two points are probed, it is possible that the wrong feature type will be assigned. If the wrong feature type is assigned, it can easily be changed by selecting the correct feature from a menu of alternatives in the DRO window.

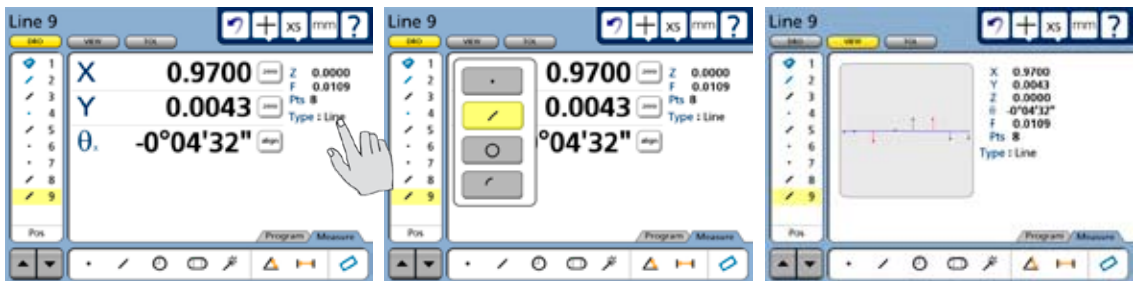

Touch the feature type...

to display the menu of alternative types

Probed points are shown in the View window

Best-fit algorithms are used to define lines when more than two points are probed. The line fit to the probed data can also be changed by selecting the desired fitting algorithm from a menu in the DRO window. Please refer to [Chapter 12: Reference Materials](#) for details regarding the fitting algorithms.

Measurement results are shown in the Feature list, View window and DRO window. The feature graphic in the View window shows the feature and the points used to define it. Errors are shown as whiskers connecting the probed points to the feature. The maximum errors are shown in red and are used in the calculation of form. The DRO window shows the number of points used, the angular orientation of the line, the coordinate location of the center of the line and the form error. When only two points are probed, the form error is zero. When more than two points are probed, the form error is the sum of the two greatest opposing error magnitudes.

Probing arcs

A minimum of three probed points is required to measure an arc. There is no practical limit to the number of points that can be probed, and in general accuracy is increased by probing more points.

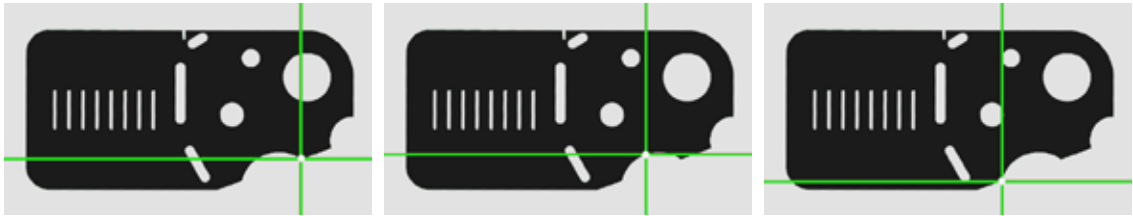

In this example, three points are probed to measure an arc

When the arc is less than 185 degrees, Measure Magic will correctly recognize the arc and assign the correct feature. However, when the arc is 185 degrees or more, it is likely that Measure Magic will assign the circle feature type to the data. If the arc is shallow, Measure Magic might mistakenly assign a line feature. If the wrong feature type is assigned, it can easily be changed by selecting the correct feature from a menu of alternatives in the DRO window.

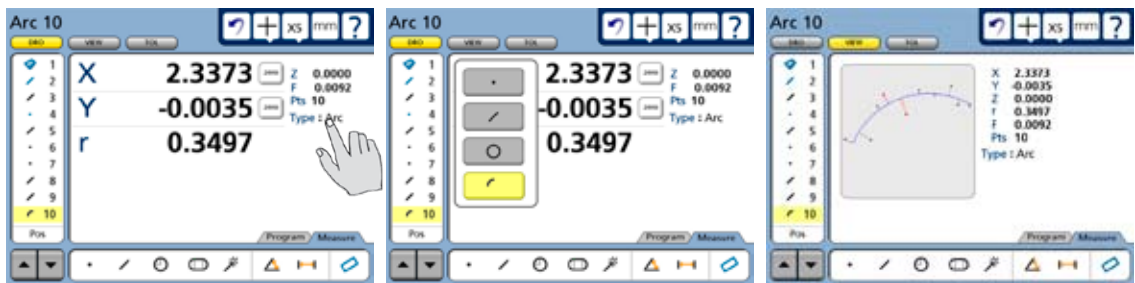

Touch the feature type...

to display the menu of alternative types

Probed points are shown in the View window

The View window shows the feature and the points used to define it. Errors are shown as whiskers connecting the probed points to the feature. The arc will be shown with data point form errors in blue and the greatest two opposing form errors in red.

Measurement results are shown in the Feature list, View window and DRO window. The DRO window shows the number of points used, the radius and diameter of the arc, the coordinate location of the center of the arc and the form error. The feature graphic in the View window shows the feature and the points used to define it. Errors are shown as whiskers connecting the probed points to the feature. The maximum errors are shown in red and are used in the calculation of form. When only three points are probed, the form error is zero. When more than three points are probed, the form error is the sum of the two greatest opposing error magnitudes.

Probing circles

A minimum of three probed points is required to measure a circle. There is no practical limit to the number of points that can be probed, and in general accuracy is increased by probing more points.

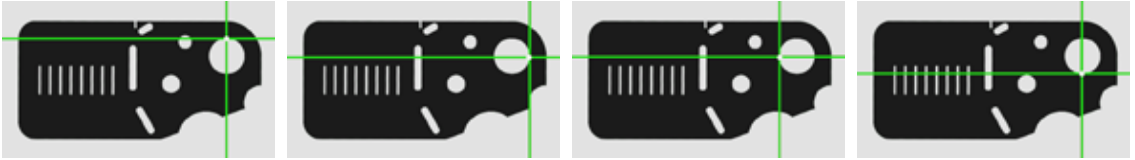

In this example, four points are probed to measure a circle

When 185 degrees or more of the circle is probed, Measure Magic will correctly recognize the circle and assign the correct feature. However, when less than 185 degrees is probed, it is likely that Measure Magic will assign the arc feature type to the data. If the wrong feature type is assigned, it can easily be changed by selecting the correct feature from a menu of alternatives in the DRO window.

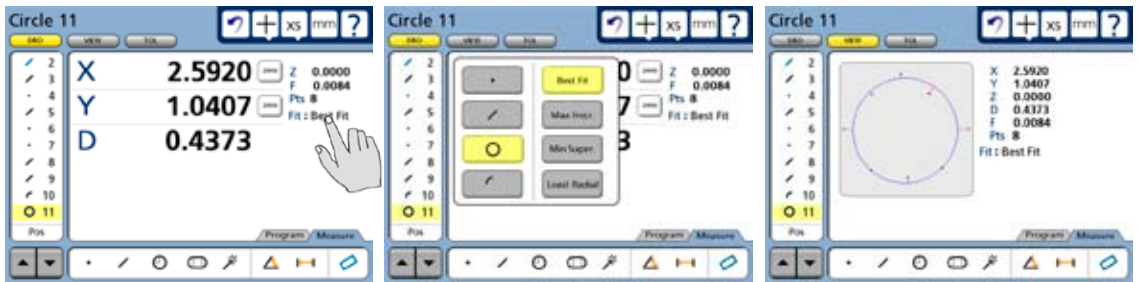

Touch the feature type...

to display the menu of alternative types

Probed points are shown in the View window

A best-fit algorithm is used to define the circle when more than three points are probed. The circle fit to the probed data can also be changed by selecting the desired fitting algorithm from a menu in the DRO window. Please refer to [Chapter 12: Reference Materials](#) for details regarding the fitting algorithms.

The View window shows the feature and the points used to define it. Errors are shown as whiskers connecting the probed points to the feature. The circle will be shown with data point form errors in blue and the greatest two opposing form errors in red.

Measurement results are shown in the Feature list, View window and DRO window. The feature graphic in the View window shows the feature and the points used to define it. Errors are shown as whiskers connecting the probed points to the feature. The maximum errors are shown in red and are used in the calculation of form. The DRO window shows the number of points used, the radius, diameter, coordinate location of the center of the circle and the form error. When only three points are probed, the form error is zero. When more than three points are probed, the form error is the sum of the two greatest opposing error magnitudes.

Probing slots

Five probed points are required to measure a slot. The five points must be probed in a prescribed pattern, and must be probed in a clockwise or counterclockwise sequence.



As shown above, the correct pattern of points probed around the slot is:

- Two points well distributed along one long side, followed by
- One point on the closest end, followed by
- One point on the approximate center of the second long side, followed by
- The last point on the remaining end



CAUTION

Probing a different pattern of points, or probing out of either clockwise or counterclockwise order will result in erroneous slot measurements.

When the slot is probed as described above, Measure Magic will assign the correct feature. However, occasionally Measure Magic will assign the wrong feature type to the data. If the wrong feature type is assigned, it can easily be changed by selecting the correct feature from a menu of alternatives in the DRO window.

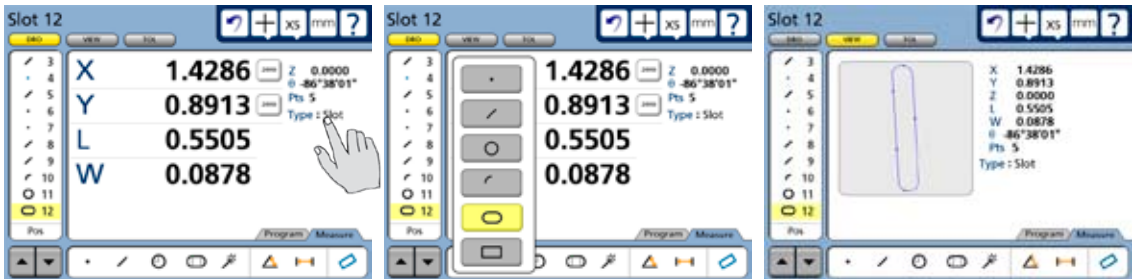

Touch the feature type...

to display the menu of alternative types

Probed points are shown in the View window

Measurement results are shown in the Feature list, View window and DRO window. The feature graphic in the View window shows the feature and the points used to define it. The DRO window shows the number of points probed, the coordinate location of the center of the slot, the slot length, the slot width and the angle of the slot center line with respect to the skew axis.

Probing rectangles

Five probed points are required to measure a rectangle. The five points must be probed in a prescribed pattern, and must be probed in a clockwise or counterclockwise sequence.



As shown above, the correct pattern of points probed around the rectangle is:

- Two points well distributed along one long side, followed by
- One point on the closest end, followed by
- One point on the approximate center of the second long side, followed by
- The last point on the remaining end



CAUTION

Probing a different pattern of points, or probing out of either clockwise or counterclockwise order will result in erroneous rectangle measurements.

When the rectangle is probed as described above using Measure Magic, Measure Magic will assign the slot feature. However, the slot feature can easily be changed to a rectangle by selecting the rectangle feature from a menu of alternatives in the DRO window.

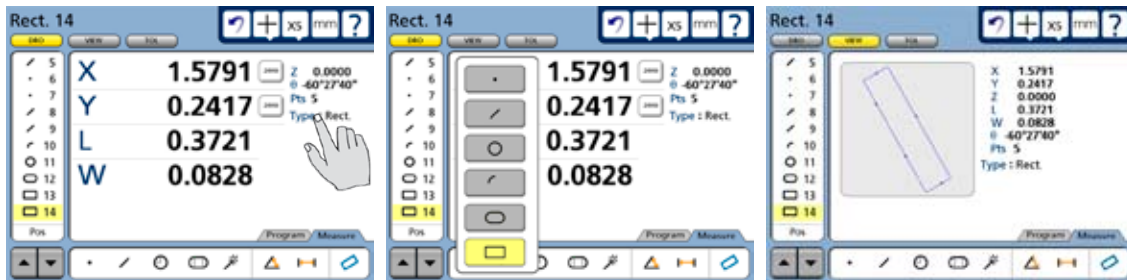

Touch the feature type...

to select the correct rectangle feature type

Probed points are shown in the View window

Measurement results are shown in the Feature list, View window and DRO window. The feature graphic in the View window shows the feature and the points used to define it. The DRO window shows the number of points probed, the coordinate location of the center of the rectangle, the rectangle length, the rectangle width and the angle of the rectangle center line with respect to the skew axis.

Probing distances

Two probed points are required to measure a distance.

Measurement results are shown in the Feature list, View window, and the DRO window.

The View window shows the feature and the points used to define it. The DRO window shows the number of points used, the X and Y axis displacements and the distance vector between features.

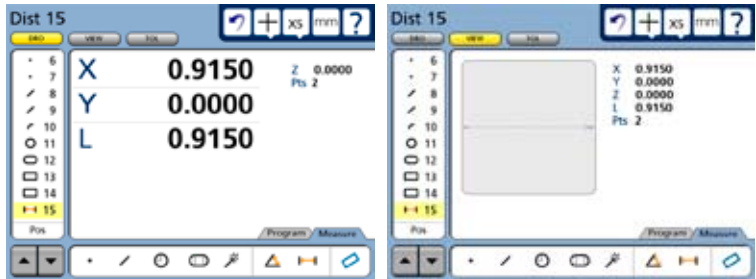
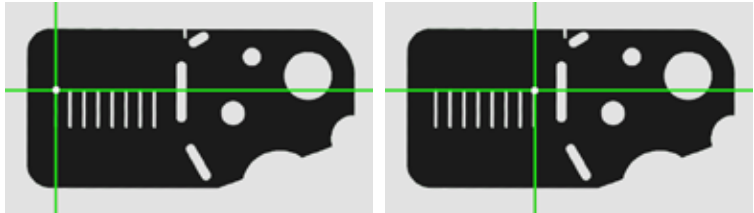

Probing angles

A minimum of four probed points are required to measure an angle. The points must be probed in a prescribed pattern on the two lines that form an angle. There is no practical limit to the number of points that can be probed, and in general accuracy is increased by probing more points.

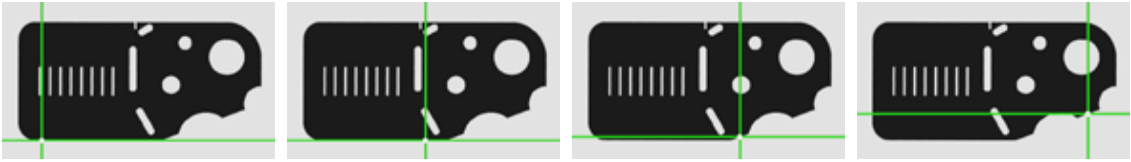

Probe the first points on the reference side and press the Finish key...

and then probe points on the other side of the included angle and press Finish again

As shown here, the correct pattern of points probed for an angle is:

- A minimum of two points well distributed along the reference side, followed by
- A minimum of two points well distributed along the opposite side of the included angle

The View window shows the feature and the points used to define it. The DRO window shows the number of points probed, the coordinate location of the angle and the angle orientation to the skew axis.

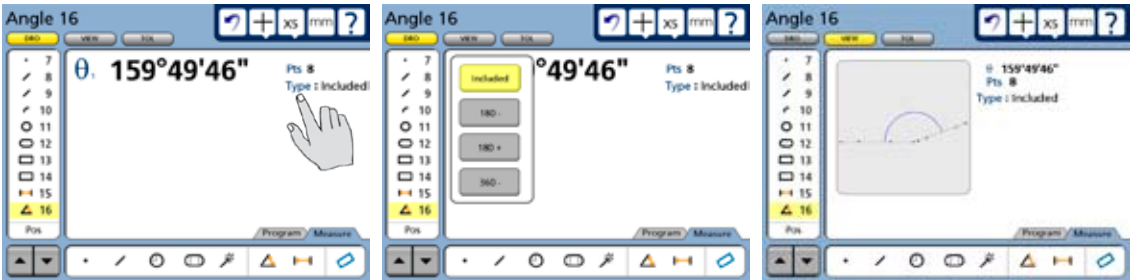

Touch the angle type...

to select the desired angle type

Probed points are shown in the View window

The included angle is shown as the default measurement result, however, the angle type can easily be changed by selecting the desired angle type from a menu of alternatives in the DRO window.

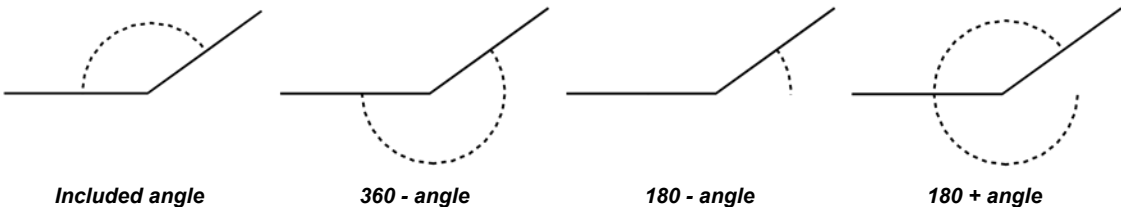

Constructing features

Features can be constructed from one or more existing features. Existing features used to construct new features are called parent features, and can be features that were measured, constructed or created. Existing features are shown in black, and constructed features are shown in blue in the View window.

Point constructions

Points can be constructed from:

- Points
- Lines
- Distances
- Circles
- Angles
- Arcs
- Slots
- Rectangles

Point constructed from a point

A duplicate feature can be useful when it becomes desirable to perform new operations with the original while retaining a copy. To construct a point from an existing point:

- 1 Touch the Measure Point icon
- 2 Touch the desired point in the Features list
- 3 Press the Enter key
- 4 Press the Finish key

The new point feature will be constructed over the original point.

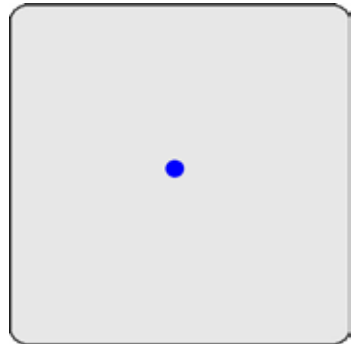

Point constructed from a point and a line

The point will be constructed where the perpendicular from the original point intersects the line or its extension.

To construct a point from an existing point and a line:

- 1 Touch the Measure Point icon
- 2 Touch the desired point feature
- 3 Touch the desired line feature
- 4 Press the Enter key
- 5 Press the Finish key

The new point feature will be constructed on the line.

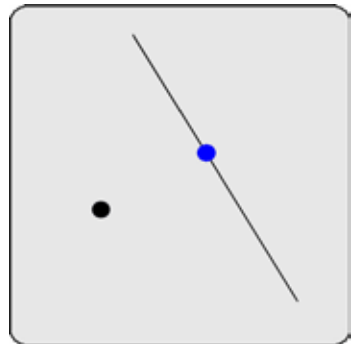

Points constructed from an arc and a line

Up to three point constructions can be made from an arc and a line:

- Intersection point 1:
The first intersection of the arc and line
- Intersection point 2:
The second intersection of the arc and line
- Perpendicular point:
The intersection of the line and the perpendicular from the arc center to the line

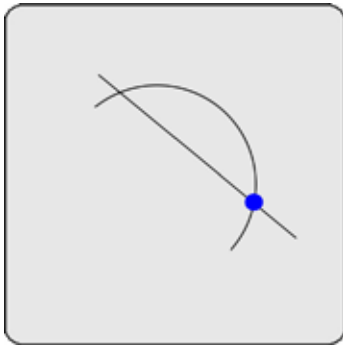

Intersection point 1

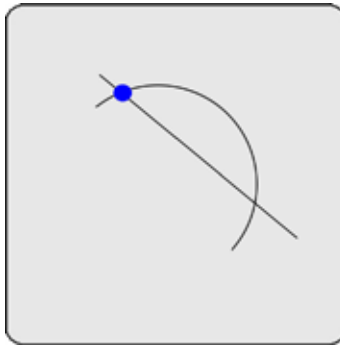

Intersection point 2

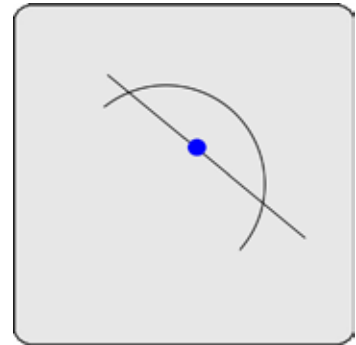

Perpendicular point

To construct a point from an arc and a line:

- 1 Touch the Measure Point icon
- 2 Touch the desired arc feature
- 3 Press the Enter key
- 4 Touch the desired line feature
- 5 Press the Enter key
- 6 Press the Finish key

The first intersect point or perpendicular point of the arc and line will be constructed. Alternative point constructions can be selected from the drop-down menu in the DRO window.

Points constructed from a line

Up to four point constructions can be made from a line:

- Midpoint:
The center of the line
- End point 1:
The first endpoint of the line
- End point 2:
The second endpoint of the line
- Anchor point:
The intersection of the line and the perpendicular from the datum to the line

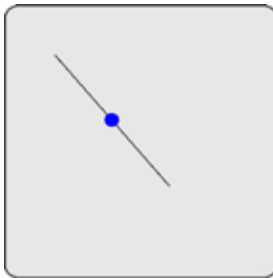

Midpoint

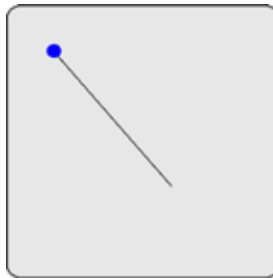

End point 1

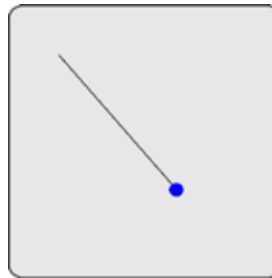

End point 2

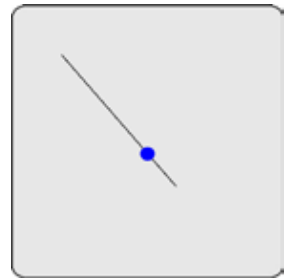

Anchor point

To construct a point from a line:

- 1 Touch the Measure Point icon
- 2 Touch the desired line feature
- 3 Press the Enter key
- 4 Press the Finish key

The midpoint of the line will be constructed. Alternative point constructions can be selected from the drop-down menu in the DRO window.

Point constructed from two lines

The intersection point of the lines will be constructed. The virtual intersection point will be calculated and shown if the lines do not actually cross.

To construct a point from two lines:

- 1 Touch the Measure Point icon
- 2 Touch one desired line feature
- 3 Press the Enter key
- 4 Touch the other line feature
- 5 Press the Enter key
- 6 Press the Finish key

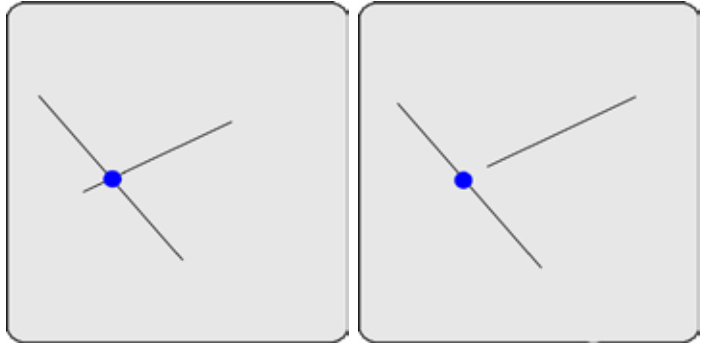

The intersection point or virtual intersection point of the lines will be constructed.

Points constructed from a distance

The start and end points of the distance will be constructed.

To construct points from a distance:

- 1 Touch the Measure Point icon
- 2 Touch the distance feature
- 3 Press the Enter key
- 4 Press the Finish key

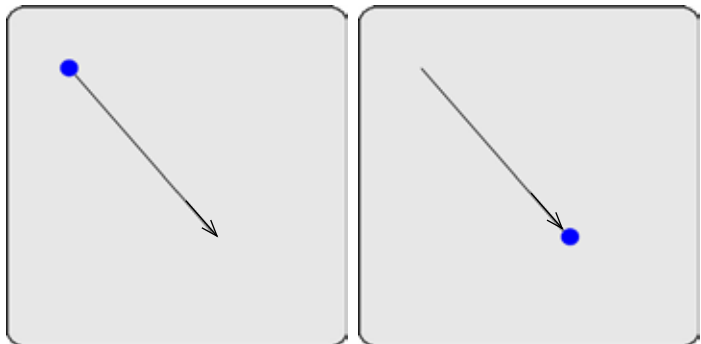

The start point of the line will be constructed. The alternative end point construction can be selected from the drop-down menu in the DRO window.

Point constructed from a distance and a point

A point feature will be constructed and offset from the parent point feature by the parent distance feature.

To construct a point from a point and a distance:

- 1 Touch the Measure Point icon
- 2 Touch the point feature
- 3 Press the Enter key
- 4 Touch the distance feature
- 5 Press the Enter key
- 6 Press the Finish key

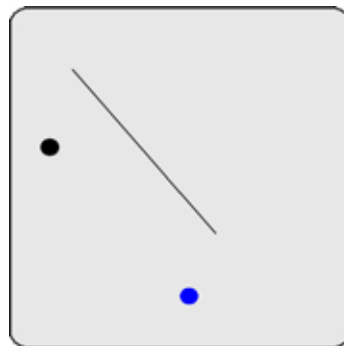

An offset point feature will be constructed.

Point constructed from a circle

A point feature will be constructed at the center of a circle.

To construct a point from a circle:

- 1 Touch the Measure Point icon
- 2 Touch the circle feature
- 3 Press the Enter key
- 4 Press the Finish key

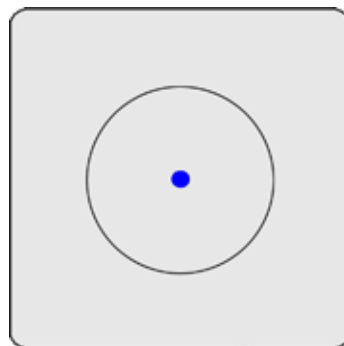

A point feature will be constructed at the center of the circle.

Points constructed from a circle and a line

Up to three point constructions can be made from an circle and a line:

- Intersection point 1:
The first intersection of the circle and line
- Intersection point 2:
The second intersection of the circle and line
- Perpendicular point:
The intersection of the line and the perpendicular from the circle center to the line

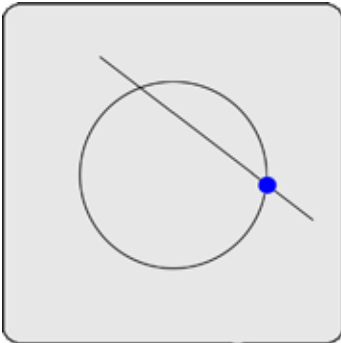

Intersection point 1

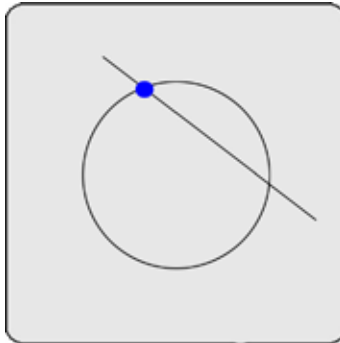

Intersection point 2

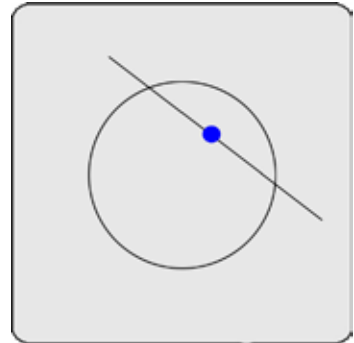

Perpendicular point

To construct a point from an circle and a line:

- 1 Touch the Measure Point icon
- 2 Touch the desired circle feature
- 3 Press the Enter key
- 4 Touch the desired line feature
- 5 Press the Enter key
- 6 Press the Finish key

The first intersect point or perpendicular point of the circle and line will be constructed. Alternative point constructions can be selected from the drop-down menu in the DRO window.

Points constructed from two circles

Up to three point constructions can be made from two circles:

- Intersection point 1:
The first intersection of the two circles
- Intersection point 2:
The second intersection of the two circles
- Midpoint:
The midpoint of the congruent portion of the two circles

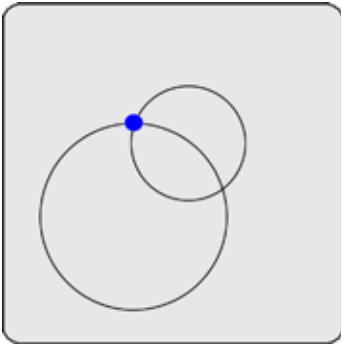

Intersection point 1

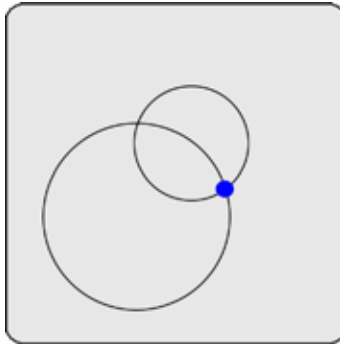

Intersection point 2

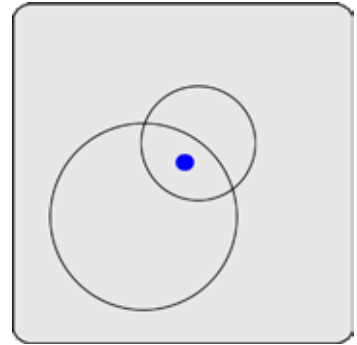

Midpoint

To construct a point from two circles:

- 1 Touch the Measure Point icon
- 2 Touch the first circle feature
- 3 Press the Enter key
- 4 Touch the second circle feature
- 5 Press the Enter key
- 6 Press the Finish key

The first intersect point of the two circles will be constructed. Alternative point constructions can be selected from the drop-down menu in the DRO window.

Point constructed from a slot

A point feature will be constructed at the center of a slot.

To construct a point from a slot:

- 1 Touch the Measure Point icon
- 2 Touch the slot feature
- 3 Press the Enter key
- 4 Press the Finish key

A point feature will be constructed at the center of the slot.

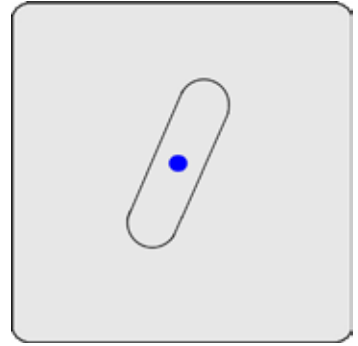
**Point constructed from a rectangle**

A point feature will be constructed at the center of a rectangle.

To construct a point from a slot:

- 1 Touch the Measure Point icon
- 2 Touch the rectangle feature
- 3 Press the Enter key
- 4 Press the Finish key

A point feature will be constructed at the center of the rectangle.

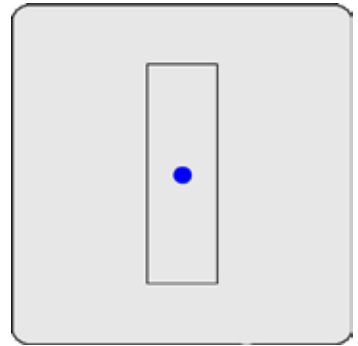
**Point constructed from an angle**

A point feature will be constructed at the apex of the angle.

To construct a point from an angle:

- 1 Touch the Measure Point icon
- 2 Touch the angle feature
- 3 Press the Enter key
- 4 Press the Finish key

A point feature will be constructed at the apex of the angle.

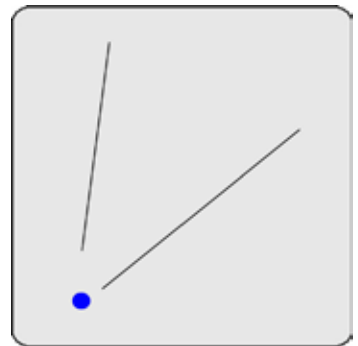

Point constructed from an arc

A point feature will be constructed at the center of an arc.

To construct a point from an arc:

- 1 Touch the Measure Point icon
- 2 Touch the arc feature
- 3 Press the Enter key
- 4 Press the Finish key

A point feature will be constructed at the center of the arc.

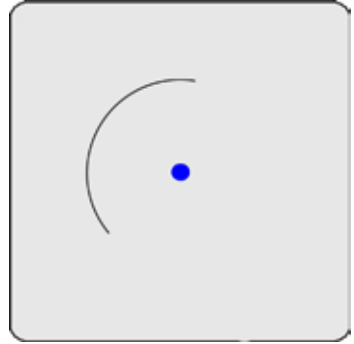
**Point constructed from multiple features**

The geometric center point of multiple features can be constructed from any combination and any number of points, slots, rectangles, circles, and arcs.

To construct a point from multiple features:

- 1 Touch the Measure Point icon
- 2 Touch a feature
- 3 Press the Enter key
- 4 Repeat steps 2 and 3 for all features
- 5 Press the Finish key

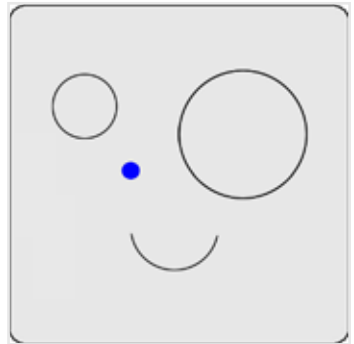

The center point (centroid) of the entire collection of features will be constructed.

Line constructions

Lines can be constructed from:

- Points
- Lines
- Distances
- Circles
- Angles
- Arcs
- Slots

Line constructed from a line

A duplicate feature can be useful when it becomes desirable to perform new operations with the original while retaining a copy. To construct a line from an existing line:

- 1 Touch the Measure Line icon
- 2 Touch the desired line in the Features list
- 3 Press the Enter key
- 4 Press the Finish key

The new line feature will be constructed over the original line.

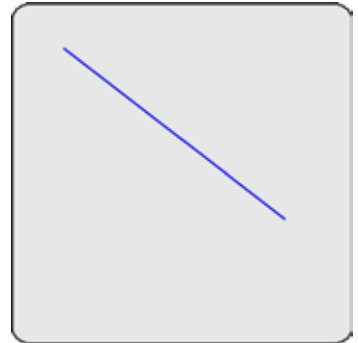

Line constructed from two points

The line feature will be constructed between the two points.

To construct a line from two points:

- 1 Touch the Measure Line icon
- 2 Touch the first point Feature
- 3 Press the Enter key
- 4 Touch the second point Feature
- 5 Press the Enter key
- 6 Press the Finish key

The new line feature will be constructed between the two points.

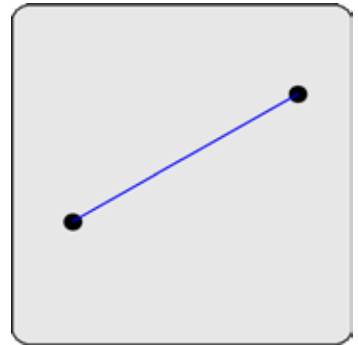

Lines constructed from a point and a line

Two line constructions can be made from a point and a line:

- Perpendicular line:
The line from the point to the line, perpendicular to the line
- Parallel line:
The line through the point parallel to the line

To construct a line from a point and a line:

- 1 Touch the Measure Line icon
- 2 Touch the point feature
- 3 Press the Enter key
- 4 Touch the line feature
- 5 Press the Enter key
- 6 Press the Finish key

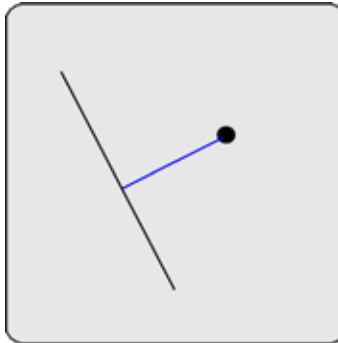

Perpendicular line

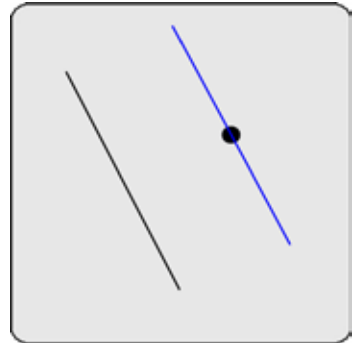

Parallel line

The perpendicular line will be constructed. The alternative parallel line construction can be selected from the drop-down menu in the DRO window.

Line constructed from a distance

The line feature will be constructed over a distance feature.

To construct a line from a distance:

- 1 Touch the Measure Line icon
- 2 Touch the distance Feature
- 3 Press the Enter key
- 4 Press the Finish key

The new line feature will be constructed over the distance feature.

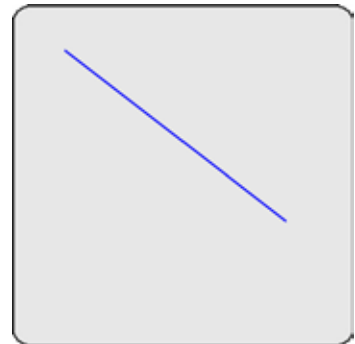

Lines constructed from a point and a circle

Up to three line constructions can be made from a point and a circle:

- Two point line:
The line from the point to the center of the circle
- Tangent line 1:
The line from the point to the first tangent of the circle
- Tangent line 2:
The line from the point to the second tangent of the circle

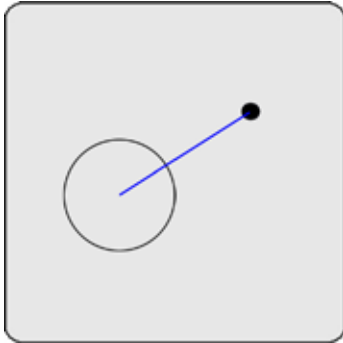

Two point line

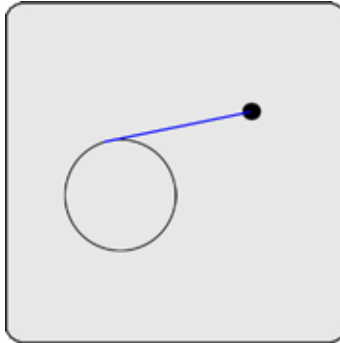

Tangent line 1

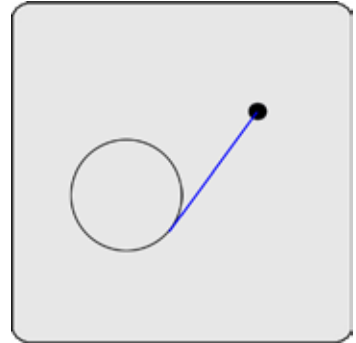

Tangent line 2

To construct a line from a point and a circle:

- 1 Touch the Measure line icon
- 2 Touch the point feature
- 3 Press the Enter key
- 4 Touch the circle feature
- 5 Press the Enter key
- 6 Press the Finish key

The two point line will be constructed. Alternative line constructions can be selected from the drop-down menu in the DRO window.

Line constructed from a point and a slot

The line will be constructed from the point to the center of the slot.

To construct a line from a point and a slot:

- 1 Touch the Measure line icon
- 2 Touch the point feature
- 3 Press the Enter key
- 4 Touch the slot feature
- 5 Press the Enter key
- 6 Press the Finish key

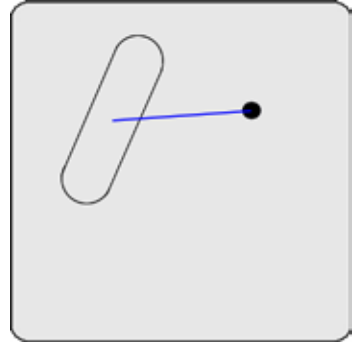

The line will be constructed to the center of the slot.

Line constructed from a point and a rectangle

The line will be constructed from the point to the center of the rectangle.

To construct a line from a point and a rectangle:

- 1 Touch the Measure line icon
- 2 Touch the point feature
- 3 Press the Enter key
- 4 Touch the rectangle feature
- 5 Press the Enter key
- 6 Press the Finish key

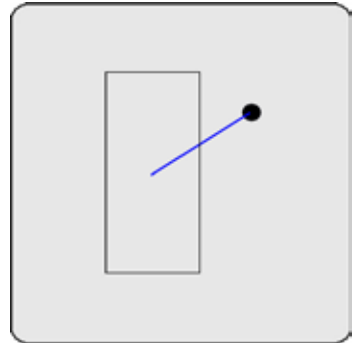

The line will be constructed to the center of the rectangle.

Lines constructed from a point and an arc

Up to three line constructions can be made from a point and an arc:

- Two point line:
The line from the point to the center of the arc
- Tangent line 1:
The line from the point to the first tangent of the arc
- Tangent line 2:
The line from the point to the second tangent of the arc

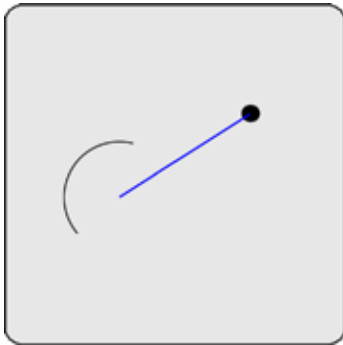

Two point line

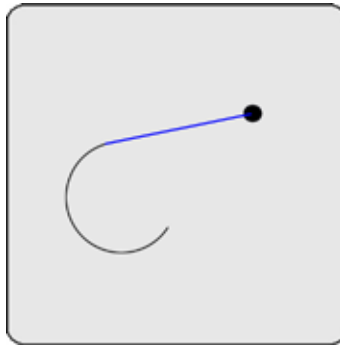

Tangent line 1

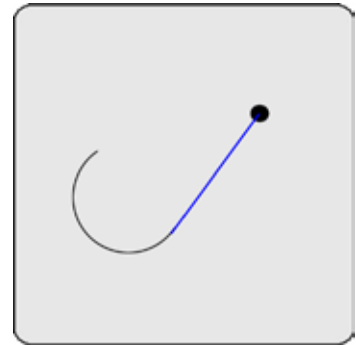

Tangent line 2

To construct a line from a point and an arc:

- 1 Touch the Measure line icon
- 2 Touch the point feature
- 3 Press the Enter key
- 4 Touch the arc feature
- 5 Press the Enter key
- 6 Press the Finish key

The two point line will be constructed. Alternative line constructions can be selected from the drop-down menu in the DRO window.

Lines constructed from two lines

Up to three line constructions can be made from two lines:

- Midline 1:
Bisects the acute angle between the two lines
- Midline 2:
Bisects the obtuse angle between the two lines
- Gage line:
The line of a specified length perpendicular to bisector 1
(The user will be prompted for the length)

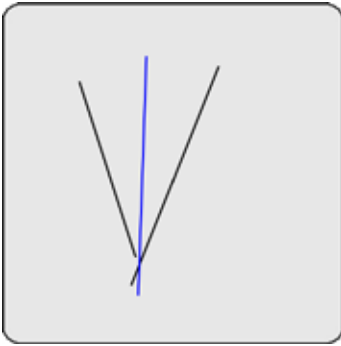

Midline 1

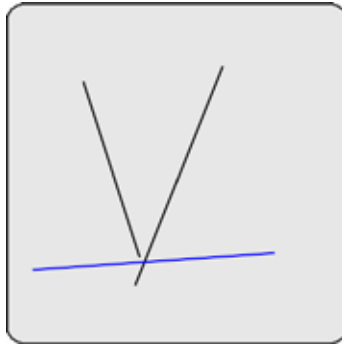

Midline 2

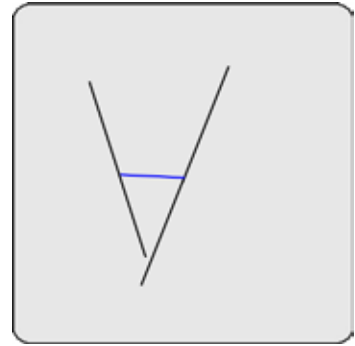

Gage line

To construct a line from two lines:

- 1 Touch the Measure line icon
- 2 Touch the first line feature
- 3 Press the Enter key
- 4 Touch the second line feature
- 5 Press the Enter key
- 6 Press the Finish key

The bisector 1 line will be constructed. Alternative line constructions can be selected from the drop-down menu in the DRO window.

Line constructed from a line and a distance

A line feature will be constructed and offset from a parent line feature by a parent distance feature.

To construct a line from a line and a distance:

- 1 Touch the Measure Line icon
- 2 Touch the line feature
- 3 Press the Enter key
- 4 Touch the distance feature
- 5 Press the Enter key
- 6 Press the Finish key

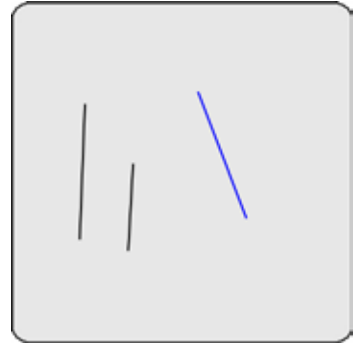

An offset line feature will be constructed.

Lines constructed from a line and a circle

Two line constructions can be made from a line and a circle:

- Perpendicular line:
The line from the center of the circle, to the line, perpendicular to the line
- Parallel line:
The line through the center of the circle, parallel to the line

To construct a line from a line and a circle:

- 1 Touch the Measure Line icon
- 2 Touch the line feature
- 3 Press the Enter key
- 4 Touch the circle feature
- 5 Press the Enter key
- 6 Press the Finish key

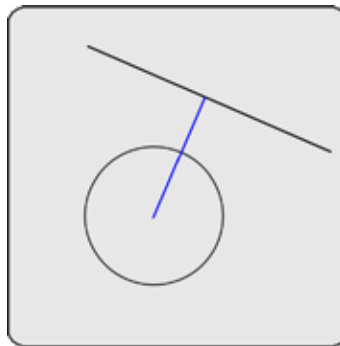

Perpendicular line

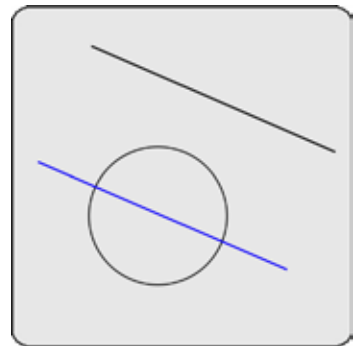

Parallel line

The perpendicular line will be constructed. Alternative line constructions can be selected from the drop-down menu in the DRO window.

Lines constructed from a line and a slot

Two line constructions can be made from a line and a slot:

- Perpendicular line:
The line from the center of the slot, to the line, perpendicular to the line
- Parallel line:
The line through the center of the slot, parallel to the line

To construct a line from a line and a slot:

- 1 Touch the Measure Line icon
- 2 Touch the line feature
- 3 Press the Enter key
- 4 Touch the slot feature
- 5 Press the Enter key
- 6 Press the Finish key

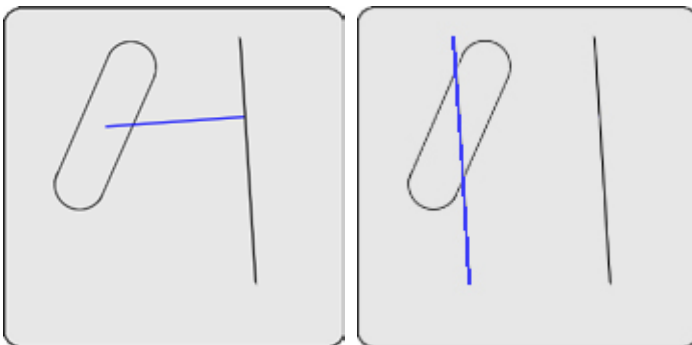

The perpendicular line will be constructed. The alternative parallel line construction can be selected from the drop-down menu in the DRO window.

Lines constructed from a line and an arc

Two line constructions can be made from a line and an arc:

- Perpendicular line:
The line from the center of the arc, to the line, perpendicular to the line
- Parallel line:
The line through the center of the arc, parallel to the line

To construct a line from a line and a arc:

- 1 Touch the Measure Line icon
- 2 Touch the line feature
- 3 Press the Enter key
- 4 Touch the arc feature
- 5 Press the Enter key
- 6 Press the Finish key

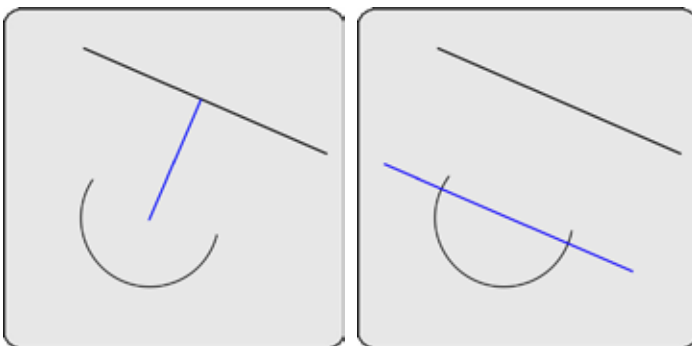

The perpendicular line will be constructed. The alternative parallel line construction can be selected from the drop-down menu in the DRO window.

Line constructed from a line and an angle

The line will be constructed and rotated counterclockwise the amount equal to the parent angle.

To construct a line from a line and an angle:

- 1 Touch the Measure Line icon
- 2 Touch the line feature
- 3 Press the Enter key
- 4 Touch the angle feature
- 5 Press the Enter key
- 6 Press the Finish key

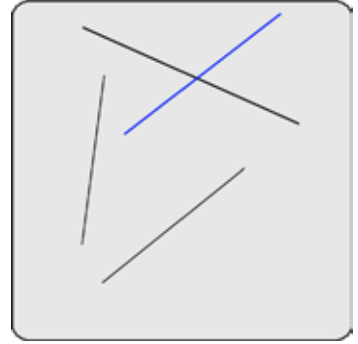

The rotated line will be constructed.

Lines constructed from a line and a rectangle

Two line constructions can be made from a line and a slot:

- Perpendicular line:
The line from the center of the slot, to the line, perpendicular to the line
- Parallel line:
The line through the center of the slot, parallel to the line

To construct a line from a line and a slot:

- 1 Touch the Measure Line icon
- 2 Touch the line feature
- 3 Press the Enter key
- 4 Touch the slot feature
- 5 Press the Enter key
- 6 Press the Finish key

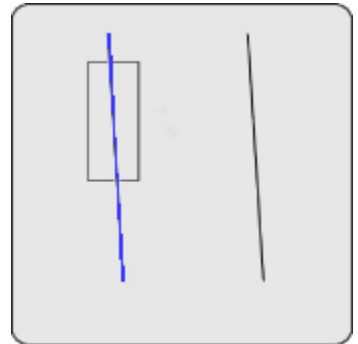
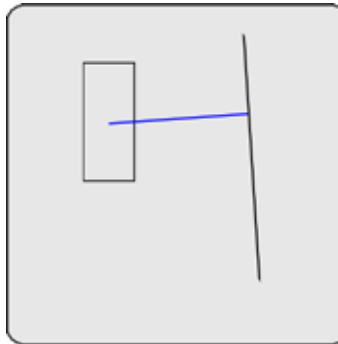

The perpendicular line will be constructed. The alternative parallel line construction can be selected from the drop-down menu in the DRO window.

Lines constructed from two circles

Up to three line constructions can be made from two circles:

- Two point line:
The line between the two circle centers
- Tangent line 1:
The first line tangent to both circles on the same side
- Tangent line 2:
The second line tangent to both circles on the opposite side

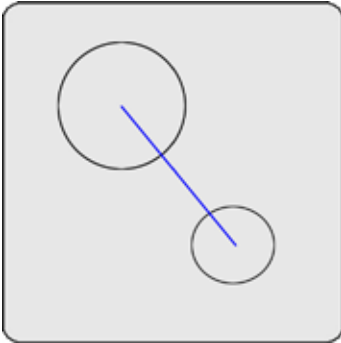

Two point line

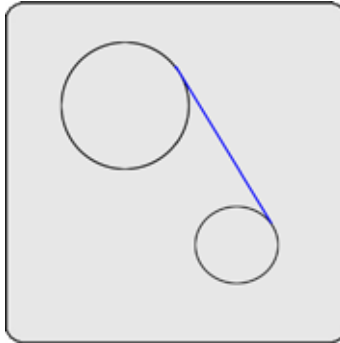

Tangent line 1

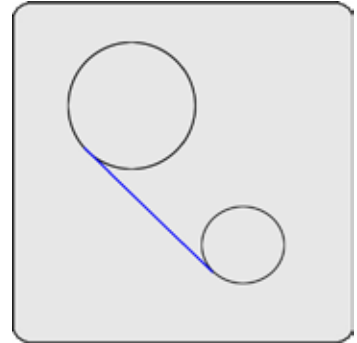

Tangent line 2

To construct a line between two circles:

- 1 Touch the Measure line icon
- 2 Touch the first circle feature
- 3 Press the Enter key
- 4 Touch the second circle feature
- 5 Press the Enter key
- 6 Press the Finish key

The two point line will be constructed. Alternative line constructions can be selected from the drop-down menu in the DRO window.

Lines constructed from a circle and an arc

Up to three line constructions can be made from a circle to an arc:

- Two point line:
The line between the circle and arc centers
- Tangent line 1:
The first line tangent to the circle and arc on the same side
- Tangent line 2:
The second line tangent to the circle and arc on the opposite side

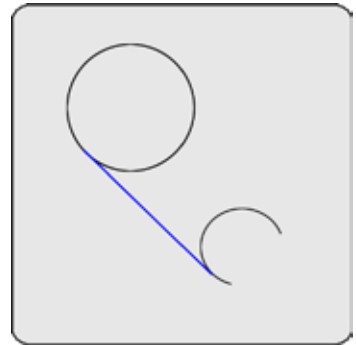
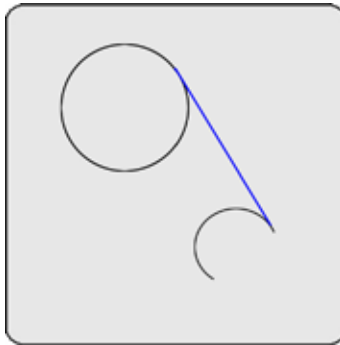
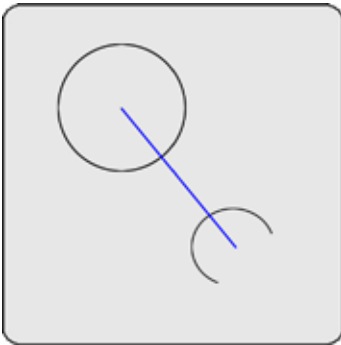

To construct a line between a circle and an arc:

- 1 Touch the Measure line icon
- 2 Touch the circle feature
- 3 Press the Enter key
- 4 Touch the arc feature
- 5 Press the Enter key
- 6 Press the Finish key

The two point line will be constructed. Alternative line constructions can be selected from the drop-down menu in the DRO window.

Lines constructed from a circle and a slot

Up to three line constructions can be made from a slot to a circle:

- Two point line:
The line between the slot and circle centers
- Tangent line 1:
The first line tangent to the slot and circle on the same side
- Tangent line 2:
The second line tangent to the slot and circle on the opposite side

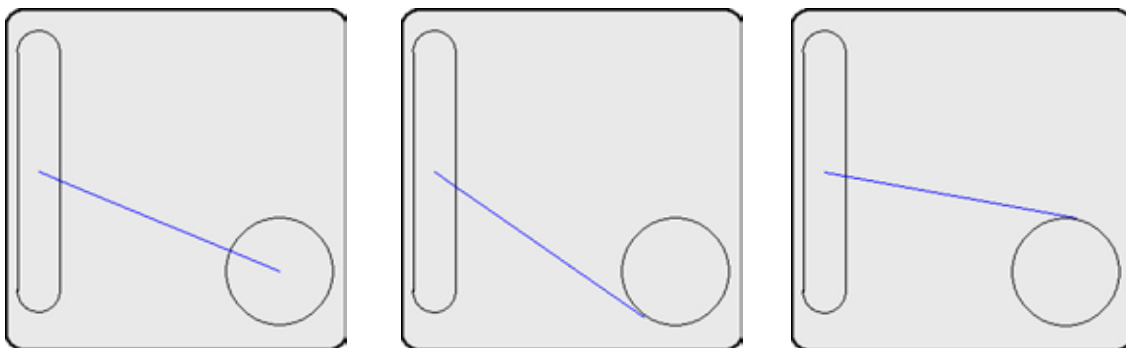

To construct a line from a slot and a circle:

- 1 Touch the Measure Line icon
- 2 Touch the circle feature
- 3 Press the Enter key
- 4 Touch the slot feature
- 5 Press the Enter key
- 6 Press the Finish key

The two point line will be constructed. Alternative line constructions can be selected from the drop-down menu in the DRO window.

Line constructed from a slot

The line feature will be constructed from the arc center at one end of the slot to the arc center at the other end.

To construct a line from a slot:

- 1 Touch the Measure Line icon
- 2 Touch the slot feature
- 3 Press the Enter key
- 4 Press the Finish key

The extracted line of the slot will be constructed.

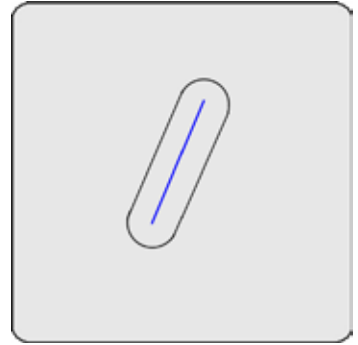
**Line constructed from two slots**

The line feature will be constructed from the center of one slot to the center of the other.

To construct a line from two slots:

- 1 Touch the Measure Line icon
- 2 Touch the first slot feature
- 3 Press the Enter key
- 4 Touch the second slot feature
- 5 Press the Enter key
- 6 Press the Finish key

The line will be constructed between the two slots.

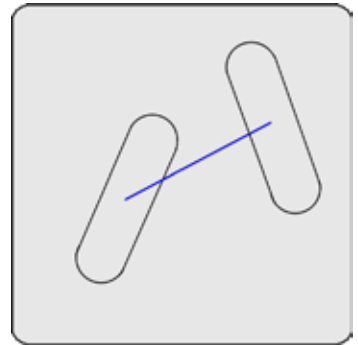

Lines constructed from a rectangle and a circle

Up to three line constructions can be made from a rectangle to a circle:

- Two point line:
The line between the rectangle and circle centers
- Tangent line 1:
The first line tangent to the rectangle and circle on the same side
- Tangent line 2:
The second line tangent to the rectangle and circle on the opposite side

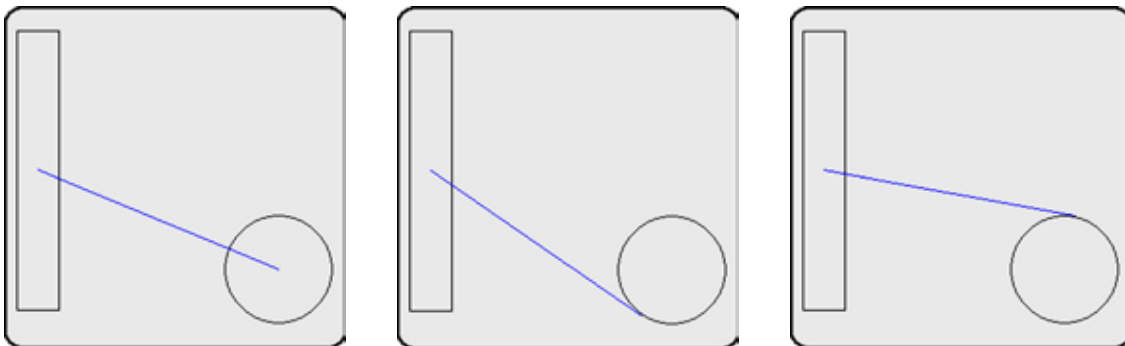

To construct a line from a rectangle and a circle:

- 1 Touch the Measure Line icon
- 2 Touch the rectangle feature
- 3 Press the Enter key
- 4 Touch the circle feature
- 5 Press the Enter key
- 6 Press the Finish key

The two point line will be constructed. Alternative line constructions can be selected from the drop-down menu in the DRO window.

Lines constructed from a slot and an arc

Up to three line constructions can be made from a slot to an arc:

- Two point line:
The line between the slot and arc centers
- Tangent line 1:
The first line tangent to the slot and arc on the same side
- Tangent line 2:
The second line tangent to the slot and arc on the opposite side

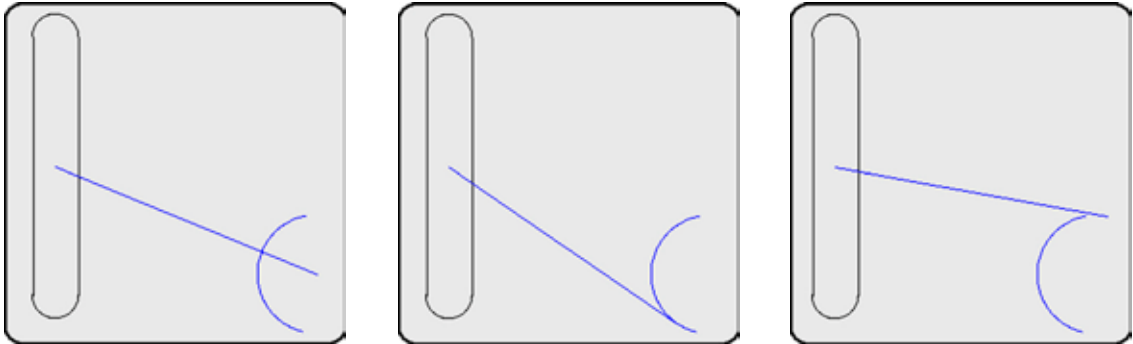

To construct a line from a slot and an arc:

- 1 Touch the Measure Line icon
- 2 Touch the slot feature
- 3 Press the Enter key
- 4 Touch the arc feature
- 5 Press the Enter key
- 6 Press the Finish key

The two point line will be constructed. Alternative line constructions can be selected from the drop-down menu in the DRO window.

Lines constructed from a rectangle and an arc

Up to three line constructions can be made from a rectangle to an arc:

- Two point line:
The line between the rectangle and arc centers
- Tangent line 1:
The first line tangent to the rectangle and arc on the same side
- Tangent line 2:
The second line tangent to the rectangle and arc on the opposite side

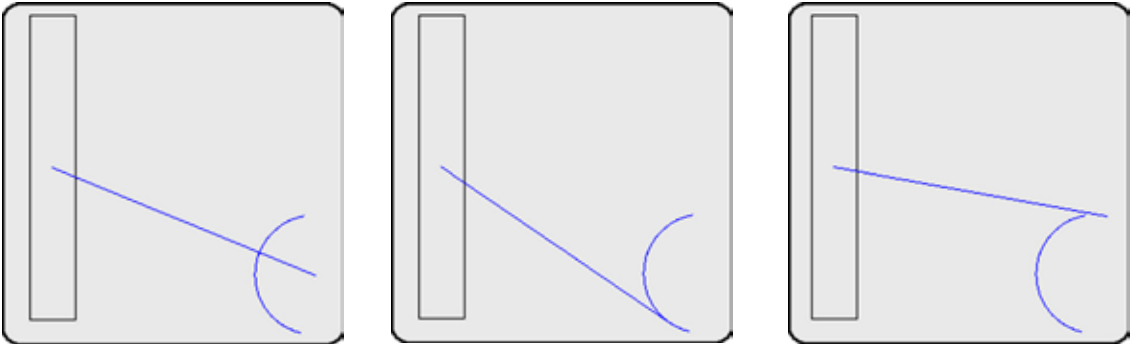

To construct a line from a rectangle and an arc:

- 1 Touch the Measure Line icon
- 2 Touch the rectangle feature
- 3 Press the Enter key
- 4 Touch the arc feature
- 5 Press the Enter key
- 6 Press the Finish key

The two point line will be constructed. Alternative line constructions can be selected from the drop-down menu in the DRO window.

Lines constructed from a slot and a rectangle

The line feature will be constructed from the center of the slot to the center of the rectangle.

To construct a line from a slot and a rectangle:

- 1 Touch the Measure Line icon
- 2 Touch the slot feature
- 3 Press the Enter key
- 4 Touch the rectangle feature
- 5 Press the Enter key
- 6 Press the Finish key

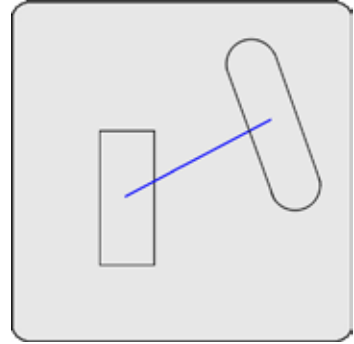

The two point line will be constructed.

Lines constructed between two rectangles

The line feature will be constructed from the center of one rectangle to the center of the other.

To construct a line between two rectangles:

- 1 Touch the Measure Line icon
- 2 Touch the first rectangle feature
- 3 Press the Enter key
- 4 Touch the second rectangle feature
- 5 Press the Enter key
- 6 Press the Finish key

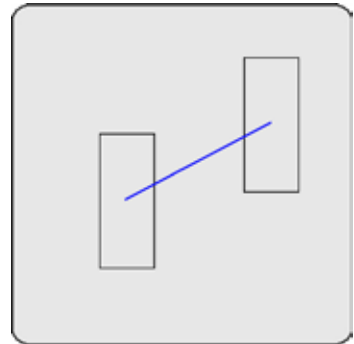

The two point line will be constructed.

Line constructed from two arcs

Up to three line constructions can be made from two arcs:

- Two point line:
The line between the two arc centers
- Tangent line 1:
The first line tangent to both arcs on the same side
- Tangent line 2:
The second line tangent to both arcs on the opposite side

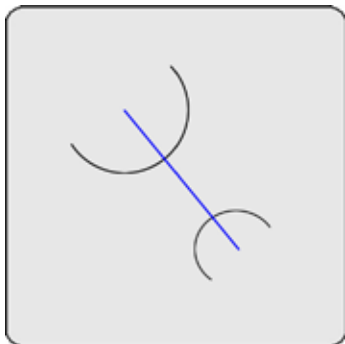

Two point line

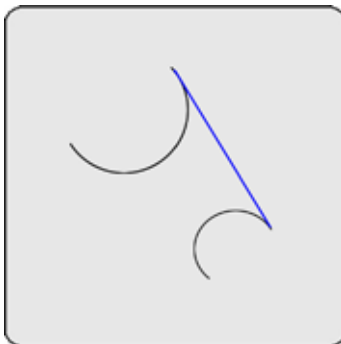

Tangent line 1

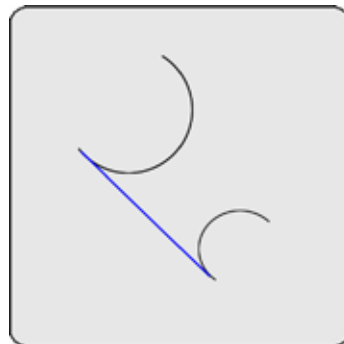

Tangent line 2

To construct a line between two arcs:

- 1 Touch the Measure Line icon
- 2 Touch the first arc feature
- 3 Press the Enter key
- 4 Touch the second arc feature
- 5 Press the Enter key
- 6 Press the Finish key

The two point line will be constructed. Alternative line constructions can be selected from the drop-down menu in the DRO window.

Line constructed from a rectangle

The line feature will be constructed from the radius center at one end of the rectangle to the radius center at the other end.

To construct a line from a slot:

- 1 Touch the Measure Line icon
- 2 Touch the rectangle feature
- 3 Press the Enter key
- 4 Press the Finish key

The center line of the rectangle will be constructed.

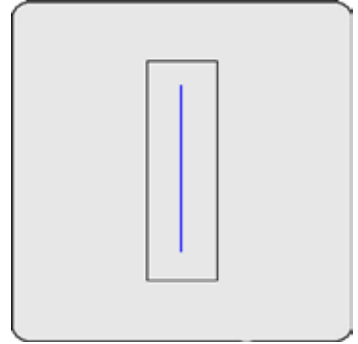
**Line constructed from multiple features**

The best fit line through the center of multiple features can be constructed from any combination and any number of points, slots, circles, and arcs.

To construct a line from multiple features:

- 1 Touch the Measure Line icon
- 2 Touch a feature
- 3 Press the Enter key
- 4 Repeat steps 2 and 3 for all features
- 5 Press the Finish key

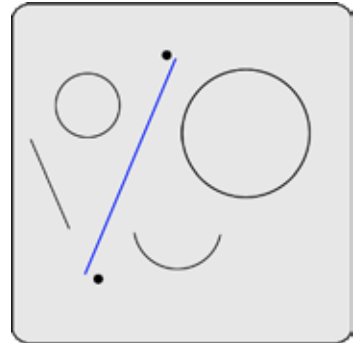

The best fit line through the entire collection of features will be constructed.

Distance constructions

Distances can be constructed from:

- Points
- Lines
- Distances
- Circles
- Arcs
- Slots

Distance constructed from a distance

A duplicate feature can be useful when it becomes desirable to perform new operations with the original while retaining a copy. To construct a distance from an existing distance:

- 1 Touch the Measure Distance icon
- 2 Touch the desired distance
- 3 Press the Enter key
- 4 Press the Finish key

The new distance feature will be constructed over the original distance.

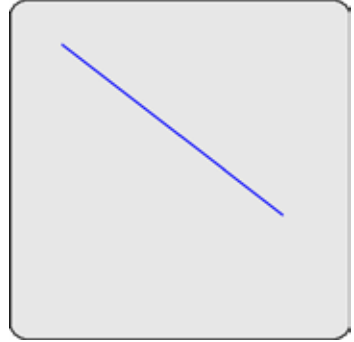

Distances constructed from two points

The distance feature will be constructed between the two points.

To construct a distance from two points:

- 1 Touch the Measure Distance icon
- 2 Touch the first point Feature
- 3 Press the Enter key
- 4 Touch the second point Feature
- 5 Press the Enter key
- 6 Press the Finish key

The new distance feature will be constructed between the two points.

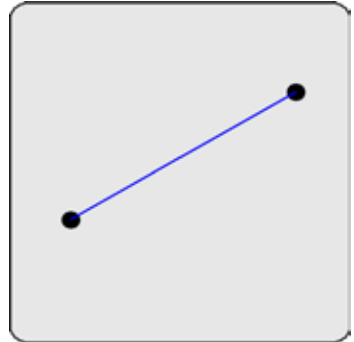

Distances constructed from a point and a line

The distance feature will be constructed from the point to the line perpendicular to the line, or perpendicular to the extended virtual line if the line feature is short.

To construct a distance from a point and a line:

- 1 Touch the Measure Distance icon
- 2 Touch the point feature
- 3 Press the Enter key
- 4 Touch the line feature
- 5 Press the Enter key
- 6 Press the Finish key

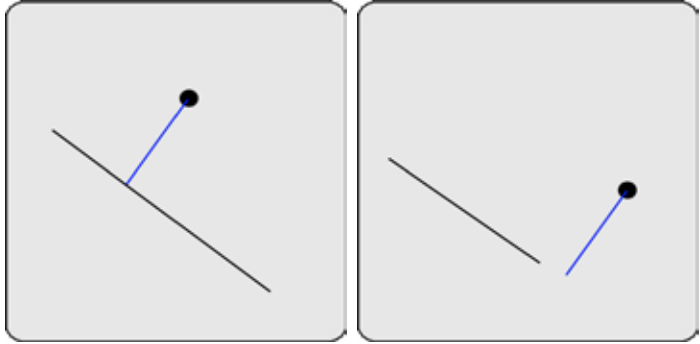

The new distance feature will be constructed.

Distances constructed from a point and a rectangle

The distance feature will be constructed from the point to the center of the rectangle.

To construct a distance from a point and a rectangle:

- 1 Touch the Measure Distance icon
- 2 Touch the point feature
- 3 Press the Enter key
- 4 Touch the rectangle feature
- 5 Press the Enter key
- 6 Press the Finish key

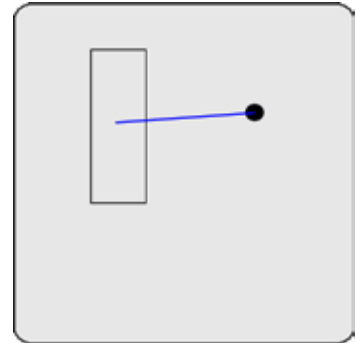

The new distance feature will be constructed.

Distances constructed from a point and a circle

Up to three distance constructions can be made from a point to a circle:

- Distance between features:
The distance between the point and circle center
- Nearest distance:
The distance between the point and nearest circle circumference
- Farthest distance:
The distance between the point and farthest circle circumference

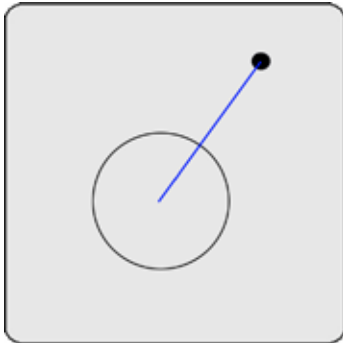

Distance between features

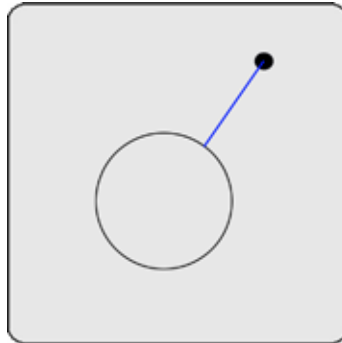

Nearest distance

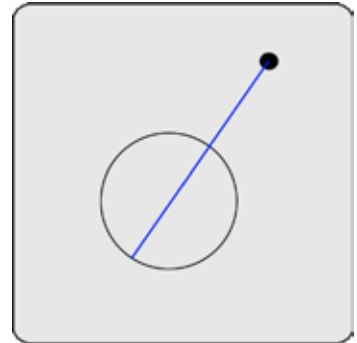

Farthest distance

To construct a distance between a point and a circle:

- 1 Touch the Measure Distance icon
- 2 Touch the point feature
- 3 Press the Enter key
- 4 Touch the circle feature
- 5 Press the Enter key
- 6 Press the Finish key

The distance between the point and circle center will be constructed. Alternative distance constructions can be selected from the drop-down menu in the DRO window.

Distance constructed from a point and a slot

The distance feature will be constructed between the point and the center of the slot.

To construct a distance from a point to a slot:

- 1 Touch the Measure Distance icon
- 2 Touch the point Feature
- 3 Press the Enter key
- 4 Touch the slot Feature
- 5 Press the Enter key
- 6 Press the Finish key

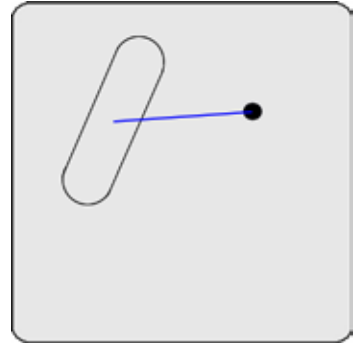

The new distance feature will be constructed between the point and the slot.

Distances constructed from a point and an arc

Up to three distance constructions can be made from a point to an arc:

- Distance between features:
The distance between the point and arc center
- Nearest distance:
The distance between the point and nearest arc circumference
- Farthest distance:
The distance between the point and farthest arc circumference

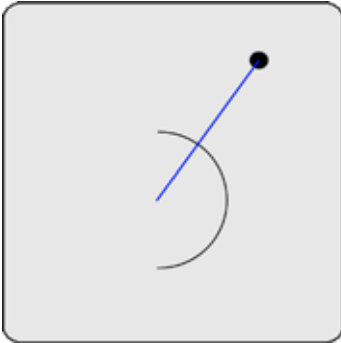

Distance between features

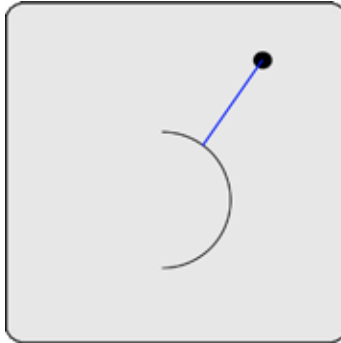

Nearest distance

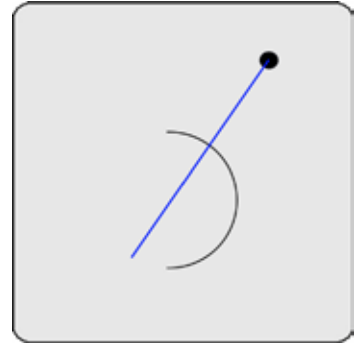

Farthest distance

To construct a distance between a point and a arc:

- 1 Touch the Measure Distance icon
- 2 Touch the point feature
- 3 Press the Enter key
- 4 Touch the arc feature
- 5 Press the Enter key
- 6 Press the Finish key

The distance between the point and arc center will be constructed. Alternative distance constructions can be selected from the drop-down menu in the DRO window.

Distance constructed from a line

The length-of-axis distance feature will be constructed from a parent line feature.

To construct a distance from a line:

- 1 Touch the Measure Distance icon
- 2 Touch the line Feature
- 3 Press the Enter key
- 4 Press the Finish key

The new distance feature will be constructed over the line.

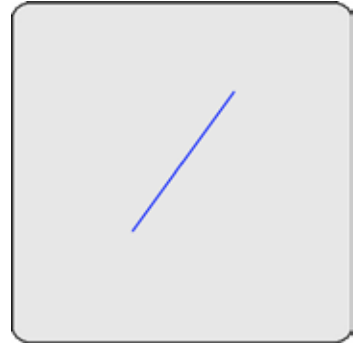
**Distance constructed from a line and a rectangle**

The distance feature will be constructed between the center of the line and the center of the rectangle.

To construct a distance from a line to a rectangle:

- 1 Touch the Measure Distance icon
- 2 Touch the line Feature
- 3 Press the Enter key
- 4 Touch the rectangle Feature
- 5 Press the Enter key
- 6 Press the Finish key

The new distance feature will be constructed between the two centers.

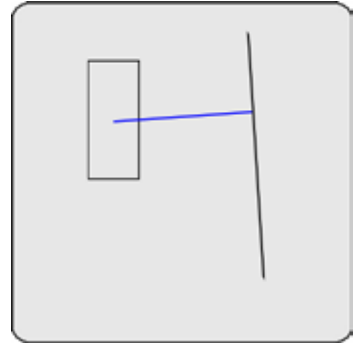

Distances constructed from two lines

Up to three distance constructions can be made from two lines:

- Center distance:
The perpendicular distance from the first line in the features list to the center of the second
- Min distance:
The perpendicular distance from the first line in the features list to the nearest point of the second
- Max distance:
The perpendicular distance from the first line in the features list to the farthest point of the second

Distances from virtual line extensions will be shown if the first line in the features list is not long.

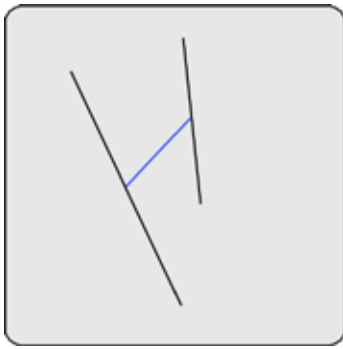

Center distance

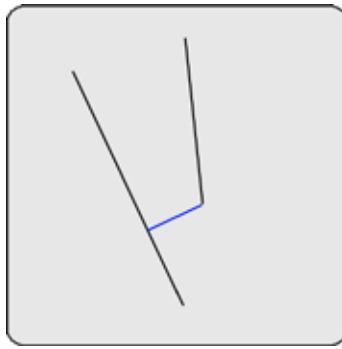

Min distance

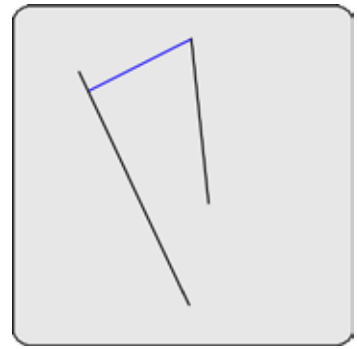

Max distance

To construct a distance between two lines:

- 1 Touch the Measure Distance icon
- 2 Touch the first line feature
- 3 Press the Enter key
- 4 Touch the second line feature
- 5 Press the Enter key
- 6 Press the Finish key

The center distance will be constructed. Alternative distance constructions can be selected from the drop-down menu in the DRO window.

Distances constructed from a line and a circle

Up to three distance constructions can be made from a line and a circle:

- Center distance:
The perpendicular distance from the line to the center of the circle
- Min distance:
The perpendicular distance from the line to the nearest point of the circle
- Max distance:
The perpendicular distance from the line to the farthest point of the circle

Distances from virtual line extensions will be shown if the line is not long.

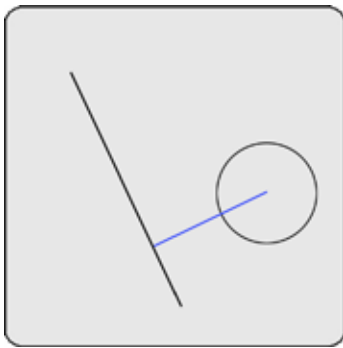

Center distance

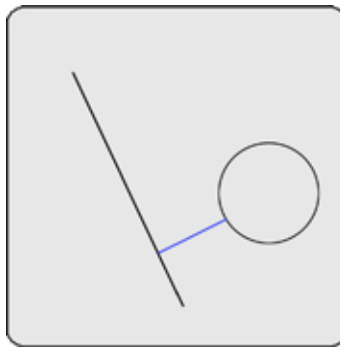

Min distance

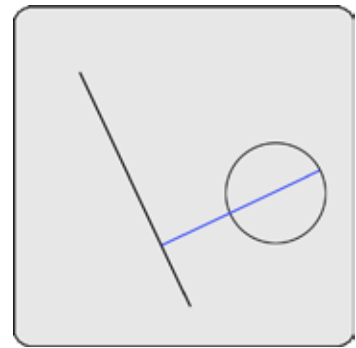

Max distance

To construct a distance between a line and a circle:

- 1 Touch the Measure Distance icon
- 2 Touch the line feature
- 3 Press the Enter key
- 4 Touch the circle feature
- 5 Press the Enter key
- 6 Press the Finish key

The center distance will be constructed. Alternative distance constructions can be selected from the drop-down menu in the DRO window.

Distances constructed from a line and an arc

Up to three distance constructions can be made from a line and an arc:

- Center distance:
The perpendicular distance from the line to the center of the arc
- Min distance:
The perpendicular distance from the line to the nearest point of the arc
- Max distance:
The perpendicular distance from the line to the farthest point of the arc

Distances from virtual line extensions will be shown if the line is not long.

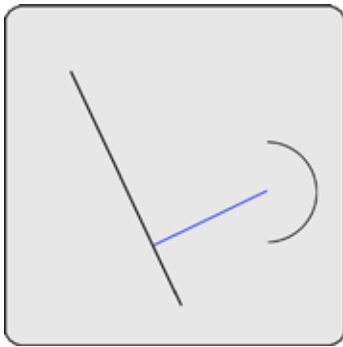

Center distance

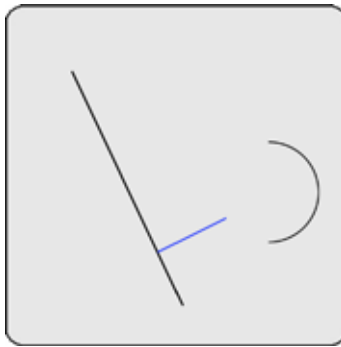

Min distance

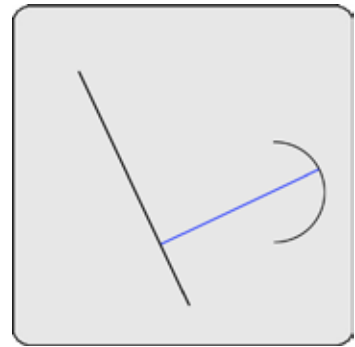

Max distance

To construct the distance between a line and an arc:

- 1 Touch the Measure Distance icon
- 2 Touch the line feature
- 3 Press the Enter key
- 4 Touch the arc feature
- 5 Press the Enter key
- 6 Press the Finish key

The center distance will be constructed. Alternative distance constructions can be selected from the drop-down menu in the DRO window.

Distance constructed from a line and a slot

The distance feature will be constructed from the center of the slot perpendicular to the line.

To construct a distance from a line and a slot:

- 1 Touch the Measure Distance icon
- 2 Touch the line Feature
- 3 Press the Enter key
- 4 Touch the slot Feature
- 5 Press the Enter key
- 6 Press the Finish key

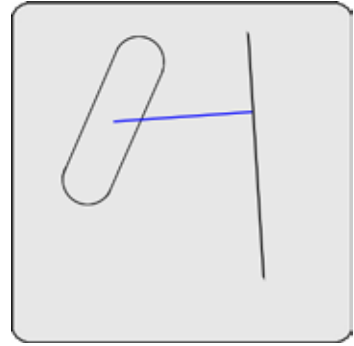

The distance feature will be constructed between the line and slot. Distances from virtual line extensions will be shown if the line is not long.

Distance constructed from two distances

The sum-of-distances feature will be constructed from two distance features.

To construct a distance from two distance features:

- 1 Touch the Measure Distance icon
- 2 Touch the first distance Feature
- 3 Press the Enter key
- 4 Touch the second distance Feature
- 5 Press the Enter key
- 6 Press the Finish key

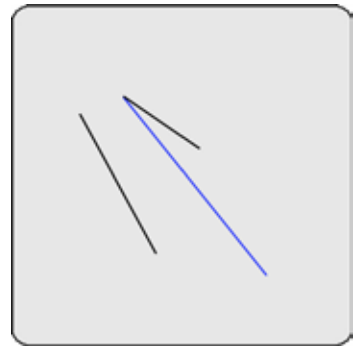

The distance feature will be constructed between the two distance features.

Distances constructed from two circles

Up to three distance constructions can be made from two circles:

- Center distance:
The distance from the center of one circle to the center of the other
- Min distance:
The minimum distance between the two circle circumferences
- Max distance:
The maximum distance between the two circle circumferences

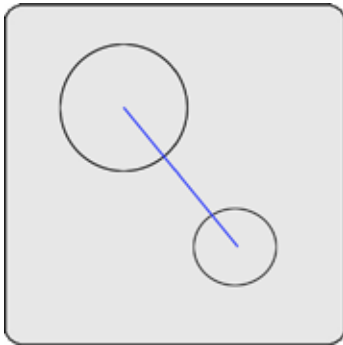

Center distance

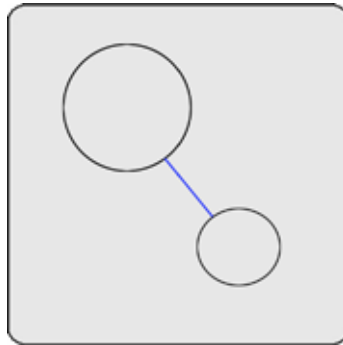

Min distance

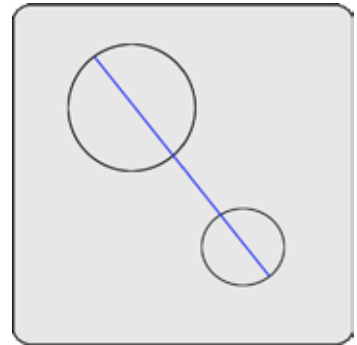

Max distance

To construct the distance between two circles:

- 1 Touch the Measure Distance icon
- 2 Touch the first circle feature
- 3 Press the Enter key
- 4 Touch the second circle feature
- 5 Press the Enter key
- 6 Press the Finish key

The center distance will be constructed. Alternative distance constructions can be selected from the drop-down menu in the DRO window.

Distances constructed from a slot and a circle

The distance feature will be constructed between the centers of the slot and the circle.

To construct a distance from a slot and a circle:

- 1 Touch the Measure Distance icon
- 2 Touch the slot Feature
- 3 Press the Enter key
- 4 Touch the circle Feature
- 5 Press the Enter key
- 6 Press the Finish key

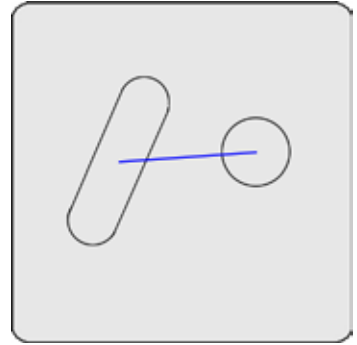

The distance feature will be constructed between the slot and the circle.

Distances constructed from a rectangle and a circle

The distance feature will be constructed between the centers of the rectangle and the circle.

To construct a distance from a rectangle and a circle:

- 1 Touch the Measure Distance icon
- 2 Touch the rectangle Feature
- 3 Press the Enter key
- 4 Touch the circle Feature
- 5 Press the Enter key
- 6 Press the Finish key

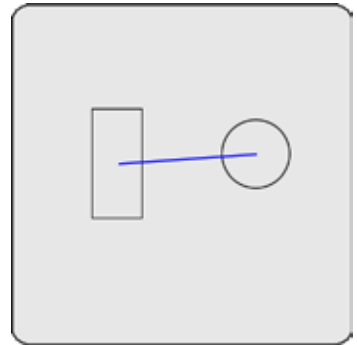

The distance feature will be constructed between the rectangle and the circle.

Distances constructed from an arc and a circle

Up to three distance constructions can be made from an arc and a circle:

- **Center distance:**
The distance from the center of the circle to the center of the arc
- **Min distance:**
The minimum distance between the arc and circle circumferences
- **Max distance:**
The maximum distance between the arc and circle circumferences

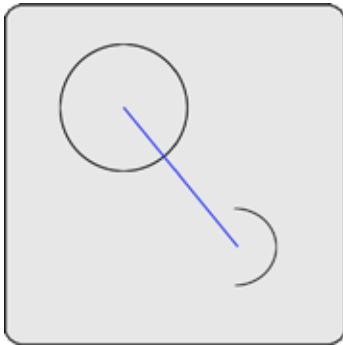

Center distance

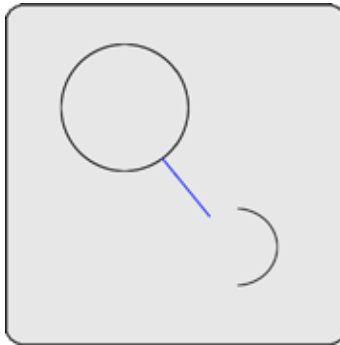

Min distance

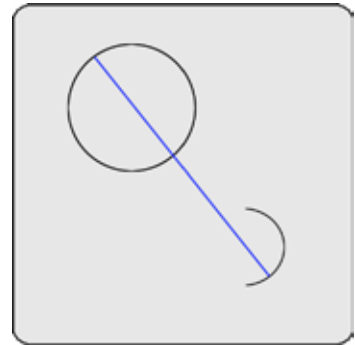

Max distance

To construct the distance between an arc and a circle:

- 1 Touch the Measure Distance icon
- 2 Touch the arc feature
- 3 Press the Enter key
- 4 Touch the circle feature
- 5 Press the Enter key
- 6 Press the Finish key

The center distance will be constructed. Alternative distance constructions can be selected from the drop-down menu in the DRO window.

Distance constructed from two slots

The distance feature will be constructed between the centers of two slots.

To construct a distance between two slots:

- 1 Touch the Measure Distance icon
- 2 Touch the first slot Feature
- 3 Press the Enter key
- 4 Touch the second slot Feature
- 5 Press the Enter key
- 6 Press the Finish key

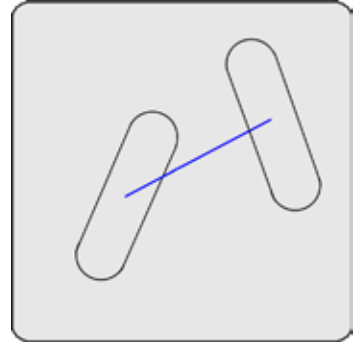

The distance feature will be constructed between the two slots.

Distances constructed from a slot and an arc

The distance feature will be constructed between the centers of the slot and the arc.

To construct a distance from a slot and an arc:

- 1 Touch the Measure Distance icon
- 2 Touch the slot Feature
- 3 Press the Enter key
- 4 Touch the arc Feature
- 5 Press the Enter key
- 6 Press the Finish key

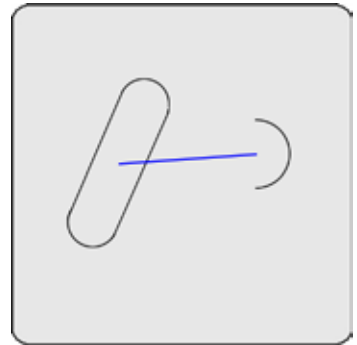

The distance feature will be constructed between the slot and the arc.

Distances constructed from a rectangle and an arc

The distance feature will be constructed between the centers of the rectangle and the arc.

To construct a distance from a rectangle and an arc:

- 1 Touch the Measure Distance icon
- 2 Touch the rectangle Feature
- 3 Press the Enter key
- 4 Touch the arc Feature
- 5 Press the Enter key
- 6 Press the Finish key

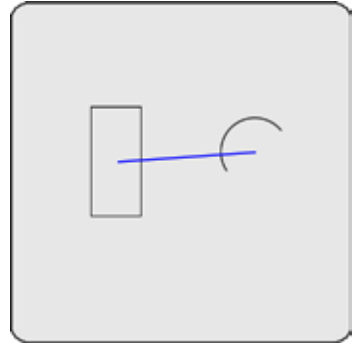

The distance feature will be constructed between the rectangle and the arc.

Distances constructed from a slot and a rectangle

The distance feature will be constructed between the centers of a slot and a rectangle.

To construct a distance from a slot and a rectangle:

- 1 Touch the Measure Distance icon
- 2 Touch the slot Feature
- 3 Press the Enter key
- 4 Touch the rectangle Feature
- 5 Press the Enter key
- 6 Press the Finish key

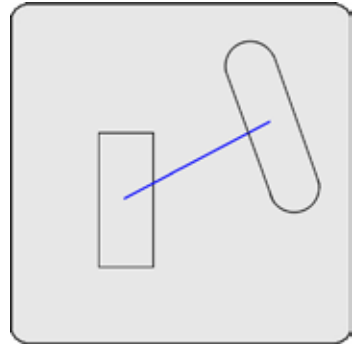

The distance feature will be constructed between the slot and the rectangle.

Distances constructed between two rectangles

The distance feature will be constructed between the centers of two rectangles.

To construct a distance between two rectangles:

- 1 Touch the Measure Distance icon
- 2 Touch the first rectangle Feature
- 3 Press the Enter key
- 4 Touch the second rectangle Feature
- 5 Press the Enter key
- 6 Press the Finish key

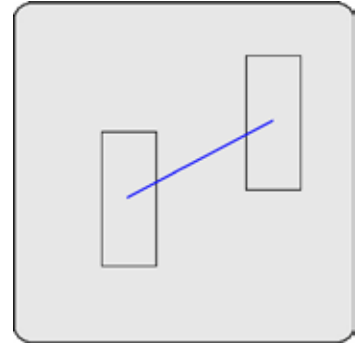

The distance feature will be constructed between the two rectangles.

Distances constructed from two arcs

Up to three different distance constructions can be made from two arcs:

- **Center distance:**
The distance from the center of one arc to the center of the other
- **Min distance:**
The minimum distance between the two arc circumferences
- **Max distance:**
The maximum distance between the two arc circumferences

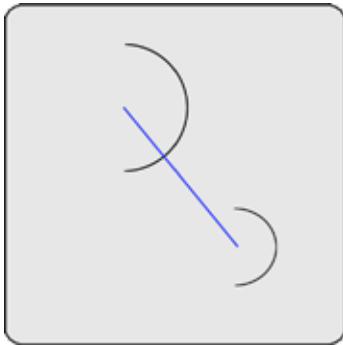

Center distance

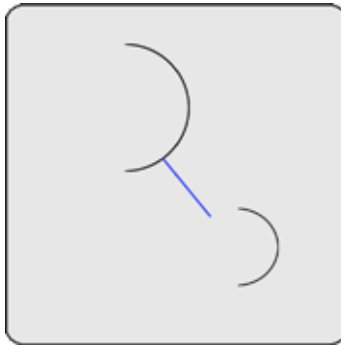

Min distance

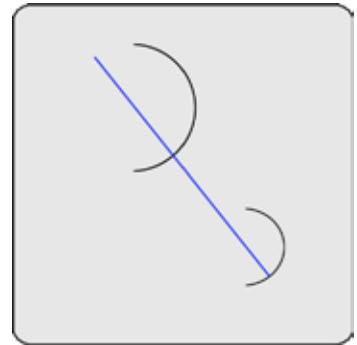

Max distance

To construct the distance between two arcs:

- 1 Touch the Measure Distance icon
- 2 Touch the first arc feature
- 3 Press the Enter key
- 4 Touch the second arc feature
- 5 Press the Enter key
- 6 Press the Finish key

The center distance will be constructed. Alternative distance constructions can be selected from the drop-down menu in the DRO window.

Circle constructions

Circles can be constructed from:

- Points
- Lines
- Circles
- Slots
- Distances
- Arcs

Circle constructed from a circle

A duplicate feature can be useful when it becomes desirable to perform new operations with the original while retaining a copy.

To construct a circle from an existing circle:

- 1 Touch the Measure Circle icon
- 2 Touch the desired circle
- 3 Press the Enter key
- 4 Press the Finish key

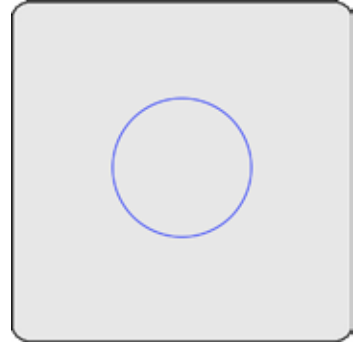

The new circle feature will be constructed over the original circle.

Circles constructed from two lines

A wire gage circle will be constructed between the two lines. The user will be prompted for the circle radius.

To construct a circle from two lines:

- 1 Touch the Measure Circle icon
- 2 Touch the first line feature
- 3 Press the Enter key
- 4 Touch the second line feature
- 5 Press the Enter key
- 6 Press the Finish key

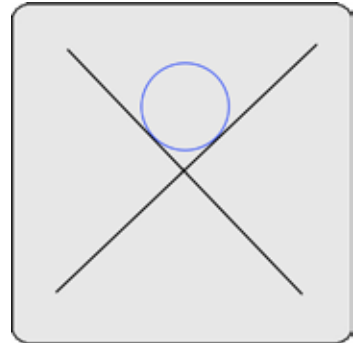

The wire gage circle will be constructed.

Circle constructed from a circle and a distance

An offset circle will be constructed from circle and distance parent features. A circle equal to the parent circle will be constructed, offset the amount equal to the parent distance.

To construct a circle from a circle and a distance:

- 1 Touch the Measure Circle icon
- 2 Touch the circle feature
- 3 Press the Enter key
- 4 Touch the distance feature
- 5 Press the Enter key
- 6 Press the Finish key

The offset circle will be constructed.

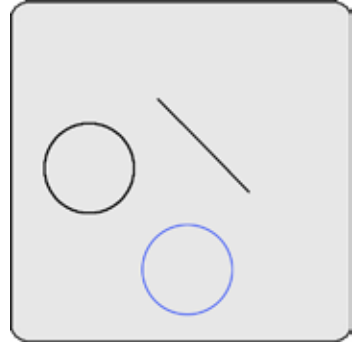
**Circle constructed from two circles**

The circle will be constructed as an average of the two parent positions and sizes.

To construct a circle from two circles:

- 1 Touch the Measure Circle icon
- 2 Touch the first circle feature
- 3 Press the Enter key
- 4 Touch the second circle feature
- 5 Press the Enter key
- 6 Press the Finish key

The average circle will be constructed.

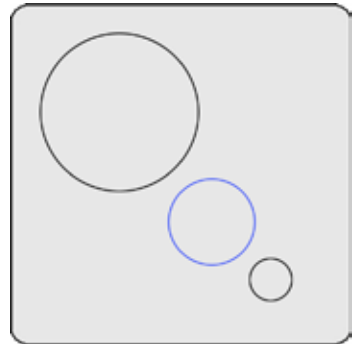

Circle constructed from multiple features

A circle feature can be constructed from any number of parent features. The parent features can be any combination of points, slots, rectangles, arcs and circles. The center points of the parent features will be used to construct the new circle feature. When more than three parent features are used, the circle can be constructed using the fitting algorithm of the user's choice.

To construct a circle from multiple features:

- 1 Touch the Measure Circle icon
- 2 Touch a feature
- 3 Press the Enter key
- 4 Repeat steps 2 and 3 for all features
- 5 Press the Finish key

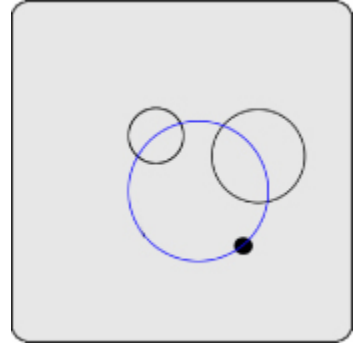

The best fit circle through the entire collection of features will be constructed.

Arc constructions

Arcs can be constructed from:

- Points
- Lines
- Circles
- Slots
- Distances
- Arcs

Arc constructed from an arc

A duplicate feature can be useful when it becomes desirable to perform new operations with the original while retaining a copy.

To construct an arc from an existing arc:

- 1 Touch the Measure Arc icon
- 2 Touch the desired arc
- 3 Press the Enter key
- 4 Press the Finish key

The new arc feature will be constructed over the original arc.

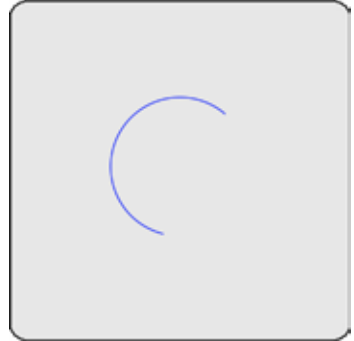

Arc constructed from an arc and a distance

An offset arc will be constructed from arc and distance parent features. An arc equal to the parent arc will be constructed, offset the amount equal to the parent distance.

To construct an arc from an arc and a distance:

- 1 Touch the Measure Arc icon
- 2 Touch the arc feature
- 3 Press the Enter key
- 4 Touch the distance feature
- 5 Press the Enter key
- 6 Press the Finish key

The offset arc will be constructed.

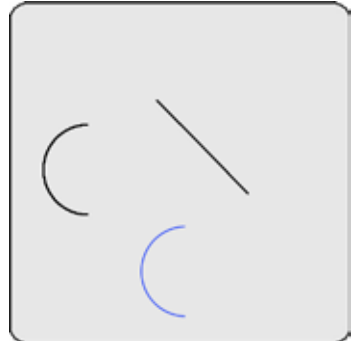

Angle constructions

Angles can be constructed from:

- An angle
- Two lines

Angle constructed from an angle

A duplicate feature can be useful when it becomes desirable to perform new operations with the original while retaining a copy.

To construct an angle from an existing angle:

- 1 Touch the Measure Angle icon
- 2 Touch the desired angle
- 3 Press the Enter key
- 4 Press the Finish key

The new angle feature will be constructed over the original angle.

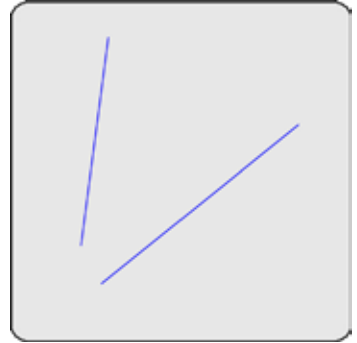

Angle constructed from two lines

Up to four angle constructions can be made from two lines:

- Interior angle:
The angle included between the lines
- 180 minus:
180 degrees minus the angle included between the lines
- 180 plus:
180 degrees plus the angle included between the lines
- 360 minus:
360 degrees minus the angle included between the lines

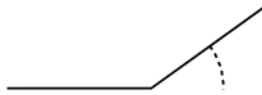
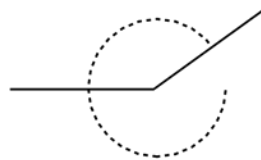
***Interior angle******180 minus******180 plus******360 minus***

To construct angles from two lines:

- 1 Touch the Measure Angle icon
- 2 Touch the first line feature
- 3 Press the Enter key
- 4 Touch the second line feature
- 5 Press the Enter key
- 6 Press the Finish key

The interior angle will be constructed. Alternative angle constructions can be selected from the drop-down menu in the DRO window.

Creating features

Features can be created by entering information that describes feature size and position. Information can be entered in metric or English units of measure.

The following feature types can be created:

- Points
- Lines
- Distances
- Rectangles
- Circles
- Arcs
- Slots

Creating a point

To create a point:

- 1 Touch the measure point icon, and then touch the data entry icon. The data entry box will be displayed.

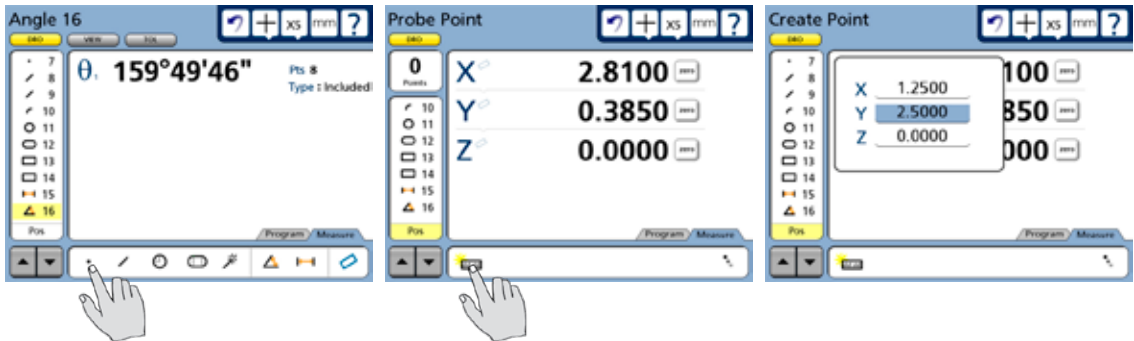

- 2 Enter the feature data in the fields provided and press Finish.

Creating a line

To create a line:

- 1 Touch the measure line icon, and then touch the data entry icon. The data entry box will be displayed.

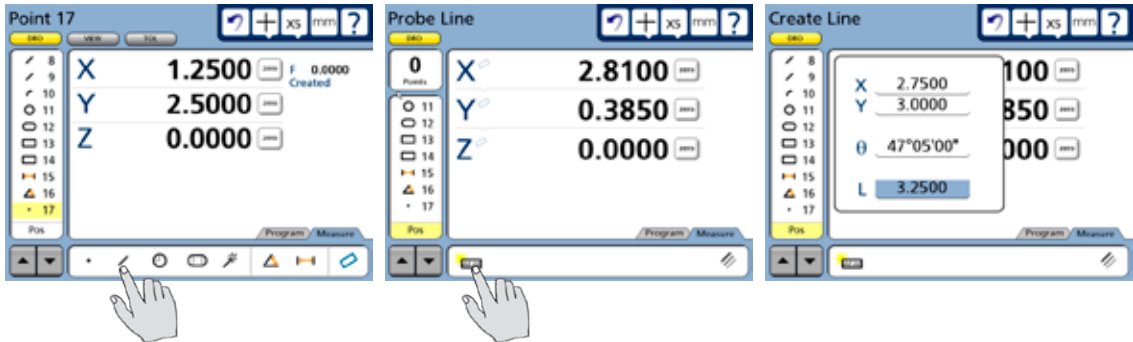

- 2 Enter the feature data in the fields provided and press Finish.

Creating a circle

To create a circle:

- 1 Touch the measure circle icon, and then touch the data entry icon. The data entry box will be displayed.

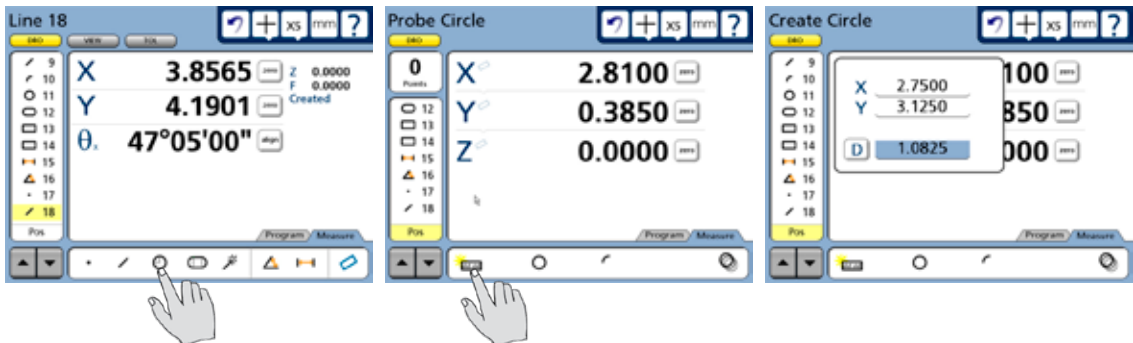

- 2 Enter the feature data in the fields provided and press Finish.

Creating an arc

To create an arc:

- 1 Touch the measure circle icon, the measure arc icon and then touch the data entry icon. The data entry box will be displayed.

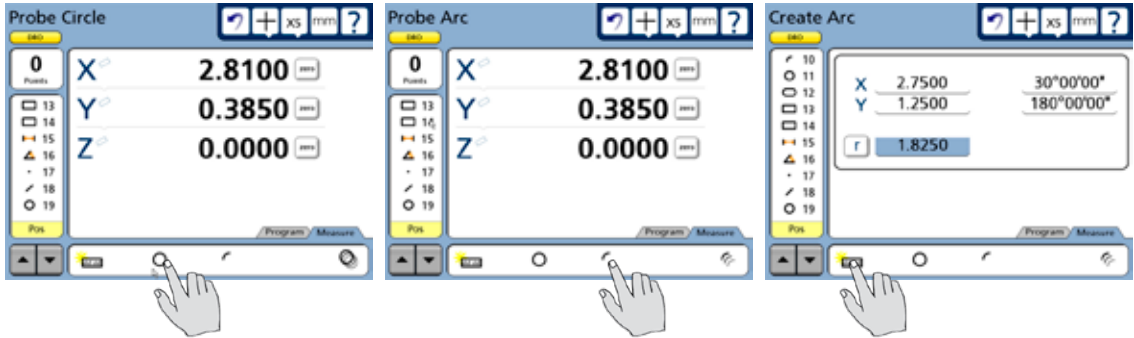

- 2 Enter the feature data in the fields provided and press Finish.

Creating a slot

To create a slot:

- 1 Touch the measure slot icon, and then touch the data entry icon. The data entry box will be displayed.

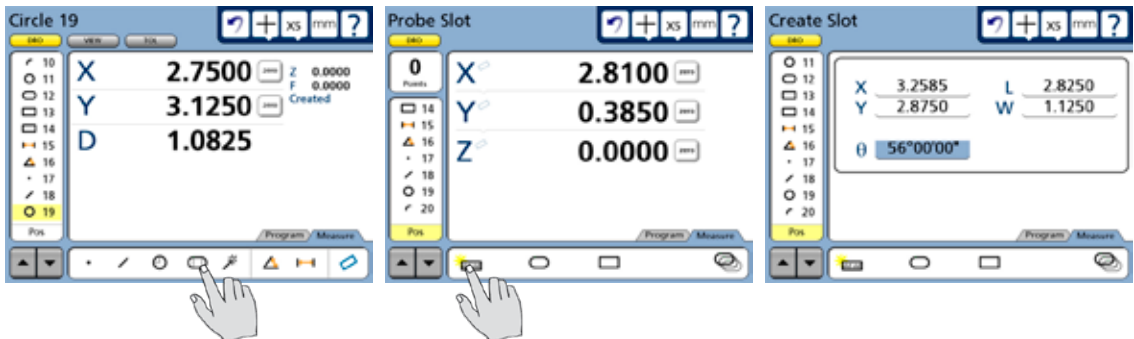

- 2 Enter the feature data in the fields provided and press Finish.

Creating a rectangle

To create a rectangle:

- 1 Touch the measure slot icon, the measure rectangle icon and then touch the data entry icon. The data entry box will be displayed.

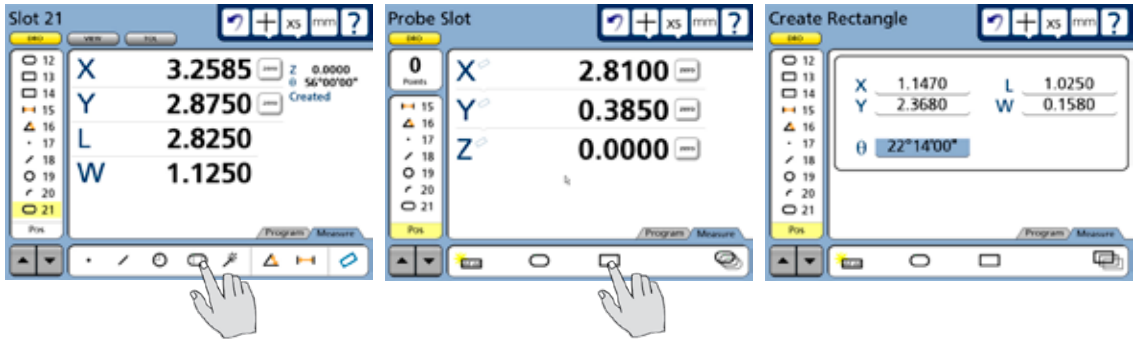

- 2 Enter the feature data in the fields provided and press Finish.

Chapter 7: Tolerancing

Tolerances can easily be applied to position, size, orientation, form, runout and concentricity measurements using the tools found in the tolerance screens.



CAUTION

Discrete point measuring machines estimate the size, position, orientation, and form of geometric features based on points probed. When parts are designed with critical tolerances, be sure that you have probed sufficient points to calculate a reliable estimate. For example, if you probe a circle with only three points, the circularity will be perfect and the circle will always pass a form tolerance test.



CAUTION

The QC-300 uses a best fit algorithm to estimate the size, position, orientation and form of geometric features. While the best fit yields very useful information, the results do not necessarily reflect how well the parts will fit together and perform their function. For example, a hole diameter could be calculated as 10.000 mm but have poor form. In this case, a 9.9 mm pin might not fit in the 10.000 mm hole.



NOTE

Tolerance calculations comply with the ASME Y14.5M-1994 standard except as noted in the tolerance section of Chapter 12: Reference Materials.

This chapter includes the following tolerance information:

Applying tolerances to features.....	127
Selecting a feature.....	127
Displaying the tolerance screen	127
Selecting a tolerance type	127
Selecting a specific tolerance.....	128
Entering nominal, limit or tolerance values.....	128
Omitting a tolerance category.....	129
Tolerance types	130
Bidirectional.....	130
True position.....	132
MMC.....	133
LMC	134
Runout.....	135
Roundness.....	135
Concentricity.....	135
Straightness	135
Parallelism.....	136
Perpendicularity	136
Angle.....	136
Width.....	137

Applying tolerances to features

Tolerances are applied to feature measurements using tolerance screens. The method of applying tolerances to features is diagrammed below and is nearly identical for all tolerance types.

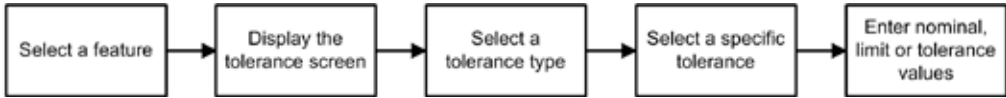

In the following example, a true position tolerance is applied to a circle feature.

Selecting a feature

Touch the desired feature in the feature list to select it.

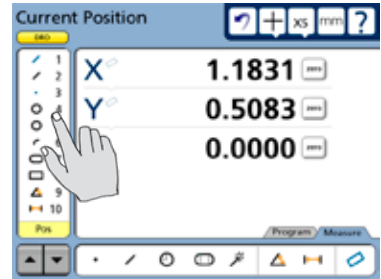

Displaying the tolerance screen

Touch the Tol screen button to display the tolerance screen.

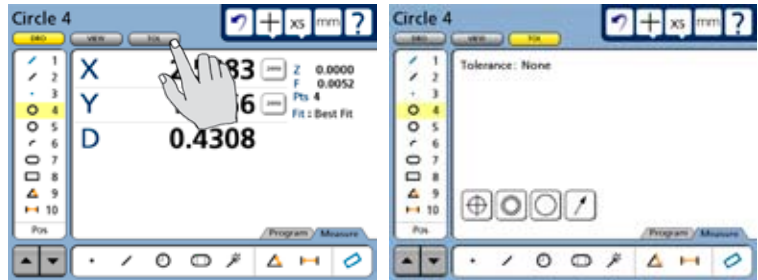

Selecting a tolerance type

Touch the desired tolerance type button to select a tolerance type. In this example, the position tolerance type is selected.

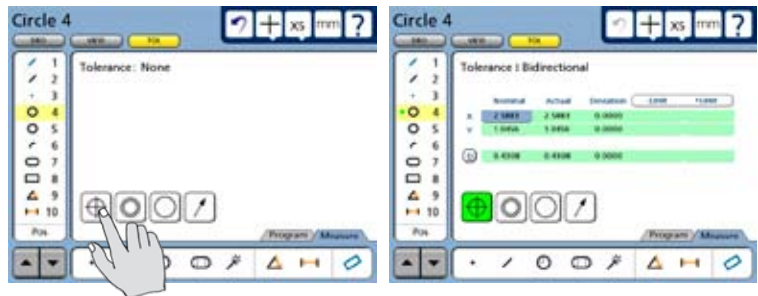

Selecting a specific tolerance

Touch the Tolerance menu title and then select the specific tolerance from the drop-down menu. The true position tolerance is selected in this example.

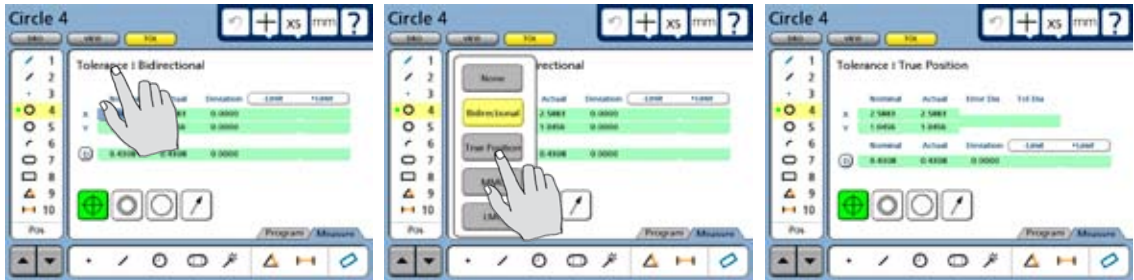

Entering nominal, limit or tolerance values

In this example, the Nominal and Tol Dia (Tolerance diameter around the nominal position) values are entered by touching the desired data fields and entering a new values using the number keys. Error and Deviation values are generated as soon as the Nominal and Tol Dia values are entered.

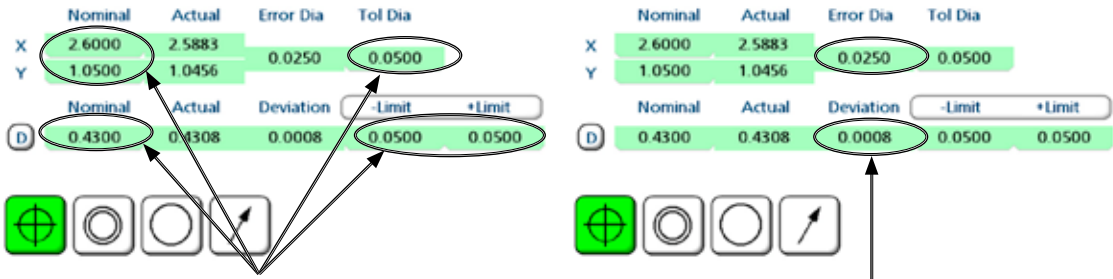



The Nominal, Tol Dia and Limit values are entered...

resulting in new error and deviation values

Pass/fail results are indicated by green and red colors in the tolerance screen and in the feature list. Pass is indicated by green, fail is indicated by red in the tolerance screen.

Any tolerance failure will be indicated by a red square next to the feature in the feature list. A green square will be displayed in the feature list when all tolerance tests pass.

Green square indicates pass →   4

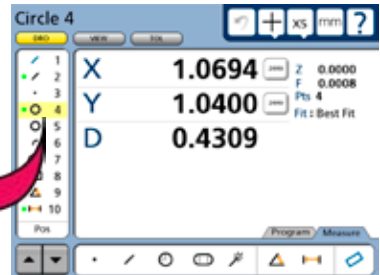

Omitting a tolerance category

When a tolerance category is unnecessary, it can be omitted. To omit a category, select the Nominal data field, remove any data by repeatedly pressing the Cancel key and press the Enter key. In this example, the Diameter category is omitted.

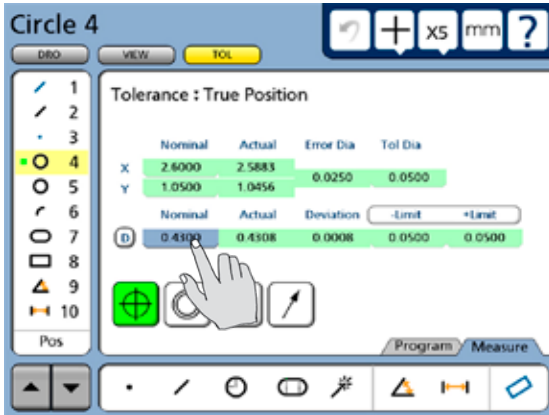

Touch the category to select a Nominal field...

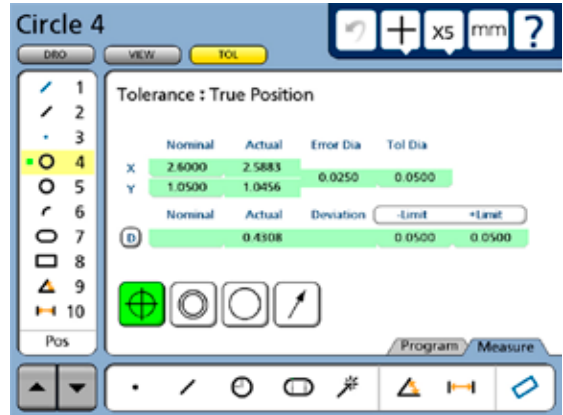

repeatedly press the Cancel key, then press Enter

Tolerance types

As mentioned earlier, the method of applying tolerances to features is nearly identical for all tolerances. This section describes the tolerance screen for each tolerance type. The following tolerances can be applied to feature measurements:

- Bidirectional
- True position
- MMC
- LMC
- Runout
- Roundness
- Concentricity
- Straightness
- Parallelism
- Perpendicularity
- Angle
- Width

Bidirectional

Bidirectional tolerances can be applied to points, lines, circles, arcs, slots and rectangles.

Points

The tolerance screen for points is used to specify the acceptable deviation from a nominal position in the X, Y and Z axes. The bidirectional tolerance compares the measured location of a point to the nominal location of the feature's center point.

Enter the nominal values into the X, Y and Z axis data fields provided. Enter the allowed limits into the Limit data fields as +/- ranges or as absolute limits. Touch the Limit data fields to toggle between +/- ranges or absolute limits.

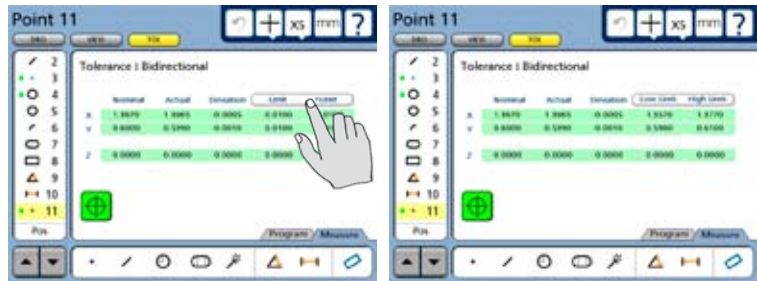

Lines

The tolerance screen for lines is used to specify the acceptable deviation from nominal positions in the X and Y axes. The bidirectional tolerance compares the measured location of the center point of a line to the nominal location of the line's center point.

Enter the nominal values into the X and Y axis data fields. Enter the allowed limits into the Limit data fields as +/- ranges or as absolute limits. Touch the Limit data fields to toggle between +/- ranges or absolute limits.

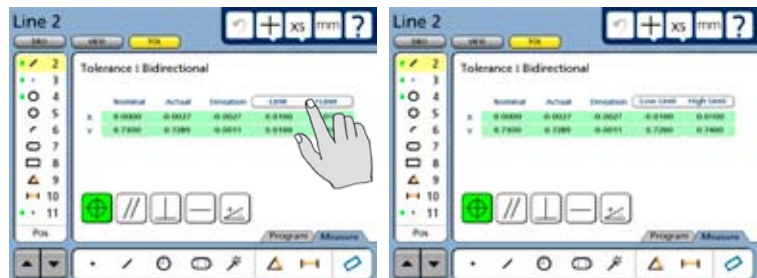

Circles and arcs

The tolerance screens for circles and arcs are identical, and are used to specify the acceptable deviation from nominal positions in the X and Y axes, and from the nominal diameter or radius. The bidirectional tolerance compares the measured location of the center point of the arc or circle to the nominal center point and compares the measured diameter or radius to the nominal. Touch the D (diameter) or r (radius) choice field in the DRO screen to toggle between the display of diameter and radius if desired.

Enter the nominal values into the X and Y axis and D (diameter) data fields provided. Enter the allowed limits into the Limit data fields as +/- ranges or as absolute limits. Touch the Limit data fields to toggle between +/- ranges or absolute limits.

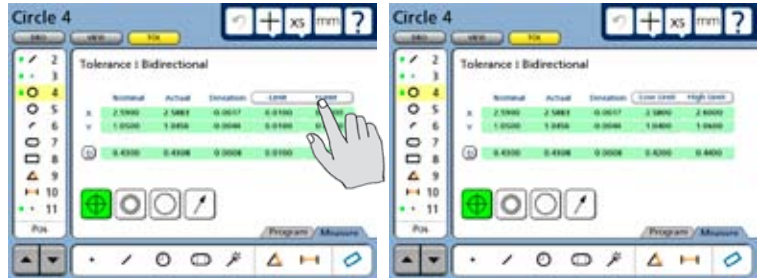

Slots and rectangles

The tolerance screens for slots and rectangles are identical and are used to specify the acceptable deviation from nominal positions in the X and Y axes, and from the nominal length and width. The bidirectional tolerance compares the measured location of the center point of the slot or rectangle to the nominal center point and compares the measured size to the nominal size.

Enter the nominal values into the X-Y axis and L-W data fields provided. Enter the allowed limits into the Limit data fields as +/- ranges or as absolute limits. Touch the Limit data fields to toggle between +/- ranges or absolute limits.

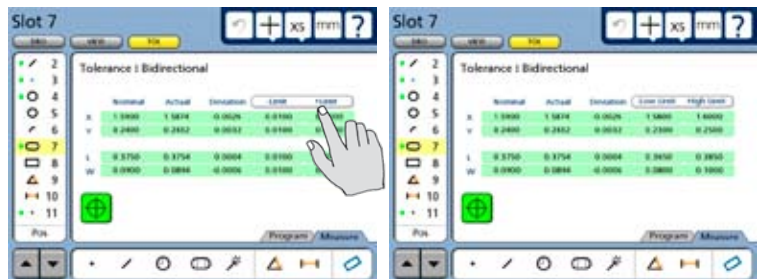

True position

True position tolerances can be applied to points, lines, circles and arcs.

Points and lines

The tolerance screens for points and lines are identical, and are used to specify the acceptable deviation from the nominal feature position. The true position tolerance compares the measured location of the center point to the nominal center point.

Enter the nominal values into the X and Y axis data fields. Enter the allowed tolerance diameter into the Tol Dia field.

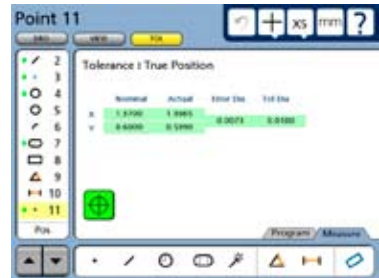

Circles and arcs

The tolerance screens for circles and arcs are identical, and are used to specify the acceptable deviation from the nominal feature position, and from the nominal diameter. The true position tolerance compares the measured location of the center point of the circle or arc to the nominal center point and compares the measured diameter to the nominal diameter. Touch the D (diameter) or r (radius) choice field in the DRO screen to toggle between the display of diameter and radius if desired.

Enter the nominal values into the X and Y axis and D (diameter) data fields provided. Enter the allowed Tol Dia (Tolerance diameter) and feature diameter limits into the Limit data fields as +/- ranges or as absolute limits. Touch the Limit data fields to toggle between +/- ranges or absolute limits.

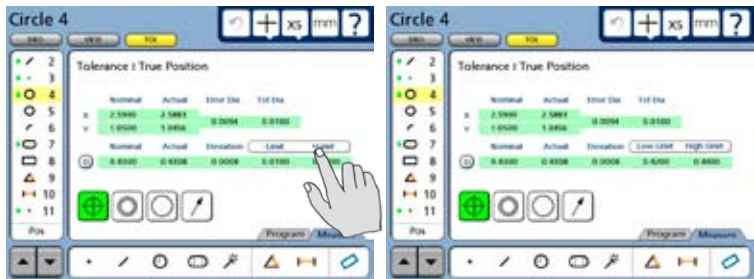

MMC/LMC (Material condition)

MMC and LMC tolerances can be applied to bosses or to bores, compare measured center locations to the nominal centers and compare measured diameters to nominal diameters. MMC and LMC tolerances can be applied to circles and arcs.

MMC Circles and arcs

The MMC tolerance screens for circles and arcs are identical, and are used to specify the maximum material that can exist within a bore or on the surface of a boss.

MMC tolerances generate position bonuses as a result of size tolerance surpluses. For example, when the size of a bore is larger than MMC, but within the acceptable tolerance range, a position tolerance bonus is generated for the bore and its acceptable location is given more flexibility. However, if a bore is within the position tolerance diameter, no position bonus is generated and the bore must be located exactly as specified.

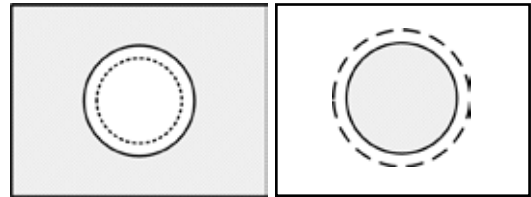

Maximum material within a bore

Maximum material on a boss

Touch the Boss or Bore choice field to specify the feature type as a Boss or a Bore.

Enter the nominal values into the X and Y axis and D (diameter) data fields provided. Enter the allowed Tol Dia (Tolerance diameter) and feature diameter limits into the Limit data fields as +/- ranges or as absolute limits.

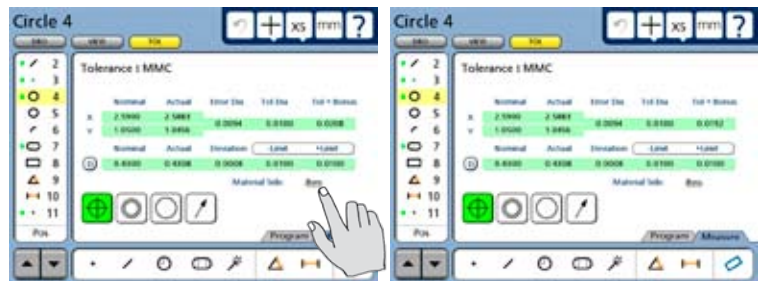

Touch the Limit data fields to toggle between +/- ranges or absolute limits.

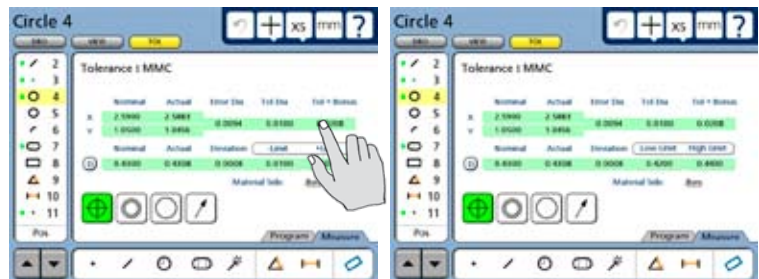

LMC Circles and arcs

The LMC tolerance screens for circles and arcs are identical, and are used to specify the minimum material that can exist within a bore or on the surface of a boss.

LMC tolerances can generate position bonuses as a result of size tolerance surpluses. For example, when the size of a bore is smaller than LMC, but within the acceptable tolerance range, a position tolerance bonus is generated for the bore and its acceptable location is given more flexibility. However, if a bore is within the position tolerance diameter, no position bonus is generated and the bore must be located exactly as specified.

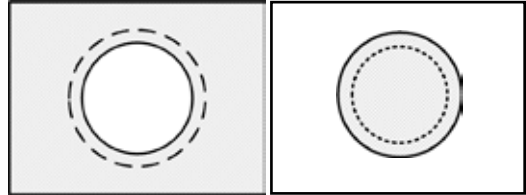

Minimum material within
a bore

Minimum material on
a boss

Touch the Boss or Bore choice field to specify the feature type as a Boss or a Bore.

Enter the nominal values into the X and Y axis and D (diameter) data fields provided. Enter the allowed Tol Dia (Tolerance diameter) and feature diameter limits into the Limit data fields as +/- ranges or as absolute limits.

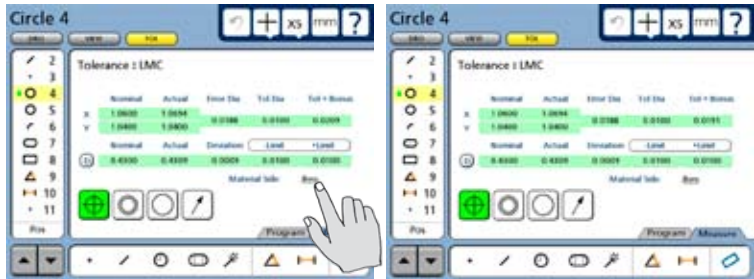

Touch the Limit data fields to toggle between +/- ranges or absolute limits.

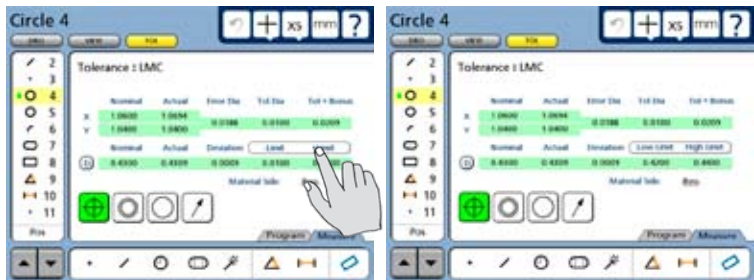

Runout

Runout tolerances can be applied to circles and arcs. The tolerance screens are identical, and are used to specify the acceptable deviation from a circle or arc around the center of the Reference feature axis.

Enter the acceptable position deviation into the Tol Zone data field and then enter the number of the reference feature for the runout tolerance into the Ref Feature data field.

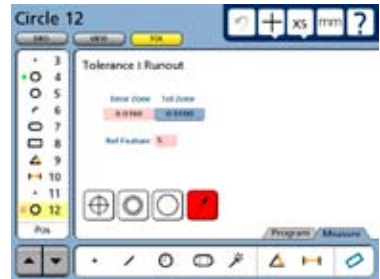

Roundness

Roundness tolerances can be applied to circles and arcs. The tolerance screens are identical, and are used to specify the acceptable deviation from a perfect circle or circle segment.

Enter the acceptable form deviation into the Tol Zone data field.

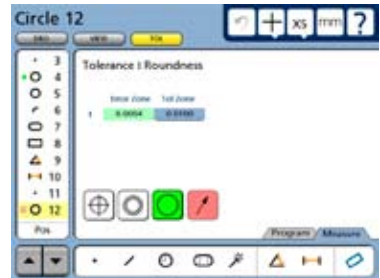

Concentricity

Concentricity tolerances can be applied to circles and arcs. The tolerance entry screens are identical, and are used to specify the acceptable position deviation from a circle or arc concentric to a Reference feature.

Enter the acceptable position deviation into the Tol Zone data field and then enter the number of the reference feature for the Concentricity tolerance into the Ref Feature data field.

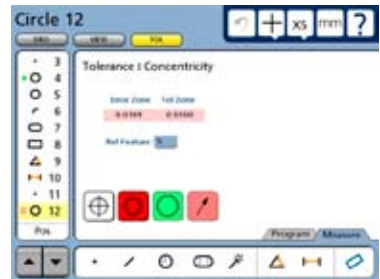

Straightness

The straightness tolerance can be applied to lines and is used to specify the acceptable deviation from a perfect line.

Enter the acceptable form deviation into the Tol Zone data field .

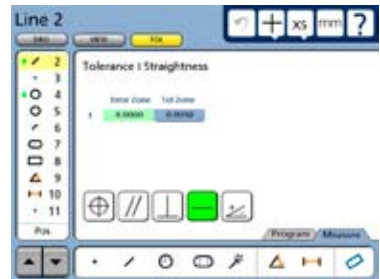

Parallelism

Parallelism tolerances can be applied to lines and are used to specify the acceptable deviation from a line perfectly parallel to a Reference feature.

Enter the acceptable parallelism deviation into the Tol Zone data field, and then enter the number of the reference feature for the Parallelism tolerance into the Ref Feature data field.

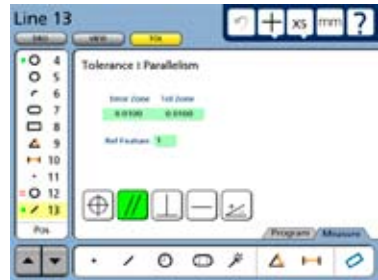

Perpendicularity

Perpendicularity tolerances can be applied to lines and are used to specify the acceptable deviation from a line perfectly perpendicular to a Reference feature.

Enter the acceptable perpendicularity deviation value into the Tol Zone data field, and then enter the number of the reference feature for the Perpendicularity tolerance into the Ref Feature data field.

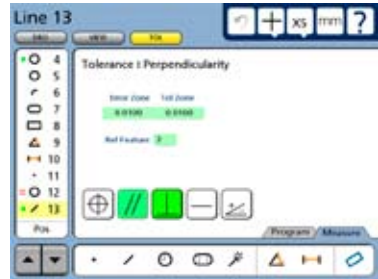

Angle

Angle tolerances can be applied to lines and angles. The tolerance screens are identical, and are used to specify the acceptable deviation from a nominal angle.

Enter the allowed angle limits into the Limit data fields as +/- ranges or as absolute limits. Touch the Limit data fields to toggle between +/- ranges or absolute limits.

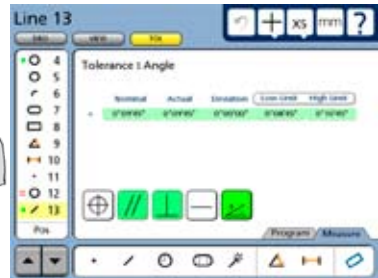
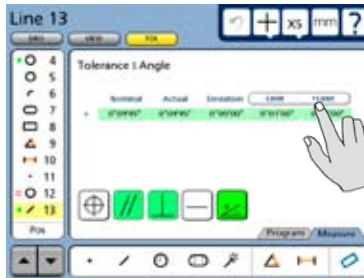

Width

Width tolerances can be applied to distances and are used to specify the acceptable deviation from a nominal length. The length can be specified as a vector length (L) or as separate X, Y and Z lengths.

Enter the allowed width limits into the Limit data fields as +/- ranges or as absolute limits. Touch the Limit data fields to toggle between +/- ranges or absolute limits.

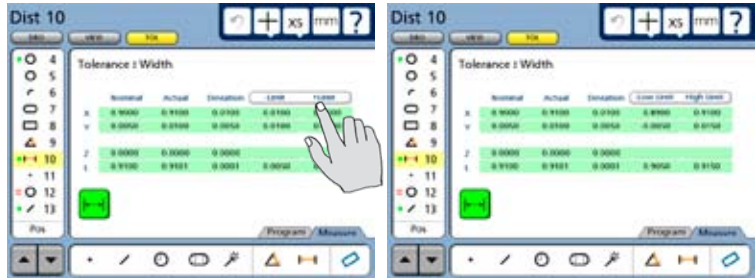

Chapter 8:

Programming

QC-300 programs are sequences of measurement activities performed on a part by the operator and stored by the system for playback later on other identical parts. Using the programming capabilities of the QC-300 greatly increases productivity by compressing the many manual steps required to measure, tolerance and report part dimensions into a few semi-automated steps which are little more than operator responses to system prompts.

Programs can be:

- Created (recorded)
- Edited
- Run on new parts
- Archived
- Deleted

Creating programs

The basic programming process shown here is identical for all part types. The details of program recording are described in the remaining pages of this section and are included in an example that measures the largest hole in the QC Quickie slide, applies a position tolerance and prints the results.

Enter messages that will be displayed for the operator as the program is played back. Messages can be inserted anywhere in the program.

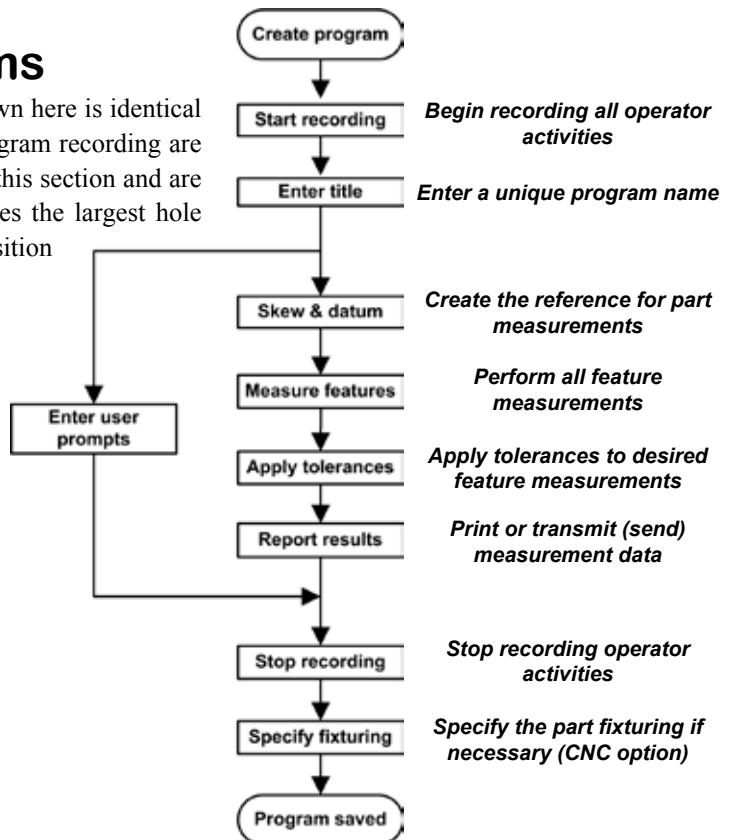

Start program recording

Touch the Program tab to display the programming tools. When no previous programs have been recorded, only the record icon will be shown. When other programs already exist, all the program tool icons will be shown.

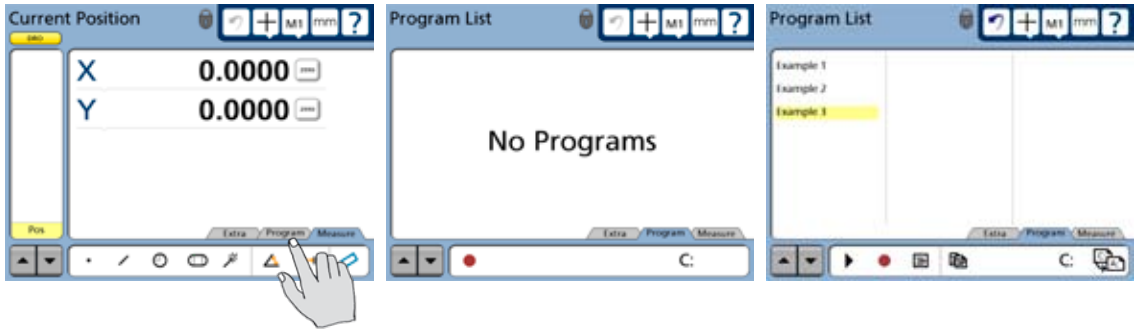

Touch the Program tab...

to display the record icon when no other programs exist, or...

to display all the programming icons when other programs do exist

Touch the record icon to begin recording a program. The program title entry screen will be displayed.

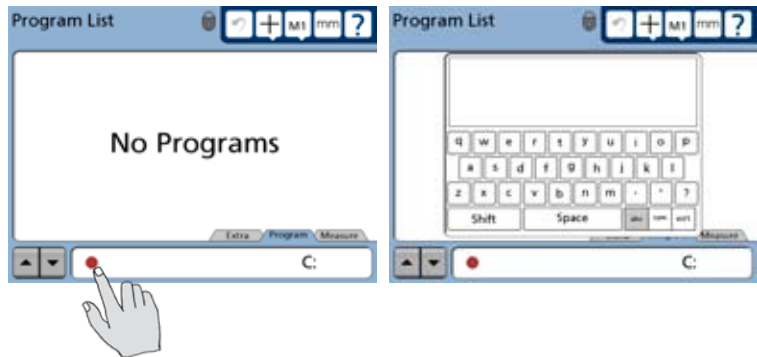

Touch the record icon...

to display the title entry screen

Enter a program title (or user message)

The method used to enter a program title is also used to enter any text message that will be played back during program execution as a user prompt.

To enter a program title:

Touch the character and control keys on the text entry screen to enter a unique name for your new program. The number keys on the front panel can also be used to enter numeric characters. Characters can be upper or lower case and can be separated by spaces.

Touch the sym or int'l control keys to enter symbol or international characters.

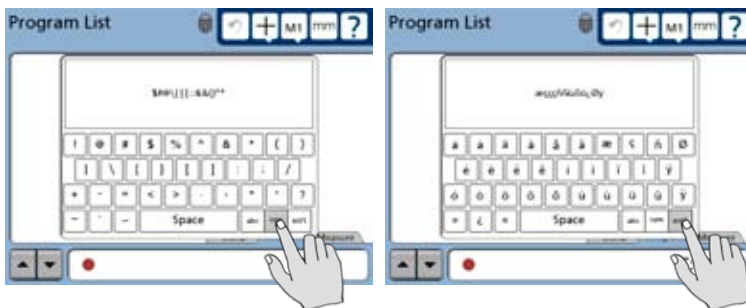
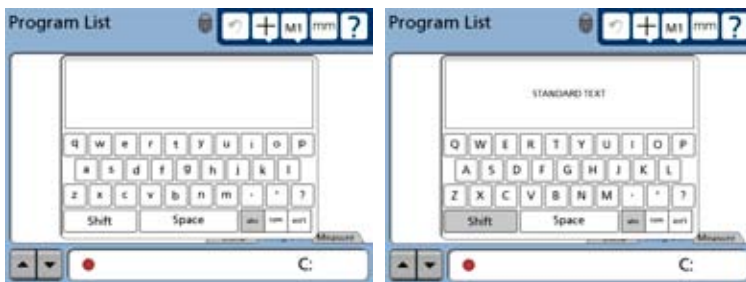

Press the Finish key to enter the new program name and begin recording the program. The DRO screen will be displayed.

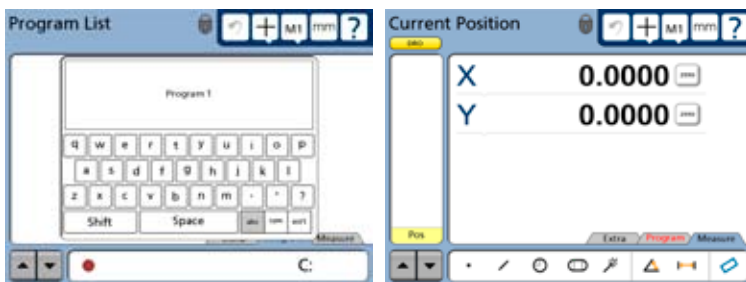

The system is now ready to record all datum, measurement, tolerance and reporting activities. Perform all the datum, measurement, tolerance and reporting activities just as you would if a program were not being recorded. Program recording is conducted by the system in the background and is invisible to the operator.

Measure a skew and create a datum

Skew and datum operations are described in [Chapter 6: Measuring](#). In this example, the bottom edge of the part is measured for skew compensation, the left edge is measured and the intersection point of the bottom and left edges is zeroed in the X, Y and Z axes and used as a datum for subsequent measurements.

Measure the skew and left side and then construct a zero datum point at the intersection of the two lines.

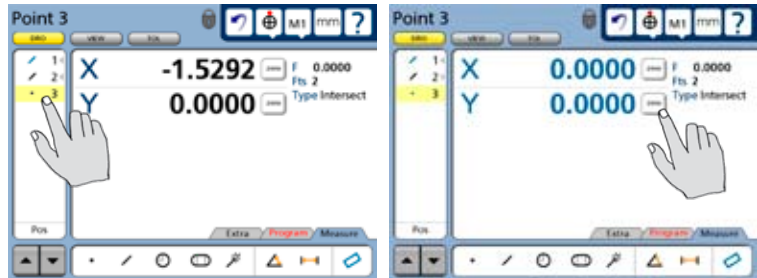

Create a zero datum for subsequent measurements

Measure a feature (include a message)

Feature measurements are described in [Chapter 6: Measuring](#). In this example, the largest hole in the QC Quickie slide is measured.

First, create a message that prompts the user to measure the hole. Press the Finish key to complete the message.

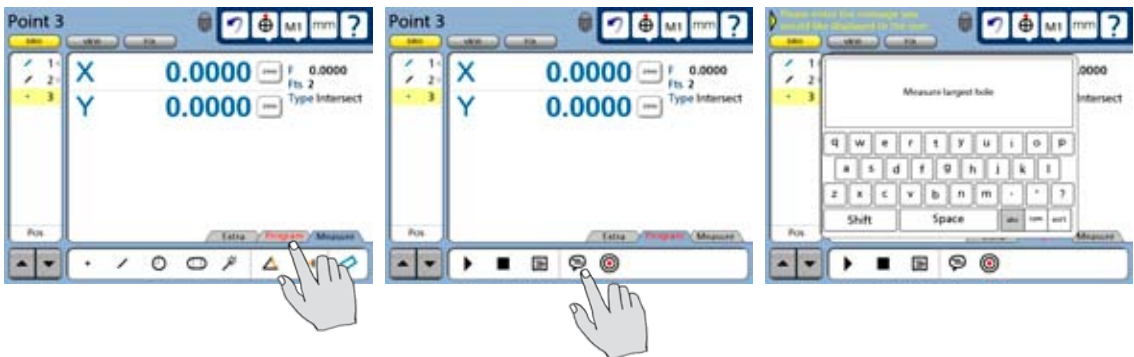

Display the Program tools...

Touch the message icon...

include a user prompt message and press Finish

Then measure the largest hole in the QC Quickie slide. Details of performing circle measurements are described in [Chapter 6: Measuring](#).

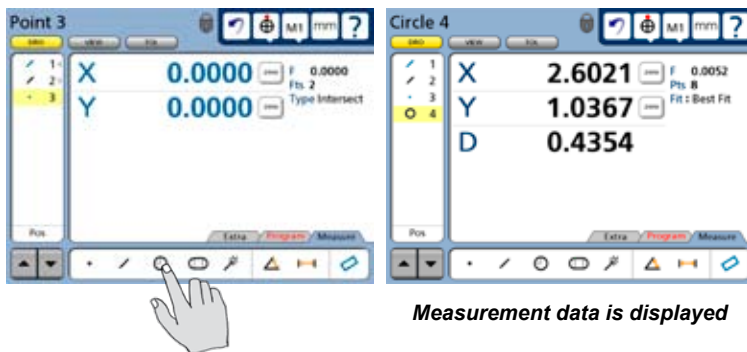

Measurement data is displayed

Apply a tolerance

Tolerance operations are described in [Chapter 7: Tolerancing](#). In this example, a true position tolerance is applied to the hole feature measured in the last step.

Touch the Tol button to display the Tolerance screen, apply the true position tolerance and touch the DRO button to return to the DRO screen.

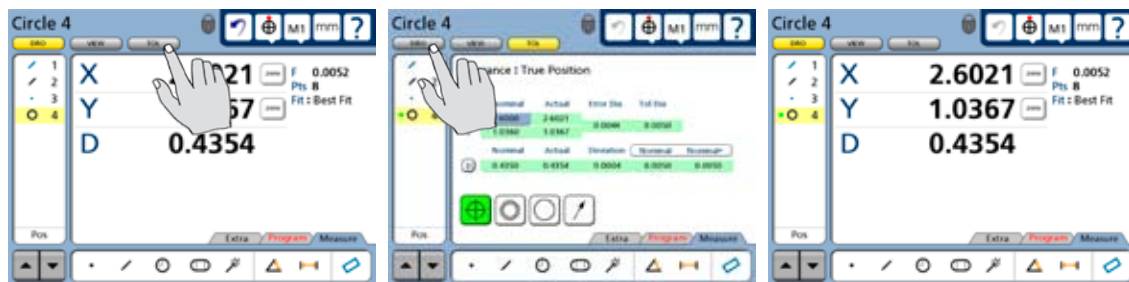

Touch the Tol button...

apply the tolerance and touch the DRO button...

to return to the DRO screen

Report results

Measurement results can be printed over the USB port or transmitted to a computer over the RS232 serial port. Parameters governing reports and data transmissions are configured in the Print setup screen described in [Chapter 9: Communication](#), and in [Chapter 10: Setup](#).

Result reporting is included in a program by simply pressing the Print key while in recording a program.



Stop the program recording

Touch the Program tab to display the programming icons, and then touch the Stop icon to stop recording the program. The program title will be shown.

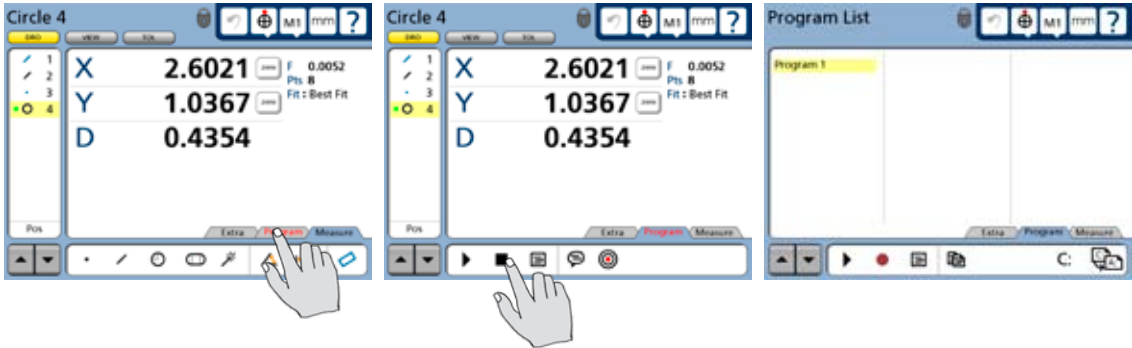

Touch the Program tab...

and then touch the Stop icon...

the new program name will be shown

The program is now saved and can be edited or run on new parts.

Touch the Measure tab to return to the measure mode of operation.

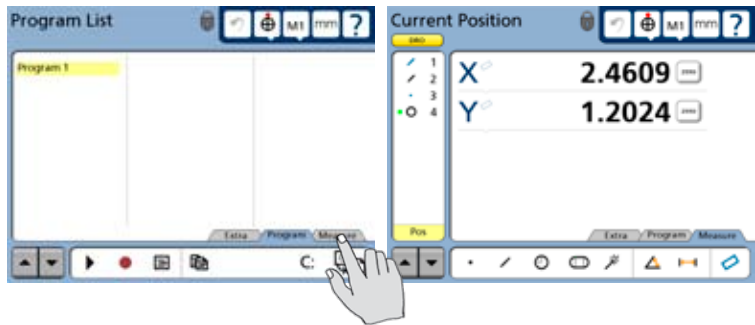

Touch the Measure tab...

to return to the DRO

Specifying part fixturing (CNC option)

Default part fixturing is configured in the CNC General setup screen by OEMs and Distributors for CNC systems. In most cases, part fixturing will remain unchanged. However, if fixturing requirements change, the part fixture configuration can also be changed to insure that subsequent program runs will include the correct measurement reference and datum.

Any of three fixturing modes can be selected in the Program Settings screen:

None

No part fixturing is used, a measurement reference and datum must be created by the user for each part prior to measurements.

Temporary

Temporary part fixturing is used, a measurement reference and datum must be created for the first part by the user, thereafter the system will perform measurement reference and datum measurements automatically for each part.

Permanent

The part fixturing is permanently attached; this is a dedicated fixture. The system retains the measurement reference and datum as part of the program, no user interaction is required to create a measurement reference or datum.

To specify the desired fixturing mode in a program:

- 1 Touch the Program tab to display programming tools.
- 2 Highlight the desired program and touch the Edit icon to display its program steps.
- 3 Touch the Fixturing Mode choice field repeatedly to cycle through the available fixturing modes.

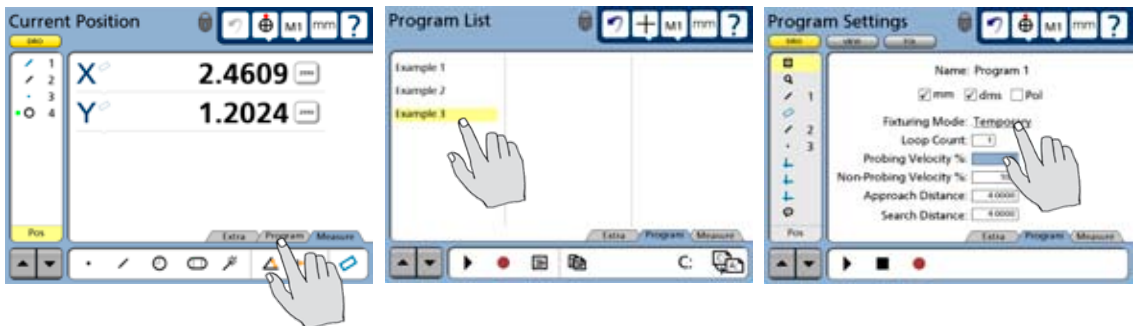

Touch the Program tab...

then select the desired program...

and cycle through fixturing modes

Editing Programs

Programs can be edited to:

- Revise units of measure
- Revise tolerances
- Revise user prompt messages
- Append new steps to the end of the list of program steps

Editing existing steps

The process for editing existing steps is diagrammed below and is identical for all types of revisions.

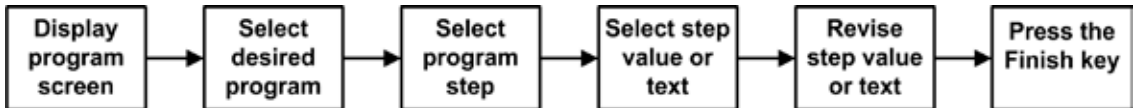

A message will be displayed at the beginning of an edit session warning the user that the current feature list will be cleared and asking for confirmation before continuing. Touch OK to clear the current feature list and begin editing the selected program.

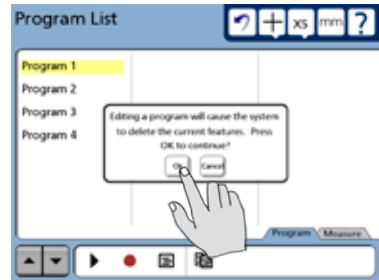

Editing program settings

Program settings are contained in the initial two program steps and include units of measure, part fixturing, program loop count, probing characteristics and magnification. With the exception of the loop counter, which determines the number of program executions, these settings are initially configured in setup screens described in Chapter 10: Setup.

To edit program settings:

- 1 Touch the Program tab, the program title and the Edit icon. Program steps will be displayed.



Touch the Program tab...

select a program and touch the Edit icon, settings will be displayed

2 Touch the first or second step to display the desired settings fields and perform the required edits.

Select the first step to edit units, fixturing, loop count or probing characteristics. Select the second step to edit magnification.

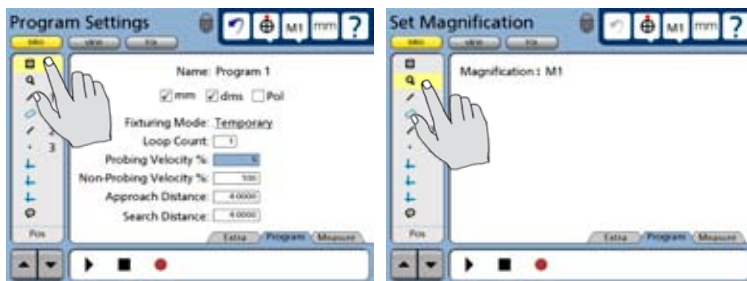

The first two steps contain program settings

3 Press the Finish key to save the changes and return to the program list.



Editing tolerances

Tolerances are contained in the feature measurement data associated with each feature in the feature list. Tolerances are initially assigned in tolerance screens when features are measured, as described in [Chapter 7: Tolerancing](#).

To edit tolerances:

- 1 Touch the Program tab, the program title and the Edit icon. Program steps will be displayed.



Touch the Program tab...

select a program and touch the Edit icon, settings will be displayed

- 2 Touch the desired feature and then touch the Tol button to display the tolerance screen.

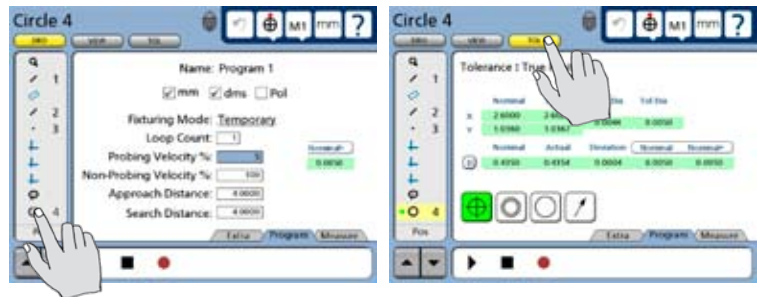

Select a feature...

and display the tolerance screen

- 3 Edit tolerances and then press the Finish key to save the changes and return to the program list.

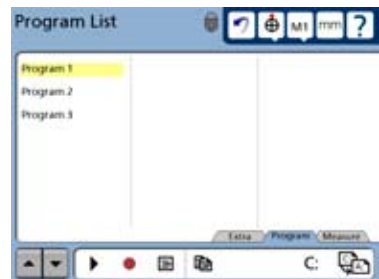

Editing user prompt messages

To revise message text:

- 1 Touch the Program tab, the program title and the Edit icon. Program steps will be displayed.



Touch the Program tab...

select a program and touch the Edit icon, settings will be displayed

- 2 Touch the desired message icon and then touch the message text to display the text entry screen.

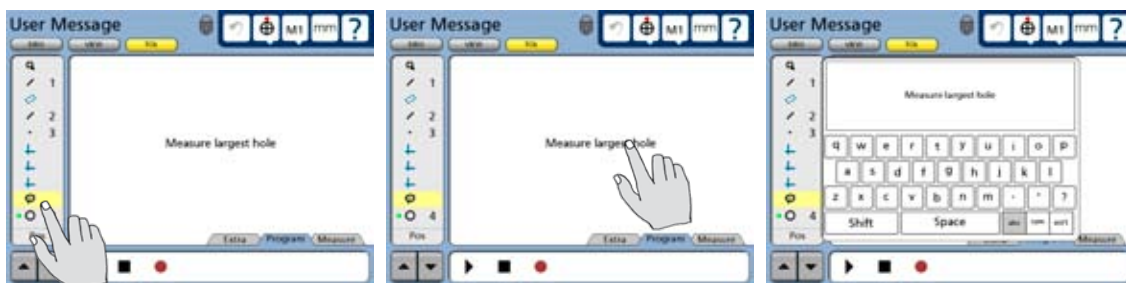

Select a message...

and touch the text...

to display the text entry screen

- 3 Edit the message and then press the Finish key to save the changes and return to the program list.

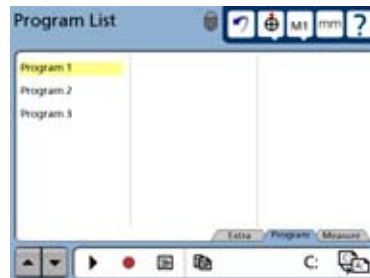

Inserting or appending new program steps

To insert new steps into an existing program:

- 1 Touch the Program tab, the program title and the Edit icon. Program steps will be displayed.



Touch the Program tab...

select a program and touch the Edit icon, settings will be displayed

- 2 To insert steps, touch the program step before the insertion point for the new program steps. To append steps, touch the last step. Then touch the Record icon. A message will ask you to confirm your intention. To continue, touch Yes. In this example steps will be inserted after the message.



Select an insertion point...

touch the record icon...

and confirm by touching Yes

- 3 The QC-300 will begin recording and the DRO will be displayed. Perform the new measurement steps. In this example a line is measured.

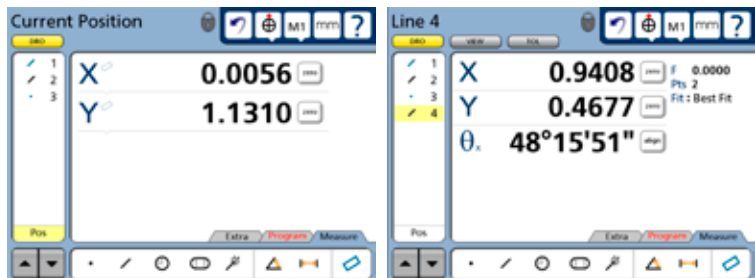

Perform the new measurement steps

4 Touch the Program tab and the Stop icon. The new program steps will be displayed at the insertion point.

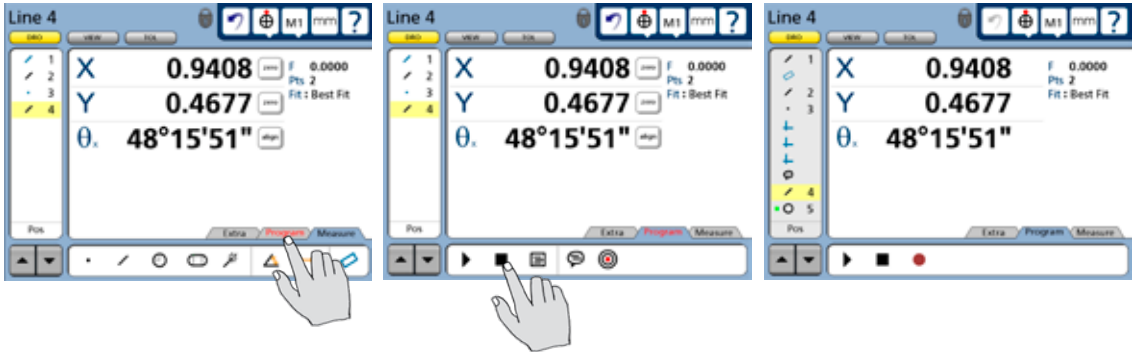

Touch the Program tab...

and then press the Stop icon to complete the addition of new steps

5 Press the Finish key to save the changes and return to the program list.



Running programs

The operator will position the part and collect measurement data points in response to program text and the green run-time arrow displayed on the screen. When the program has successfully completed executing, feature data will be shown in the feature list and the screen will leave the program execution mode and display the current position.

To run a program:

- 1 Touch the Program tab to display the program screen, touch a program title to select the desired program and then touch the Run icon to run the selected program

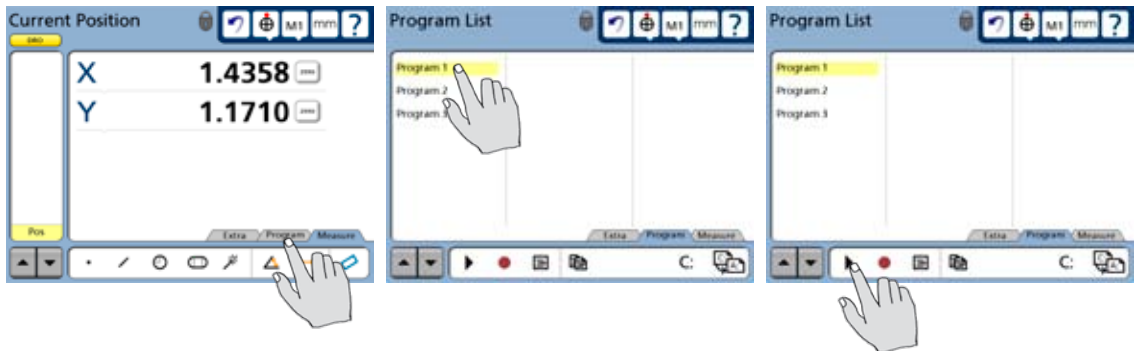

Touch the Program tab...

select the program to run..

and then touch the Run icon

During execution, after the datum is established, text and the green run-time arrow will guide the operator through the program measurement steps.

When the program is finished, the feature data will be shown in the Feature list and the current position will be shown.

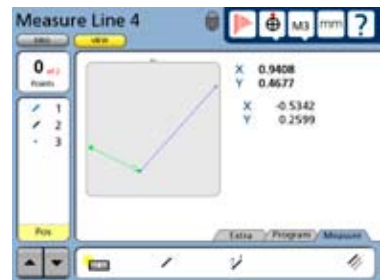

The runtime arrow guides the user

Saving and retrieving programs

Programs can be saved by themselves, or included in settings files and saved as part of the complete collection of all QC-300 system settings. In either case, the files can be retrieved later and used again. Refer to [Chapter 10: Setup](#) for details regarding saving system settings files.

Saving programs

To save programs:

- 1 Touch the Program tab to display the program screen, touch a program title to select the desired program and then touch the Copy icon to save the selected program to the USB drive (A:).

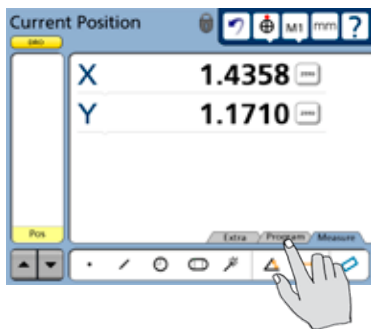

Touch the Program tab...

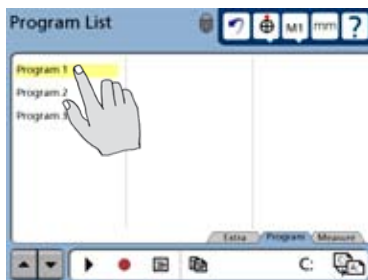

select the program to save..

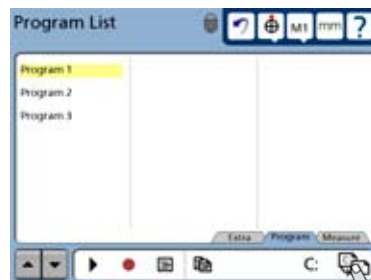

and then touch the Copy icon

Retrieving programs

To retrieve programs:

- 1 Touch the Program tab to display the program screen, touch drive letter to select the USB drive (A:) and then touch the Copy icon. The program will be added to the program list.

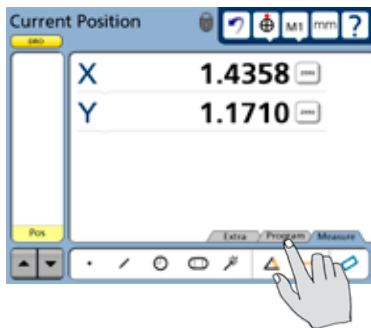

Touch the Program tab...

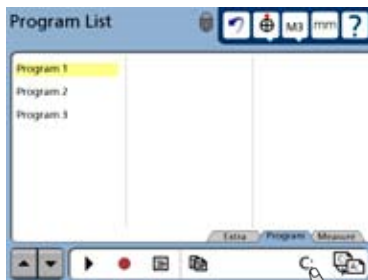

then touch the drive letter...

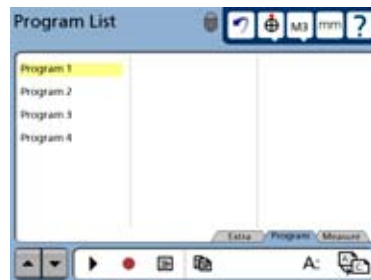

to select the USB drive

2 Select the desired program and touch the Copy icon. The selected program will be copied to the local drive (C:). Touch the drive letter again to show the contents of the local drive.

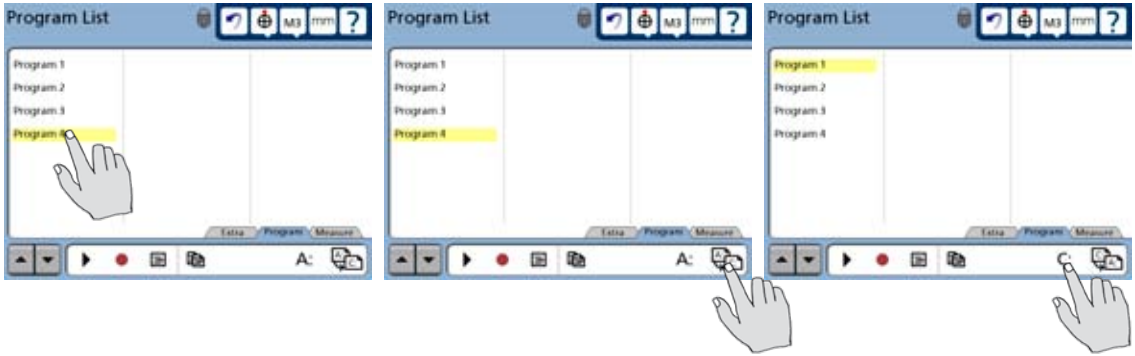

Select a program...

touch the Copy icon...

and return to the local drive

Deleting programs

Programs are deleted by selecting the desired program and pressing the Cancel key. You will be asked to confirm your intention to delete the program.

To delete a program:

1 Touch the Program tab to display the program screen, touch a program title to select the desired program and press the Cancel key to delete the program. Then touch the Yes button to confirm your intention.

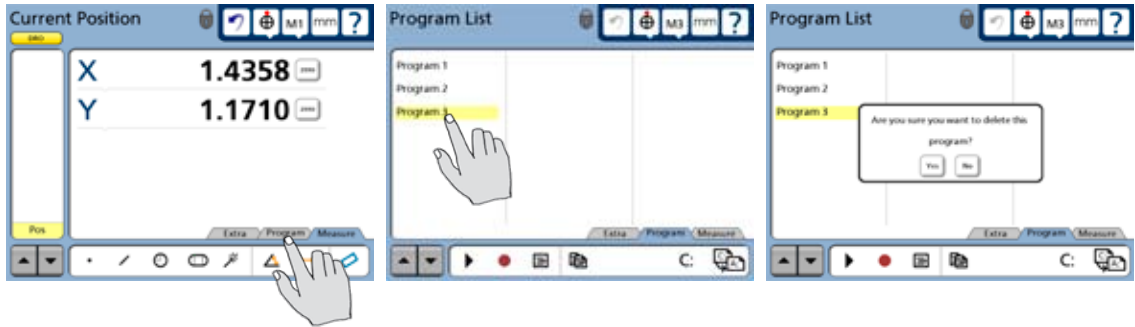

Touch the Program tab...

select a program and press Cancel..

and confirm your intention

Chapter 9:

Communication

The QC-300 can communicate with a computer over the RS232 serial port and with printers over the USB port.

Connecting to a computer

- 1 Verify that the QC-300 and computer power are off.
- 2 Connect a computer COM port to the QC-300 RS-232 serial port using a standard straight-through serial cable (Metronics part number 11B12176). Make sure the cable connectors are tight, but do not overtighten the connector screws.
- 3 Apply power to the computer, and then the QC-300. The default QC-300 settings for communication over the RS-232 serial port are shown here.

- Baud rate: 1200
- Parity: None
- Data bits: 7
- Stop bits: 1
- EOC Delay: 0
- EOL Delay: 0

- 4 Launch the computer application that will be used to communicate with the QC-300, and configure the communication properties of the COM port to match those of the QC-300.



Sending data to a computer

Measurement data can be sent to a computer over the RS-232 serial port in the following formats:

- None No data will be sent to the computer
- Select User will be prompted to select the data that will be sent
- Report A standard report of all feature data or a tolerance report of only features that have tolerances applied will be sent

To send data to a computer:

1 Touch the question mark Icon and display the setup menu, then touch Print to display the Print setup screen.

2 Verify that the desired data is specified in the Print Button choice field. None, Select or Report can be specified. In this example, the Report is specified.

3 Verify that the Serial Device is specified in the Destination field. In this example, the communication will be with a computer, so the Serial port is specified.

4 Verify that the desired report is specified in the Report Type setup choice field. Standard, Export or Tolerance can be specified. In this example, a Tolerance report is specified.

5 Specify other settings that are consistent with the computer application's requirements.

6 Press the Finish key to exit the setup mode, and then press the Print key to send the data to a computer.

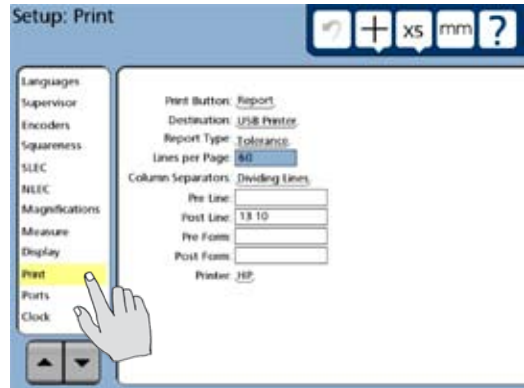

Connecting a printer

The QC-300 supports certain USB printers. The printer must be approved for use by Metronics. The current printer is shown in the Print setup screen discussed in [Chapter 10: Setup](#).

- 1 Verify that the QC-300 and printer power are off. Connect the USB printer to the USB Type A port on the side of the enclosure.
- 2 Make sure the USB cable plug is fully inserted.



Printer format strings

The formatting strings listed below include one or more ASCII codes listed at the end of this chapter. This formatting is configured in the Print setup screen discussed in [Chapter 10: Setup](#).

- Pre Line: ASCII control character (or string) for printer control before printing a line.
- Post Line: ASCII control character (or string) for printer control after printing a line.
- Pre Form: ASCII control character (or string) for printer control before printing a form.
- Post Form: ASCII control character (or string) for printer control after printing a form.

Report formats

Reports of feature measurement data can be printed with the formats discussed in the Print setup screen portion of [Chapter 10: Setup](#). These can include:

- Number of lines per page
- Form
- Pre/Post line formats
- Pre/Post formats
- Axis labels
- Units of measure

QC-300 Feature Print Out						
Date _____	Time _____		Operator _____			
Job _____			Part _____			
NO.	FEATURE	ID	UNITS	POSITION	DIMENSION	FORM
001	Point	1	mm A DMS	X = -0.876 Y = -0.175		
002	Line	2	mm A DMS	X = -0.120 Y = -0.152	< = 82.41.16	+T = 0.000 -T = 0.000
003	Circle	3	mm A DMS	X = 0.464 Y = -0.073	r = 0.073 d = 0.145	+T = 0.000 -T = 0.000
004	Distance	4	mm A DMS		X = 2.273 Y = 0.711	
005	Line	5	mm A DMS	X = 0.116 Y = 0.174	< = 30.15.23	+T = 0.000 -T = 0.000
006	Line	6	mm A DMS	X = -0.116 Y = -0.174	< = 77.44.45	+T = 0.000 -T = 0.000
007	Angle	7	mm A DMS	X = -0.063 Y = 0.070	<1= 132.30.37 <2= 227.29.22	
008	Line	8	mm A DMS	X = 0.000 Y = 0.000	< = 270.00.00	+T = -T =

Printing a report

Feature measurement data or records of QC-300 system settings can be printed at the USB port.

Printing feature measurement data

Feature measurement data can be printed in the following formats:

- None No data will be printed
- Select User will be prompted to select the data that will be printed
- Report A standard report of all feature data or a tolerance report of only features that have tolerances applied will be printed

To print feature measurement data:

1 Touch the question mark Icon and display the setup menu, then display the Print setup screen.

2 Verify that the desired data is specified in the Print Button choice field. None, Select or Report can be specified. In this example, the **Print Button: Report** is specified.

3 Verify that the Serial Device is specified in the Destination field. In this example, the file will be printed to a USB printer, so the **Destination: USB Printer** is specified.

4 Verify that the desired report is specified in the Report Type setup choice field. Standard or Tolerance can be specified. In this example, **Report Type: Standard** is specified.

5 Specify other settings that are consistent with the computer application's requirements.

6 Press the Finish key to exit the setup mode, and then press the Print key to send the data to the printer.



Printing QC-300 system settings

To print a report of the QC-300 setup parameters:

- 1 Touch the question mark icon and display the setup menu.
- 2 Press the Print key.

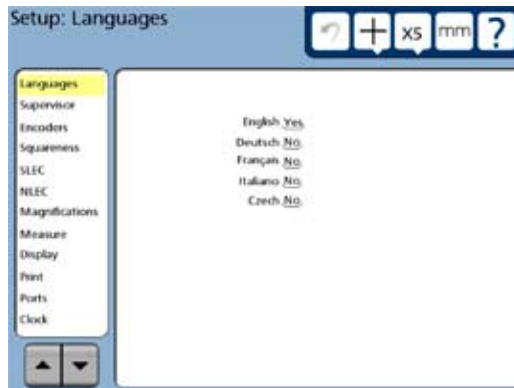

RS232 connector pin designations

Pin No.	Description	Direction
2	Data in	Input
3	Data out	Output
7	Signal ground	Reference
8	Power on	Output (always high)

ASCII Code table

ASCII Codes

8	backspace	46	.	84	T
9	horizontal tab	47	/	85	U
10	line feed	48	0	86	V
11	vertical tab	49	1	87	W
12	form feed	50	2	88	X
13	carriage return	51	3	89	Y
14	so	52	4	90	Z
15	si	53	5	91	[
16	dle	54	6	92	\
17	dcl	55	7	93]
18	dc2	56	8	94	^
19	dc3	57	9	95	~
20	dc4	58	:	96	␣
21	nak	59	;	97	a
22	syn	60	<	98	b
23	etb	61	=	99	c
24	can	62	>	100	d
25	em	63	?	101	e
26	sub	64	@	102	f
27	esc	65	A	103	g
28	fs	66	B	104	h
29	gs	67	C	105	i
30	rs	68	D	106	j
31	us	69	E	107	k
32	space	70	F	108	l
33	!	71	G	109	m
34	"	72	H	110	n
35	#	73	I	111	o
36	\$	74	J	112	p
37	%	75	K	113	q
38	&	76	L	114	r
39	'	77	M	115	s
40	(78	N	116	t
41)	79	O	117	u
42	*	80	P	118	v
43	+	81	Q	119	w
44	comma (,)	82	R	120	x
45	-	83	S	121	y
				122	z

Chapter 10:

Setup

The operating parameters of the QC-300 must be configured prior to using the system for the first time, and any time part measurement, reporting or communication requirements change. Day to day use of the QC-300 does not require reconfiguration of the system settings.

The Setup Menu	164
Accessing and using the Setup Menu	164
Essential setup requirements	168
Setup screen descriptions	169
Language screen	169
Supervisor screen	170
Encoders screen	172
Squareness screen	175
SLEC screen.....	176
NLEC screen.....	181
Magnifications screen	186
Measure screen.....	191
Display screen.....	195
Print screen.....	202
Ports screen	204
Clock screen.....	205
Sound screen.....	206
Miscellaneous screen	207
Buttons screen.....	210
Joystick screen	212
Digital positioner screen	214
Probe path screen	215
Edge values screen.....	217
Hardware screen.....	218



CAUTION

Parameter changes made in any of the setup screens affect the operation of the QC-300. For this reason setup screens should be password-protected. Only qualified supervisory personnel should be given password access to setup screens.

The Setup Menu

All setup operating parameters of the QC-300 are configured using screens accessed from the setup menu. Touching setup menu items on the left side of the setup screen display the corresponding setup parameter data fields and choice fields on the right side of the screen.

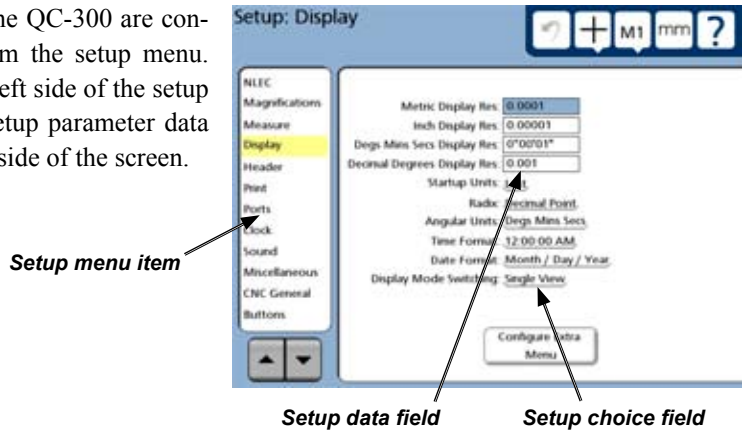

Parameters configured in setup screens will be retained by the QC-300 until:

- The data-backup battery is changed
- The system data and settings are cleared by maintenance personnel
- They are changed using the setup menu screens
- Certain software upgrades are performed

Accessing and using the Setup Menu

QC-300 operating parameters are entered into the system using touch screen selections and keys located on the front panel. The configuration process is facilitated by a simple menu structure of setup functions that can be quickly navigated on the large color LCD display.

The setup screens and functions are accessed from other screens by touching the Help (?) button, and then pressing the Setup button twice. Access to most setup parameter fields is restricted to users that can provide the supervisor password.

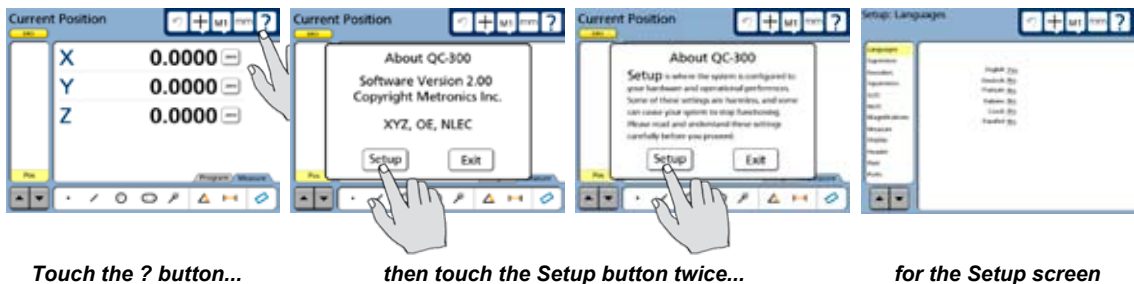

Touch the ? button...

then touch the Setup button twice...

for the Setup screen

Entering the supervisor password

The supervisor password must be entered into the Supervisor setup screen to access most setup fields. To enter the supervisor password:

1 Access the setup menu as described on the previous page.

2 Touch the Supervisor menu item, enter the supervisor password using the number keys on the front panel and press the Enter key.



3 Setup editing privileges can be retained until the QC-300 power is cycled, eliminating the need to reenter the password if another setup editing session is required. Touch the Keep Privileges choice field to toggle the Keep Privileges parameter from No to Yes.

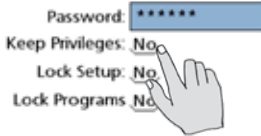

4 Views of the Setup can be locked so that the supervisor password is required to see the setup parameter settings. Touch the Lock Setup choice field to toggle the Lock Setup parameter from No to Yes, then delete the password from the Password field and press the Finish key.

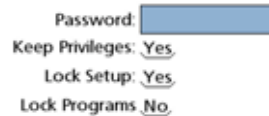
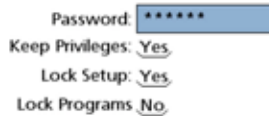

5 Operator access to program functions can be limited to running existing programs by toggling the Lock Programs choice field to Yes. Touch the Lock Programs choice field to toggle the setup parameter from No to Yes.



Selecting items from the Setup Menu

Setup menu items are selected by touching the item on the left side of the screen. Menu items will become highlighted to indicate that the selection is complete and the corresponding setup parameter choice and data fields will be shown on the right side of the screen. Touch the up or down scroll arrow to scroll to the desired menu item.

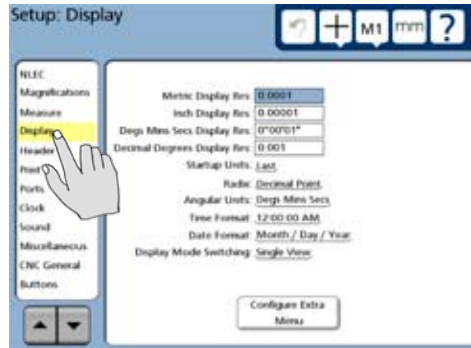

Selecting setup parameter choices

Many setup parameters are selected from two choices: Yes or No. Other setup parameters offer more choices to the user. In all cases, selections are made by repeatedly touching the choice field to cycle through all the available parameter setting choices.

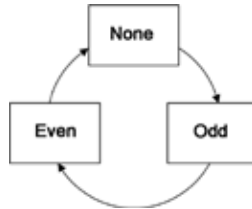

In this example, the RS232 Port Parity choices are shown by repeatedly touching the Parity choice field.

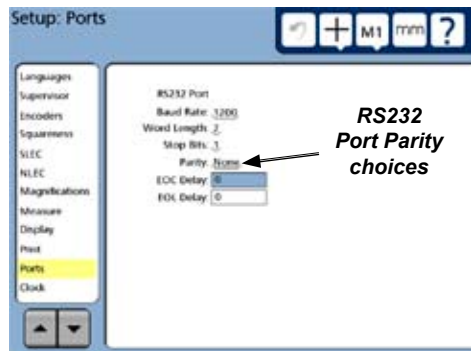

Entering and deleting setup data

Some setup parameters must be entered as numeric values into setup data fields. To enter setup data, touch the desired data field and enter the data using the number keys. In this example, the RS232 Port EOC Delay data field is selected and data is entered using the number keys. Obsolete or erroneous setup data is deleted from a highlighted data field by pressing the Cancel key.

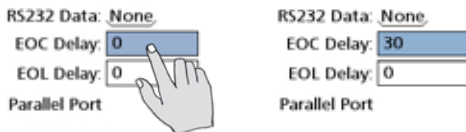
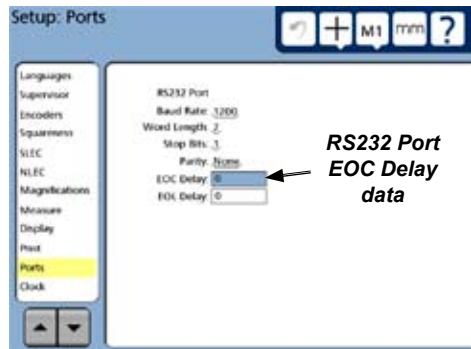

Storing a parameter and advancing to the next step

Press the Enter key to store the highlighted value and advance to the next setup field.

Leaving the setup menu

Press the Finish key to conclude the setup session.

Minimum setup requirements

In most cases, the QC-300 will be provided by a Metronics distributor or an OEM and will be configured and ready to use. Setup by the end-user will be unnecessary. However, if some setup is required, a minimum sequence of steps should be performed in the order shown by the block diagram. Each block describes a setup task and refers to pages where detailed instructions are presented.

A variety of optional setup steps can be performed after the minimum setup to specify display, reporting and other parameters. These optional and all other setup parameters and screens are described in detail in the remainder of this chapter.



Familiarize yourself with the methods of accessing and using the Setup menu described on earlier pages before performing these minimum or additional optional setup steps.

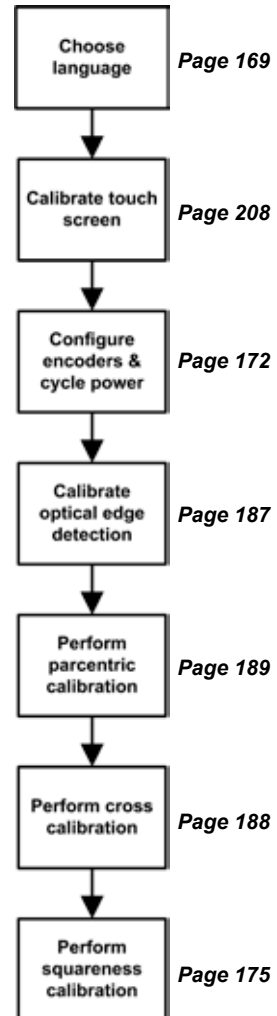

Setup screen descriptions

The setup screen descriptions are presented in the order of their appearance in the setup menu. However, the first time the QC-300 is configured, the order of setup screen use should follow the essential setup requirements diagram, and then continue in the order that best satisfies the application or the user's preferences. The subsequent use of setup screens will probably be infrequent and will address part requirement or hardware changes.

Language screen

The Language screen contains selections for changing the language of text displayed on the LCD, included in transmitted data and printed on reports.

Specifying the displayed language

Touch the desired language to toggle the language choice to Yes.

English <u>Yes</u>	English <u>No</u>
Deutsch <u>No</u>	Deutsch <u>No</u>
Français <u>No</u>	Français <u>No</u>
Italiano <u>No</u>	Italiano <u>Yes</u>
Czech <u>No</u>	Czech <u>No</u>

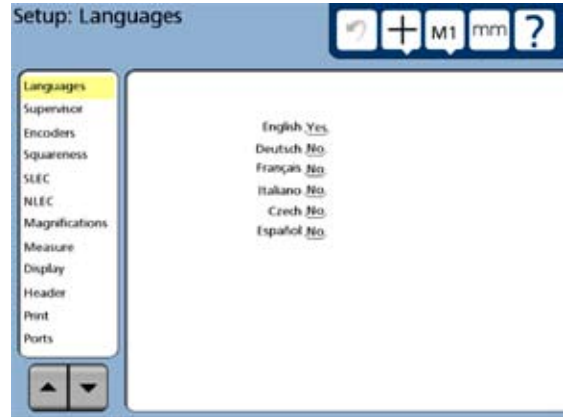

Supervisor screen

The Supervisor screen contains fields for entering the supervisor password, choosing to keep privileges until the power is cycled and locking the setup menu so that setup parameters cannot be viewed. Button controls are also provided for saving system settings to, or loading setting from the USB port.

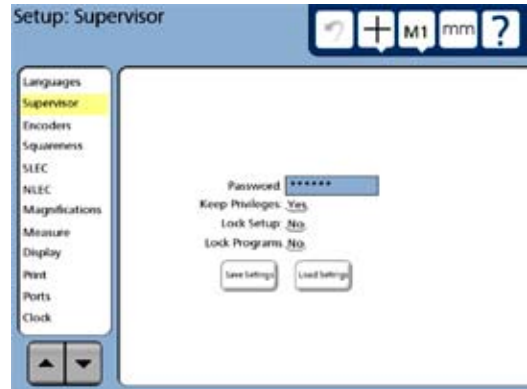

Entering the supervisor password

The supervisor password must be entered into the Supervisor setup screen to access most setup fields. To enter the supervisor password, touch the Supervisor menu item, enter the supervisor password using the number keys on the front panel and press the Enter key.

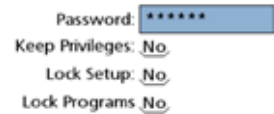

Keeping setup privileges until the power is cycled

Setup editing privileges can be retained until the QC-300 power is cycled, eliminating the need to reenter the password if another setup editing session is required. To retain setup privileges, touch the Keep Privileges to toggle the Keep Privileges parameter from No to Yes.

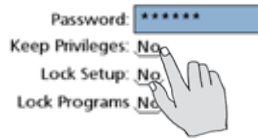

Hiding setup parameters from unauthorized personnel

Views of the Setup can be locked so that the supervisor password is required to see the setup parameter settings. Touch the Lock Setup choice field to toggle the Lock Setup parameter from No to Yes, then delete the password from the Password field and press the Finish key.

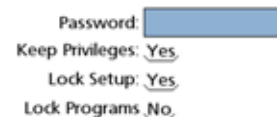
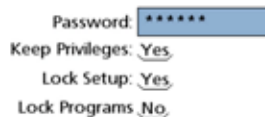

Limiting access to program functions

Operator access to program functions can be limited to running existing programs by toggling the Lock Programs choice field to Yes. Touch the Lock Programs choice field to toggle the setup parameter from No to Yes.

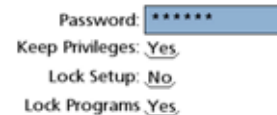

Saving and loading settings

System settings can be saved to storage devices, or loaded from storage devices attached to the USB port by connecting the USB storage device and touching the Save Settings or Load Settings button.

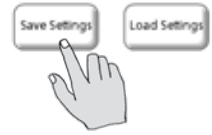

Encoders screen

The Encoders screen contains data and choice fields for specifying encoder resolution, units of measure, encoder type, reference marks and other critical encoder parameters for each measurement axis.

Selecting an axis to configure

Selections are made by repeatedly touching the Axis choice field to cycle through all the available measurement axes.

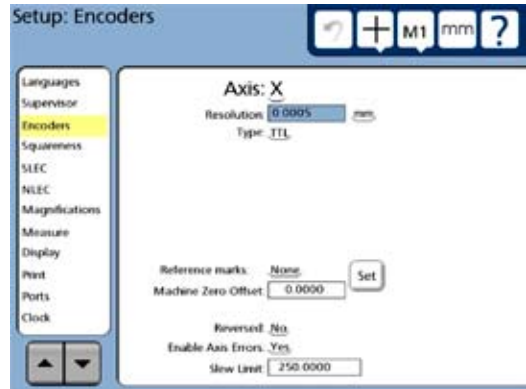

In this example, the measurement axis choices (X, Y and Z) are cycled by repeatedly touching the Axis choice field.



Specifying encoder resolution

Encoder resolution is entered into the Resolution data field using the numeric keys on the front panel.

Specifying encoder type

Encoder type is toggled between TTL and Analog by touching the Type choice field.

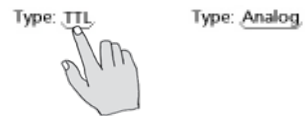

Selecting reference marks

Selections are made by repeatedly touching the Reference marks choice field to cycle through all the available encoder reference mark types.

In this example, the reference mark choices (None, Manual, Single and Absolute) are cycled by repeatedly touching the Axis choice field.

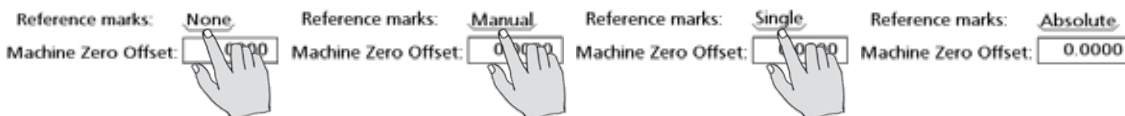

None

No encoder reference marks are used. Machine zero will be established at the encoder locations encountered when the system is powered on. The machine zero location can be changed at any time using the Machine Zero Set function described later in this chapter.

Manual

You will be prompted to move the stage to position the encoders at a point that you wish to use as machine zero each time the system is powered. The manual reference mark selection is commonly used with “hard stop” machine references. The machine zero location can be changed at any time using the Machine Zero Set function described later in this chapter.

Single

You will be prompted to move the stage to cross encoder reference marks on each axis each time the system is powered. The reference mark crossing points of each encoder are used to determine the machine zero position. The machine zero location can be changed at any time using the Machine Zero Set function described later in this chapter.

Absolute

Selecting Absolute reference marks causes a Teach button to be displayed. Touch the Teach button to initiate a process that will guide you through the steps required to cross encoder reference marks. Follow the instructions provided on the screen. You will be prompted to move the stage to cross reference marks on each axis. The reference mark crossing points of each encoder are used to determine the machine zero position. Sometimes the resulting machine zero position for absolute reference marks can be located outside the stage boundaries. In these cases, this machine zero location can be changed by the user to a more convenient “home” position for measurements using the Machine Zero Set function described on the next page.

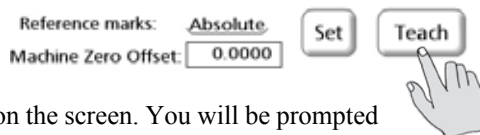

Setting a new machine zero reference

A machine zero is established each time the QC-300 is powered. However, it might be necessary or convenient to change the location of the machine zero position to a new “home” position for measurements. To set a new machine zero position:

Select the Machine Zero Offset data field, move the stage to the desired new machine zero position and touch the Set button. The new machine zero for the current axis will be established and the offset displacement from the original machine zero to the new machine zero will be shown in the Machine Zero Offset data field. Repeat this process for each axis.

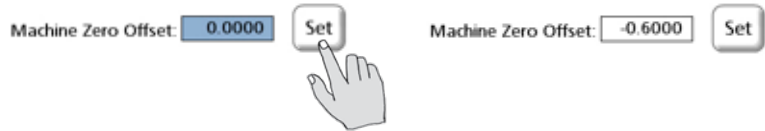

CAUTION

SLEC and NLEC encoder error correction values are referred to a repeatable machine zero location. If the machine zero location is set to a different XY position, SLEC and NLEC correction values will no longer be valid.

Reversing the encoder count direction

Encoder count direction for each axis is toggled between normal and reversed by repeatedly touching the Reversed choice field.

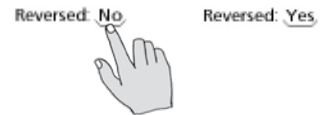

Enabling axis error messages

Encoder error messages for each axis can be displayed on the LCD. These messages are enabled or disabled by repeatedly touching the Enable Axis Errors choice field.



Specifying slew limit

The encoder data rate limit of the system is 500,000 counts per second. An encoder error message is displayed when the encoder rate of travel exceeds the encoder velocity shown in the Slew Limit data field. The Slew Limit velocity is calculated using the formula:

$$\text{Slew Limit} = (500,000 \text{ counts/second}) \times (\text{encoder resolution distance/count})$$

For example, a 0.0005 mm/count encoder would have a Slew Limit of 25 mm/sec

$$\text{Slew Limit} = (500,000 \text{ counts/second}) \times (0.0005 \text{ mm/count}) = 25 \text{ mm/sec}$$

To change the velocity limit value, touch the Slew Limit data field and enter a new velocity.



Squareness screen

The Squareness screen contains data and choice fields for calibrating the squareness of the measuring system. The calibration of stage squareness requires the use of a certified square artifact. To calibrate squareness:

- 1 Place the square calibration artifact on the stage with one edge along the X-axis.
- 2 Measure the angle of the square calibration artifact (ideally 90 degrees).
- 3 Select the Observed Angle data field, enter the measured angle using the number keys and press the Enter key to highlight the Standard Angle field.
- 4 Enter the actual angle of the square calibration artifact obtained from the artifact's certification document into the Standard Angle data field.
- 5 Touch the Enabled choice field to toggle the field to ON.

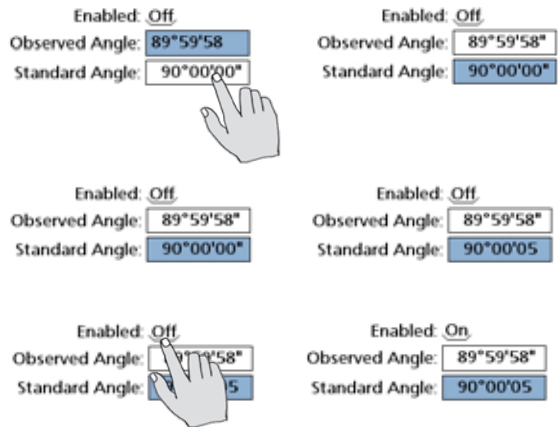
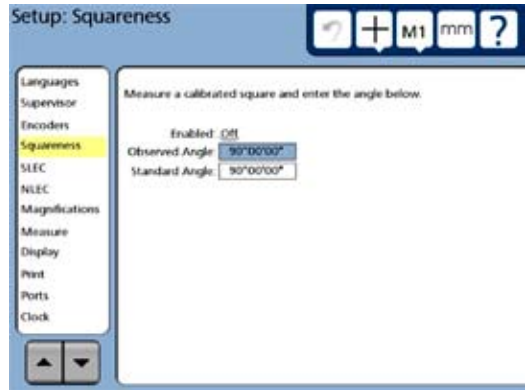

SLEC screen

The SLEC screen contains fields for enabling and configuring linear error correction (LEC) or segmented linear error correction (SLEC) for each encoder axis.

LEC or SLEC, which is right for my application?

Any channel input device can include slight nonlinearities over its measurement range. LEC compensates for nonlinearities by applying a single linear correction value to the entire range of measurement. SLEC compensates for nonlinearities by applying correction values to the individual nonlinear segments of the measurement range.

LEC is the easiest error correction to set up, but does not provide correction for individual nonlinearities that could be present over small portions of the entire range. SLEC error correction can result in more accurate measurements, but requires more time and effort to set up.

If an overall nonlinearity exists without significant individual errors across the scale, LEC can be applied as an overall correction method. However, if an encoder is thought to have significant individual nonlinearities across the range of measurement, SLEC should be applied as the correction method.

LEC (Linear error correction)

LEC compensates for encoder nonlinearities by applying a single linear correction value to the entire range of measurement. The procedure for configuring the LEC error correction is diagrammed and explained below.

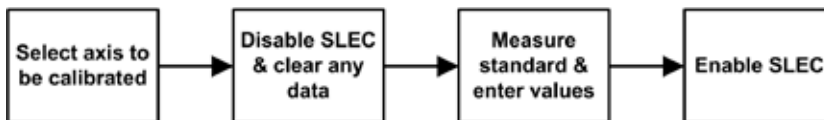

1 Touch the SLEC menu item and then touch the Axis choice field repeatedly to cycle to the desired axis.

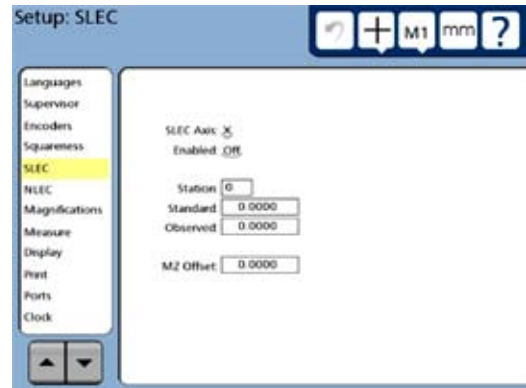

2 Make sure the Enabled choice field is toggled to Off, and erase any existing data in all the data fields using the methods described earlier in this chapter. Station 0 should be displayed with zeros in the Standard, Observed and MZ Offset fields when this step is complete.

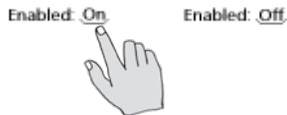

SLEC Axis: X
 Enabled: Off

Station: 0
 Standard: 0.0000
 Observed: 0.0000
 MZ Offset: 0.0000

3 The length of the calibration standard should cover as much of the axis range of motion as possible. Measure the standard and enter the Standard (certified) and Observed (measured) values into the corresponding data fields.

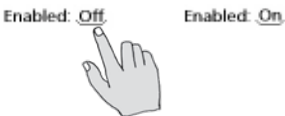

SLEC Axis: X
 Enabled: Off

Station: 0
 Standard: 200.001
 Observed: 199.867
 MZ Offset: 0.0000

4 Touch the Enabled choice field to toggle error correction On.

SLEC (Segmented linear error correction)

SLEC compensates for encoder non-linearities by applying correction values to individual nonlinear segments. These SLEC correction values are created by the QC-300 system using data provided by the user in the SLEC Setup screen. The SLEC setup data provided by the user consists of Standard (certified) and Observed (measured) values of a standard, or standards that cover the entire range of axis motion.

The SLEC measurements can divide the axis range of motion into up to 150 segments. The example diagrammed on the next page shows standard values compared to observed values for 6 segments. The deviation (difference between standard and observed) is also shown. Segments are defined as any straight line on the graph of deviations, beginning with segment zero.

The standard and observed values at the end of each segment are entered as data for a station in the SLEC Setup screen. For example, the standard and observed values at the end of segment 0 on the diagram are 40 and 40, and are entered into the Standard and Observed data fields for station 1.

When the procedure is complete and setup data are entered, correction values will be calculated for the encoder based on the standard and observed values at the end of the segments. The procedure for configuring the SLEC error correction is diagrammed and explained below.

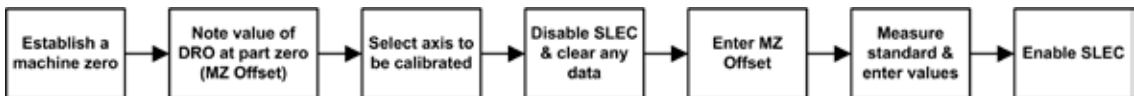

1 Cycle the power to establish a repeatable machine zero. You will be prompted to move the encoders to cross reference marks or perform a hard stop to the establish machine zero. Perform the machine zero operation.



NOTE

If a hard stop zero is performed, the same stop will be required each time the QC-300 is started.

2 The length of the calibration standard should cover as much of the range of axis motion as possible. Move the stage to position the encoder of the axis being calibrated at the beginning (part zero position) of the calibration standard. Make a note of this calibration axis value shown in the DRO; this will be entered later as the machine zero (MZ) Offset.

3 Access the setup menu, touch the SLEC menu item and then touch the Axis choice field repeatedly to cycle to the axis that will be calibrated.

SLEC Axis: X



SLEC Axis: Y



SLEC Axis: Z



SLEC Axis: X

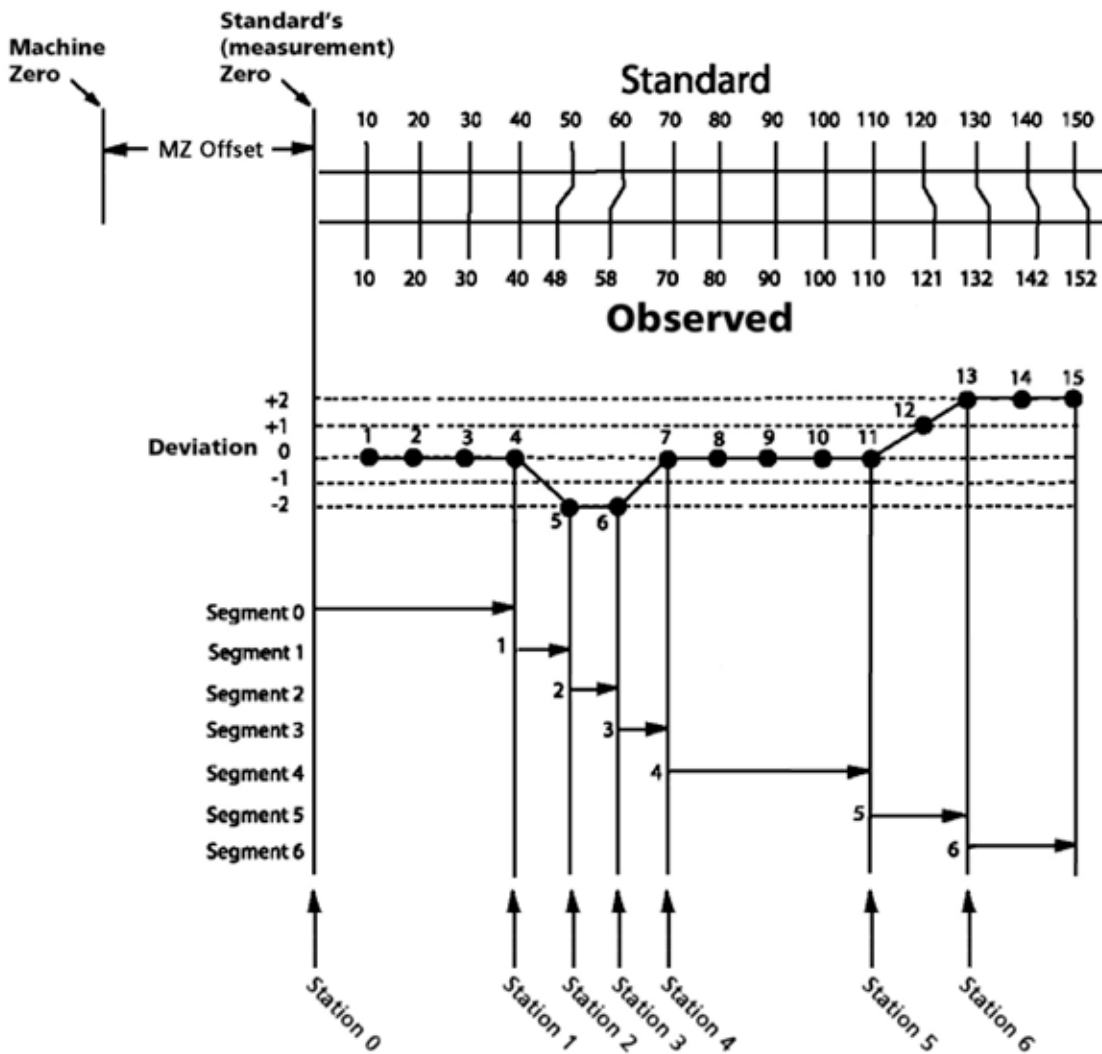

4 Make sure the Enabled choice field is toggled to Off, and erase any existing data in all the data fields using the methods described earlier in this chapter. Station 0 should be displayed with zeros in the Standard, Observed and MZ Offset fields when this step is complete.

Enabled: On Enabled: Off



SLEC Axis: X
Enabled: Off

Station:	0
Standard:	0.0000
Observed:	0.0000
MZ Offset:	0.0000

5 Enter the MZ Offset value noted earlier in step 2.

SLEC Axis: X
Enabled: Off

6 Zero the DRO for the axis being calibrated at the part zero position of the standard and enter zeros into the Standard and Observed data fields for Station zero.

Station:
Standard:
Observed:

MZ Offset:

7 Measure the standard, incrementing the Station number and entering the Standard (certified) and Observed (measured) values into the corresponding data fields for each segment.

This example shows measurements across 150 mm on the X-axis, and the SLEC screens for entering the six segments of standard and observed data to provide error correction.

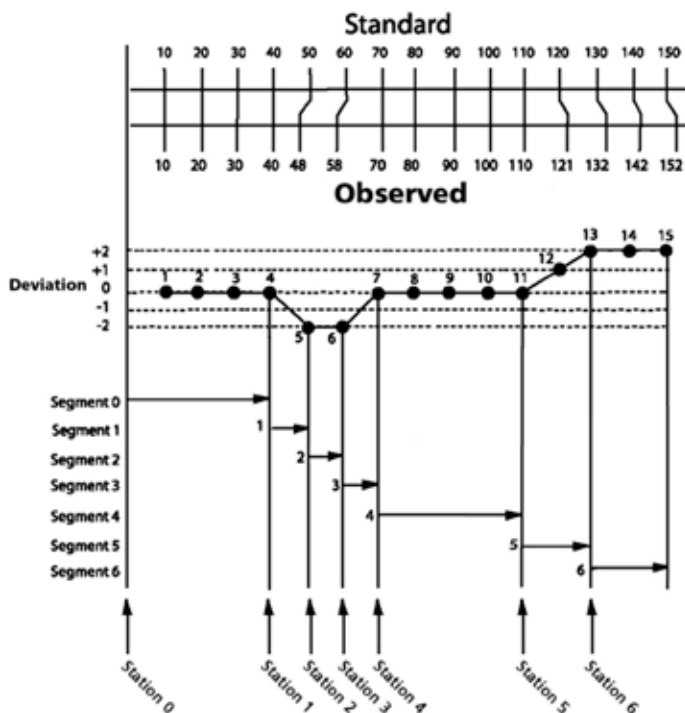

Reminder

Segments are straight lines on the deviation graph. Only the beginning and end points of each straight line segments must be entered into SLEC data fields.

SLEC Axis: <input checked="" type="checkbox"/> X Enabled: <input type="checkbox"/> Off	SLEC Axis: <input checked="" type="checkbox"/> X Enabled: <input type="checkbox"/> Off	SLEC Axis: <input checked="" type="checkbox"/> X Enabled: <input type="checkbox"/> Off	SLEC Axis: <input checked="" type="checkbox"/> X Enabled: <input type="checkbox"/> Off	SLEC Axis: <input checked="" type="checkbox"/> X Enabled: <input type="checkbox"/> Off	SLEC Axis: <input checked="" type="checkbox"/> X Enabled: <input type="checkbox"/> Off
Station: <input type="text" value="1"/> Standard: <input type="text" value="40.000"/> Observed: <input type="text" value="40.000"/>	Station: <input type="text" value="2"/> Standard: <input type="text" value="50.000"/> Observed: <input type="text" value="48.000"/>	Station: <input type="text" value="3"/> Standard: <input type="text" value="60.000"/> Observed: <input type="text" value="58.000"/>	Station: <input type="text" value="4"/> Standard: <input type="text" value="70.000"/> Observed: <input type="text" value="70.000"/>	Station: <input type="text" value="5"/> Standard: <input type="text" value="110.000"/> Observed: <input type="text" value="110.000"/>	Station: <input type="text" value="6"/> Standard: <input type="text" value="130.000"/> Observed: <input type="text" value="132.000"/>
MZ Offset: <input type="text" value="0.2475"/>	MZ Offset: <input type="text" value="0.2475"/>	MZ Offset: <input type="text" value="0.2475"/>	MZ Offset: <input type="text" value="0.2475"/>	MZ Offset: <input type="text" value="0.2475"/>	MZ Offset: <input type="text" value="0.2475"/>
Station 1 of 6	Station 2 of 6	Station 3 of 6	Station 4 of 6	Station 5 of 6	Station 6 of 6

8 Touch the Enabled choice field to toggle it On.

SLEC Axis: X
Enabled: On

Station:
Standard:
Observed:

MZ Offset:

NLEC Screen

The NLEC screen contains fields for enabling and configuring nonlinear error correction (NLEC) for the X and Y encoder axes.

Nonlinear error correction minimizes or eliminates the small inaccuracies in the X-Y measurement plane due to encoder linearity, mounting and machine-travel imperfections. Error correction coefficients are obtained by measuring a certified calibration grid. When the grid is measured, values are compared to either the ideal grid values as described by the Grid Size and Cell Size fields, or to the certified grid values listed in an artifact calibration file (.acf file).

This comparison of measured values to ideal or actual values results in the final NLEC.txt file that contains the error corrections for all measured grid locations. When NLEC is enabled, the corrections will be applied across the entire range of X-Y measurement to minimize or eliminate the inaccuracies mentioned earlier.

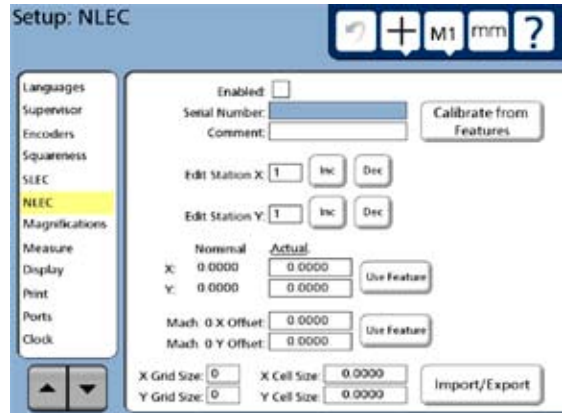

.acf Files

When no .acf file is used, the calibration grid values are assumed to be ideal. When grid certification values are available, an .acf file can be created easily using a word processor application. The format of the .acf file is shown here with an example 3 X 3 grid and corresponding example .acf file. Create a text file of actual grid values from the certification sheet and save the file using the nlec.acf file name and extension.

.acf file format

Unit of measure	Skew axis
Size of Y cells	Size of X cells
Number of X points	Number of Y points
First X grid value	First Y grid value
Next X grid value	First Y grid value
Next X grid value	First Y grid value
.	.
.	.
.	.
Next X grid value	Last Y grid value
Last X grid value	Last Y grid value

Example 3 X 3 grid

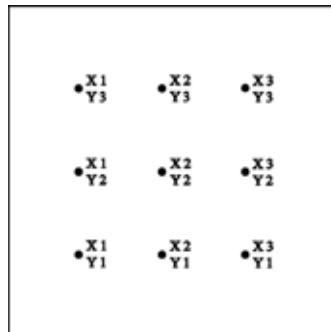

Example .acf file

mm	X
25.4	25.4
3	3
0.0000	0.0000
25.4003	0.0001
50.7998	0.0003
-0.0002	24.3997
25.4001	25.4004
50.8003	24.3999
0.0001	50.8001
25.4004	50.8004

Nonlinear error correction calibration can be performed using one of three methods:

- Calibrate from features obtained by measuring the calibration grid using the QC-300.
- Edit existing QC-300 calibration values if calibration adjustments are required.
- Import calibration values (NLEC text file) collected earlier by measuring the calibration grid using a QC-5000.

The first two methods listed above can use artifact calibration files (.acf files) to specify certified artifact calibration grid values.

Calibrating from features

The process of calibrating from features is shown by this chart and described below. In most cases this method is performed in the field.

1 Make sure that NLEC is disabled (Enabled checkbox is cleared). Enabled:

2 Define the grid. The grid size and cell size data entry fields are shown at the bottom of the NLEC setup screen.

X Grid Size: X Cell Size:
Y Grid Size: Y Cell Size:

Enter the grid size in terms of the number of X and Y grid points, and then enter the cell size in terms of the distance between points.

3 Load an .acf file of certified values if desired.

Insert a USB drive into the USB port containing the nlec.acf file at the root of the drive, and the

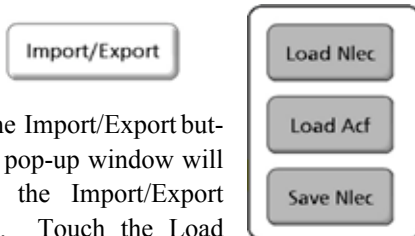

touch the Import/Export button. A pop-up window will display the Import/Export choices. Touch the Load Acf button.

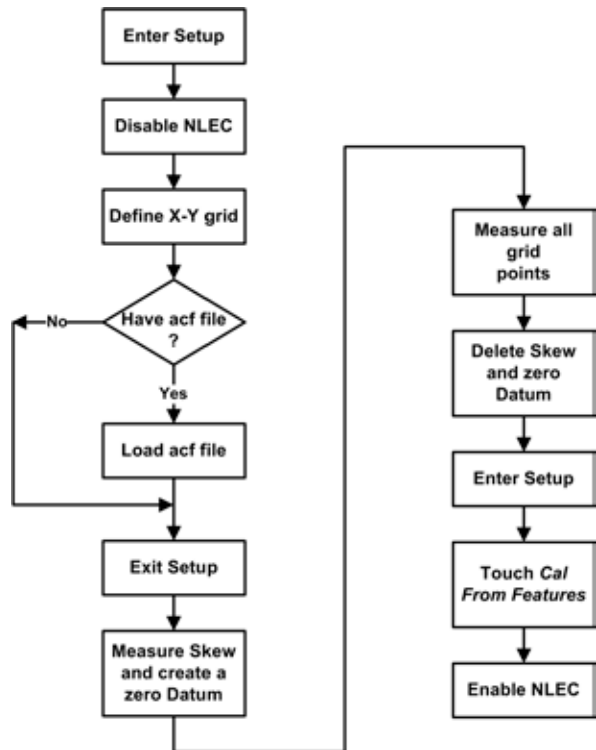

4 Exit the setup mode, measure the skew through the bottom grid points of the calibration grid and create a zero datum at the lower left point of the grid.

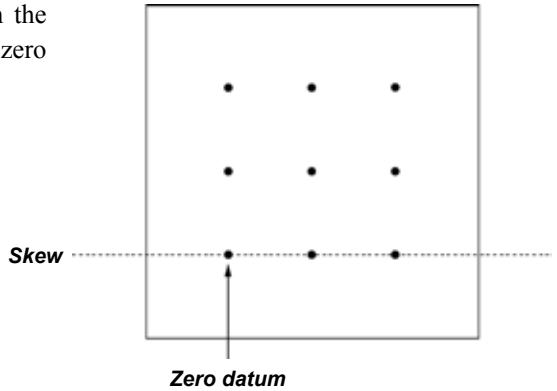

5 Measure the grid values starting at the bottom left corner of the grid (X1, Y1) and proceed from left to right and from bottom to top. Be sure that the X and Y values at the lower left corner of the grid are zero.

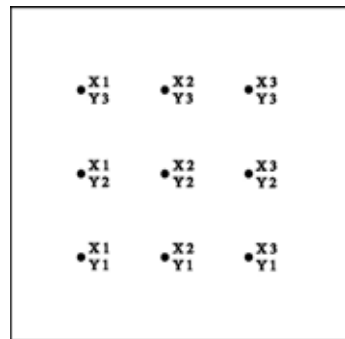

6 Delete the skew and zero datum features from the feature list.

7 Return to the NLEC setup screen.

8 Touch the Calibrate from Features button. A message will show the resulting machine zero offset change. If the change seems reasonable, touch OK.

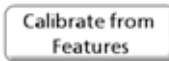

9 Enable NLEC error correction Enabled:

Calibrating NLEC by adjusting station values

The process of calibrating by adjusting station values is shown by this chart and described below. This process is generally used to adjust existing NLEC calibration data.

1 Make sure that NLEC is disabled (Enabled checkbox is cleared). Enabled:

2 Define the grid. The grid size and cell size data entry fields are shown at the bottom of the NLEC setup screen. Enter the grid size in terms of the number of X and Y grid points, and then enter the cell size in terms of the distance between points.

X Grid Size: X Cell Size:
Y Grid Size: Y Cell Size:

3 Load an .acf file of certified values if desired. Insert a USB drive into the USB port containing the nlec.acf file at the root of the drive, and then touch the Import/Export button.

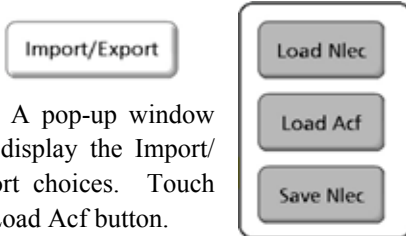

A pop-up window will display the Import/Export choices. Touch the Load Acf button.

4 Exit the setup mode, measure the skew through the bottom grid points of the calibration grid and create a zero datum at the lower left point of the grid.

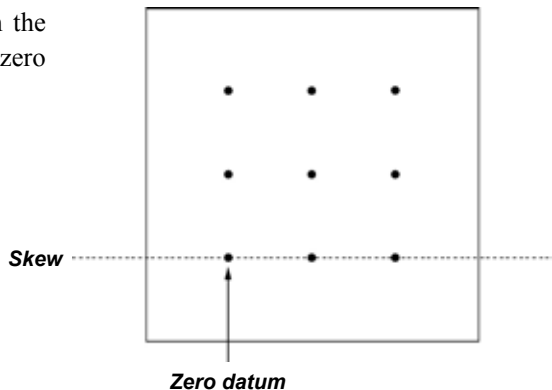
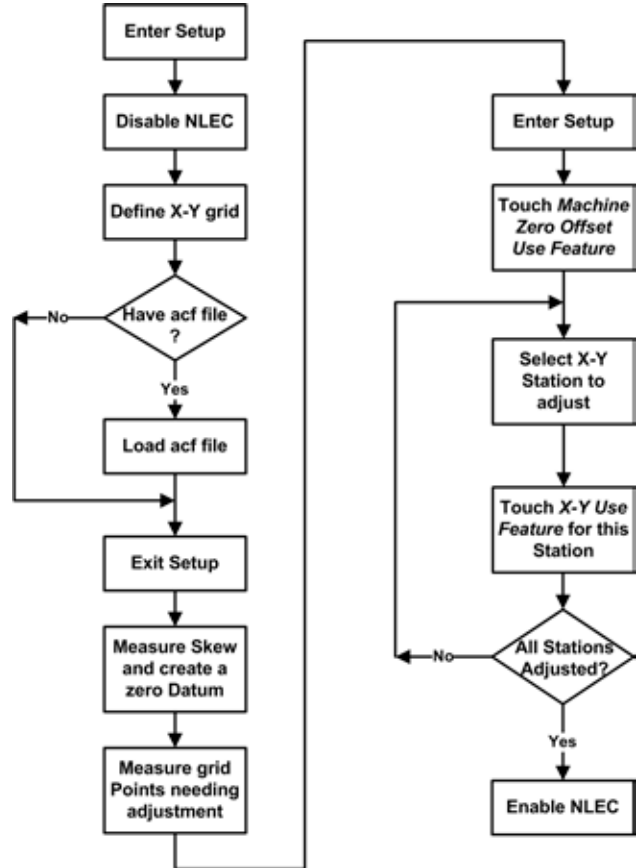

5 Measure only the grid values that need to be adjusted, starting at the bottom left corner of the grid (X1, Y1) and proceeding from left to right and from bottom to top.

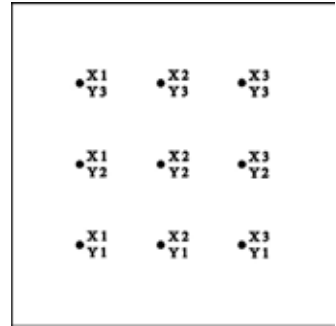

6 Return to the NLEC setup screen.

7 Touch the (Machine 0 Offset) Use Feature button to set the zero datum.

Mach. 0 X Offset:

Mach. 0 Y Offset:

8 Select the grid station to be adjusted by incrementing or decrementing the Edit Station X and Edit Station Y values, then touch the (X/Y) Use Feature button to replace the existing value with a recently measured value.

Edit Station X:

Edit Station Y:

	Nominal	Actual	
X:	0.0000	<input type="text" value="0.0000"/>	<input type="button" value="Use Feature"/>
Y:	0.0000	<input type="text" value="0.0000"/>	

9 Continue this process until all the desired calibration values have been adjusted.

10 Enable NLEC error correction. Enabled:

Calibrating NLEC by importing an existing NLEC correction text file

The process of calibrating by importing an existing NLEC file is shown by this chart and described below. This process is generally used by distributors and OEMs that have created NLEC.txt Files for the stage using a QC-5000.

1 Plug a USB drive into the USB port of the QC-300 that contains an nlec.txt file at the root of the USB drive.

2 Open the NLEC setup screen and make sure that the NLEC feature is disabled (Enabled checkbox is empty). Enabled:

3 Touch the Import/Export button to import the NLEC file from the USB drive.

4 Check the Enabled checkbox if necessary. Enabled:

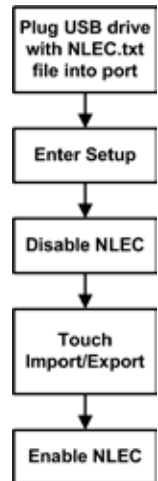

Magnifications screen

The magnifications screen contains fields and tools for adding and deleting magnifications, installing and calibrating optical edge detection, cross-calibrating crosshair and edge detector probes and performing par-centric calibrations.

Adding magnifications

To add a magnification, touch the New button. The next higher ID number and default button label will be added.

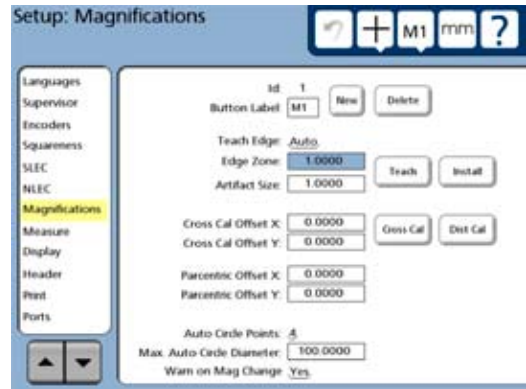
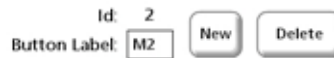
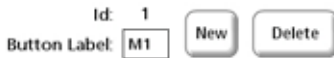

The button label can be changed to any three digit alphanumeric character string by touching the Button Label data field and deleting or entering characters using the keyboard screen or the front panel keys.

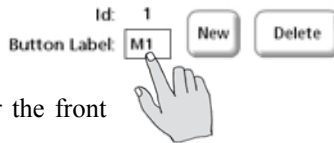

Use the Cancel key to delete characters. Use the Finish key to complete and store the new label.



Deleting magnifications

To delete a magnification, touch the Magnification button, select the magnification to be deleted, and then touch the Delete button.

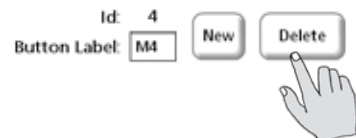
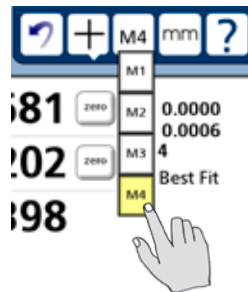

Edge calibrations for routine measurements

Teaching the edge detector calibrates it to correctly recognize dark to light transitions (edges) on the comparator screen. Perform a teach calibration after each startup or whenever the part or magnification level changes. Any change in the light conditions on the comparator should be followed by a teach calibration. To perform the teach calibration:

1 Touch the Teach Edge button to toggle between the Auto and Double teach modes:

- Auto: The system will determine if one or two passes are required to calibrate the edge detector
- Double: Passing over a less distinct edge twice is recommended to calibrate the edge detector



2 Touch the Teach button. You will be prompted to place the edge detector probe over dark and light areas of the comparator screen and to press the Enter key. Follow the instructions provided in the upper left corner of the screen to complete the calibration.

Teach Edge: Single



3 When the teach calibration is complete, use the edge detector probe to measure a few edges to verify that the teach calibration was successful.

Edge calibrations for difficult measurements

The distance calibration is performed to teach the edge detector probe to accurately measure thick or round parts, or parts that are difficult to measure due to indistinct or fuzzy edges. It is not necessary to perform a distance calibration when measuring parts with distinct, well defined edges.



NOTE

The standard used for distance calibration should either be a “gold standard” part identical to the part that will be measured, or a standard with physical characteristics that are very similar to the part that will be measured.

To perform the distance calibration:

1 Enter the dimension that will be used for the distance calibration into the Artifact Size data field.

Artifact Size:

will be entered into the Cross Cal Offset value fields automatically by the system during the calibration process.

2 When the cross calibration is complete, use the crosshairs, and then the edge detector probe to measure the same circle and compare the measurement results to verify that the teach calibration was successful.

Performing parcentric calibrations

Parcentric calibration eliminates X and Y axis measurement offset errors that can occur when changing magnifications. Parcentric calibrations are performed using a single circle artifact in the calibration process diagrammed at the right and described below. To perform parcentric calibrations:

1 Zero any existing Parcentric and Parfocal X and Y offsets by selecting each magnification and entering zero values into the Offset X and Offset Y data fields.

Parcentric Offset X:	0.0000
Parcentric Offset Y:	0.0000

2 Select the highest optical magnification.

3 Focus the circle artifact image.

4 Measure the circle artifact and create a zero datum point at the center of the circle feature in the DRO screen. This will zero the X and Y axes at the center of the circle. Subsequent measurements of this circle artifact at other magnifications will result in X and Y axis offsets with respect to this magnification. These offsets will be entered into the Magnification setup screen for each corresponding magnification.

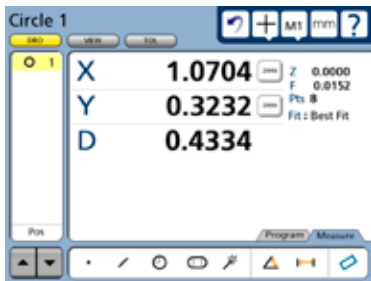

Measure a circle using the highest magnification...

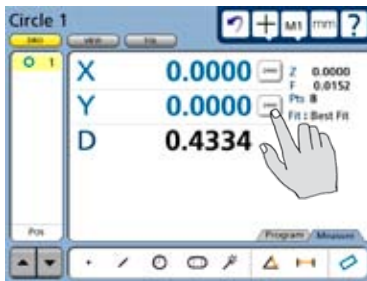

and then zero the X and Y axes to create a zero datum

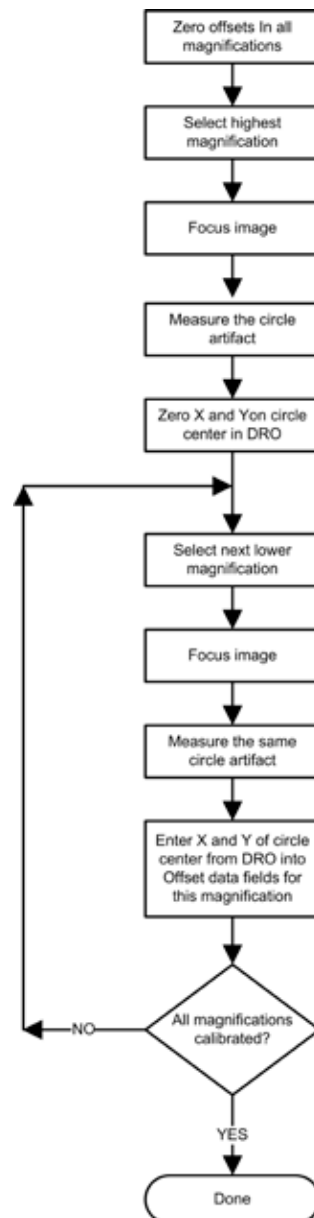

5 Select the next lower magnification. This is M2 in this example.

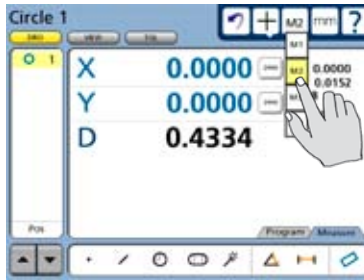

6 Focus the circle artifact image at the new magnification.

7 Measure the circle artifact at the new magnification, and enter the X and Y positions of the new circle feature shown in the DRO into the Parcentric Offset X and Y fields of the Magnification setup screen.

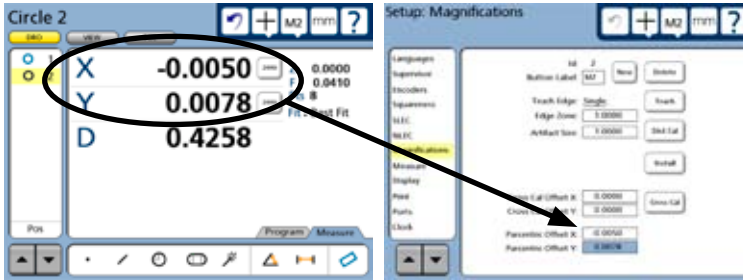

Enter the X and Y values of the circle at the new magnification...

into the X and Y Parcentric Offset data fields

8 Repeat steps 5 through 7 for the remaining magnifications.

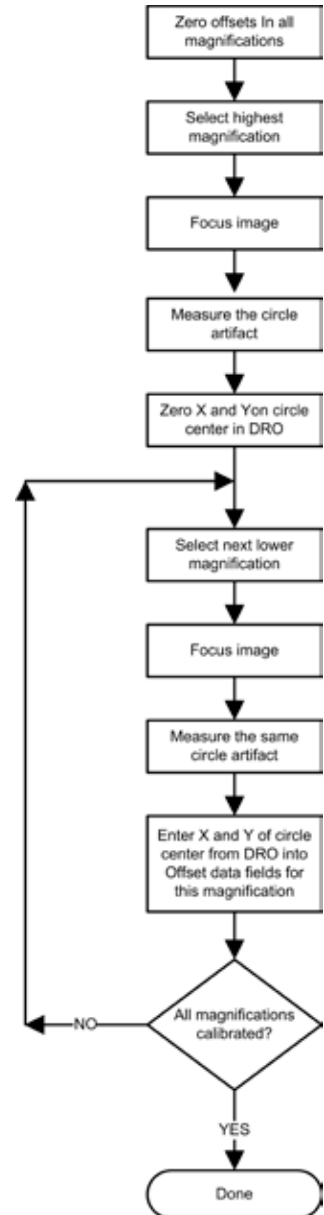

Measure screen

The Measure screen contains fields for specifying the method of data point collection, specifying the minimum number of points required to measure different geometries, locking the reference frame, selecting distance presentations and configuring point filtration.

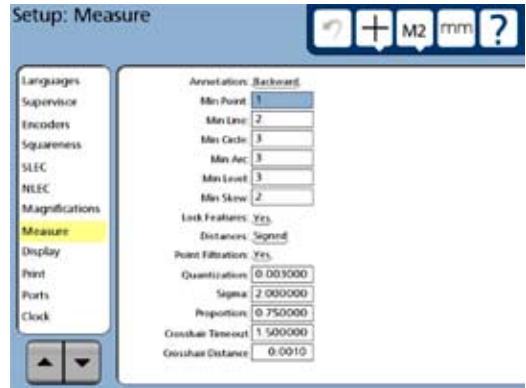

Annotation

The annotation type defines the method of data point collection. The annotation choice field can be toggled between Backward and Forward types.

Backward annotation imposes no limit on the number of data points that can be collected by the user when measuring a feature. For example, when backward annotation is used, a circle can be measured with as few as the minimum number of points shown in the Min Circle data field, or as many as the user wishes to collect up to a maximum of 99 points. When backward annotation is used, the user must press the Finish key to complete the measurement and store measurement data in the feature list.

Forward annotation limits the number of data points collected in a feature measurement to the minimum shown in the corresponding Min data field. For example, when forward annotation is used and the Min Circle value is 3, the circle measurement will automatically be completed when 3 points have been collected. No user interaction will be required to store the measurement data in the feature list.

Touch the Annotation choice field to toggle the choice between Backward and Forward annotation.

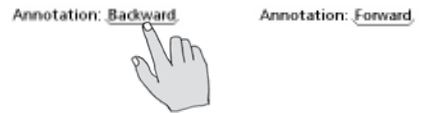

Minimum points required for a feature measurement

Each feature type is given a minimum data point requirement. The default minimums are the geometric minimums necessary to define the corresponding feature type. For example, a minimum of 3 points is required to define a circle, 2 for a line and 1 for a point. The minimum number required by the system can be increased (up to 99) to improve the accuracy of measurements. This is most useful when Forward annotation is used and the measurement data are automatically limited to the specified minimum.

To define the minimum data points required by the system to complete a feature measurement, touch the corresponding Min data field and enter the desired minimum number using the number keys.

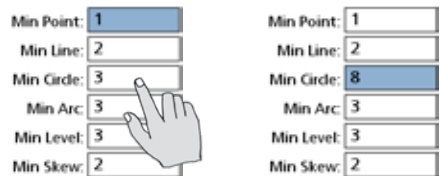

Locking features to their original datums

Features can be locked to their original datums or can be referred to new datums as datums are created. In the following example illustrating locked and unlocked features, 6 features are measured using 2 datums.

Measurement activity

Datum 1 is created, then

Feature 1 is measured, feature 2 is measured and feature 3 is measured

Datum 2 is created, then feature 4 is measured, feature 5 is measured and feature 6 is measured

Measurement results when features were locked before measurements

Features 1-3 are referred to datum 1

Features 4-6 are referred to datum 2

Measurement results when features were not locked before measurements

Features 1-6 are referred to datum 2

To lock features to their original datums, touch the Lock Features choice field to toggle the choice to Yes.

Lock Features: No

Lock Features: Yes



Specifying signed distances

Distance measurements result in X, Y and L (vector) displacements. The Y-axis displacements can be shown as signed or absolute (positive only) values. When signed values are specified, axis displacements from right to left and from top to bottom are negative.

To specify signed distances, touch the Distances choice field to toggle the choice to Signed.

Distances: Absolute

Distances: Signed



Enabling and configuring point filtration

Point filtration extracts aberrant data points from the total population of data during the least squares best fit calculations of arc, circle and line features. Points are extracted when they exceed the specified error limit (quantization factor) and fall outside the specified standard deviation range (Sigma factor). The filtration process ends when all remaining data points satisfy the quantization or standard deviation requirement, or when the minimum percentage of retained data points (proportion factor) is reached. Extracted data points are highlighted in yellow in the View window. The last points retained are highlighted in red.

Enabling point filtration

Touch the Point Filtration choice field and toggle the choice to Yes to enable point filtration.



Specifying a filtration error limit

The quantization factor is the maximum acceptable error. For most measurements, a quantization factor of 3 microns or less can be applied. However, measurements that contain larger numbers of aberrant points might benefit from higher quantization factors.

Touch the Quantization data field and enter the desired error limit.

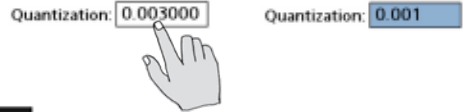
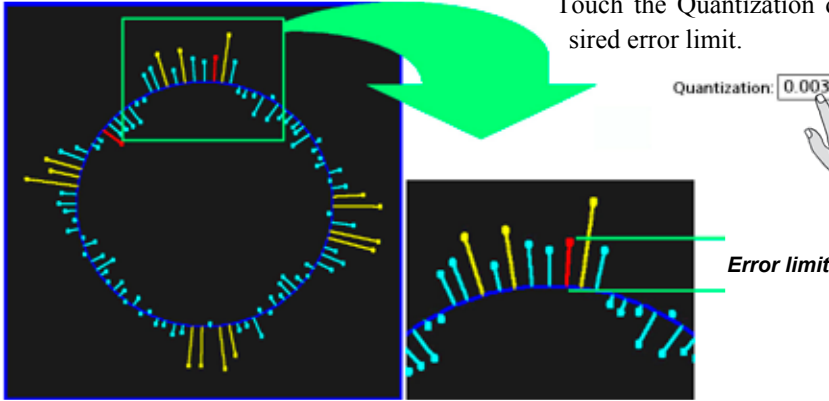

Specifying a filtration standard deviation range

The acceptable standard deviation range is determined by the value of Sigma. For example, a Sigma of 2.0 produces a Standard deviation range that includes 95.5% of the total population.

For most measurements, a Sigma of 2 or more can be applied. However, measurements that include a large number of aberrant points might benefit from a lower Sigma.

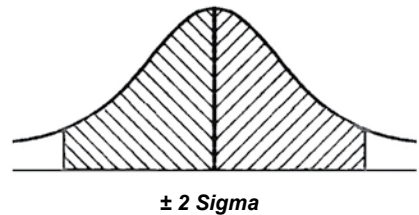
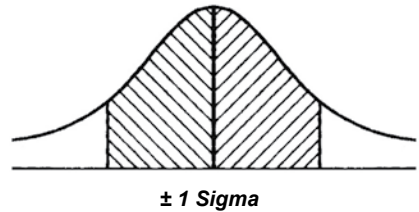

Touch the Sigma data field and enter the desired value.

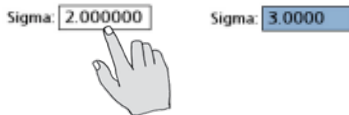

Specifying the minimum percentage of retained points

The Proportion value determines the minimum percentage of data points that will be retained. For example, a Proportion value of 0.75 will cause the system to retain a minimum of 75% of all data points collected for a feature.

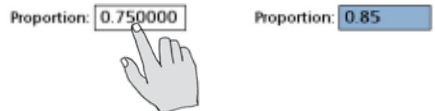

Touch the Proportion data field and enter the desired value.

Crosshair timeout delay

When the auto-enter crosshair probe is used, a point is automatically collected by the system each time the stage is moved to position the part under the crosshair. This automatic point entry is delayed until the stage has been motionless for a short time to ensure that the crosshair is located where the user intended. The default delay value will be adequate for most applications, but can be increased to accommodate more relaxed probing.

To specify Crosshair Timeout, touch the Crosshair Timeout data field and enter the desired delay in seconds.

Crosshair Timeout

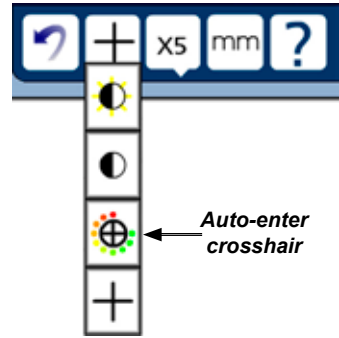

Crosshair delay restart distance

As explained above, automatic point entry is delayed until the stage has been motionless for a short time to ensure that the crosshair is located where the user intended. However, the delay is restarted again from the beginning if the stage is moved again before the delay has been completed. The move distance required to restart the delay is specified by the user by entering it directly into the Crosshair Distance data field in the current unit of measure.

Crosshair Distance

Display screen

The Display screen contains fields for configuring display resolution and other LCD display parameters.

Display resolution

The display resolution fields are used to specify the resolution of measurements shown on the DRO and other screens. Displayed numbers will be rounded as the display resolution is decreased below that of the input. The table below illustrates how the display is governed by the display resolution setting.

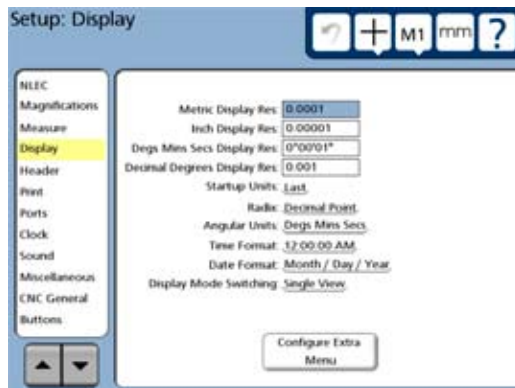

Encoder input	Display resolution	Displayed value
1.567	0.0001	1.5670
1.567	0.001	1.567
1.567	0.01	1.57
1.567	0.1	1.6
1.567	1	2



NOTE

Display resolution should never be higher than the encoder resolution. Specifying display resolutions that are higher than encoder resolutions can lead to misleading displays of values.

To specify display resolution, touch the data field of the desired Display category and enter the desired resolution using the number keys.

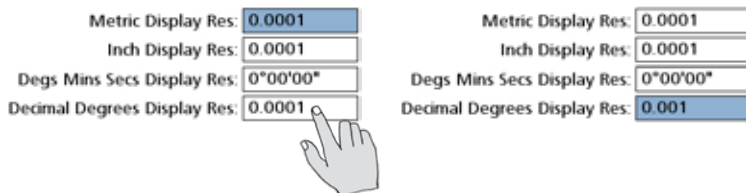

Default units of linear measure

The Startup Units field is used to specify the default display of linear measurements when power is applied to the system. These display settings can be changed temporarily but will revert to the startup defaults when the power is cycled.

To select startup units of linear measure, touch the Startup Units choice field to toggle between Inch and mm.

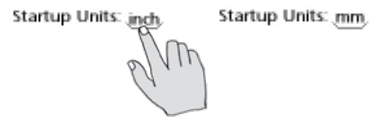

Radix for numeric displays

The Radix choice field is used to specify the radix displayed in numeric fields. Touch the Radix choice field to toggle between Decimal Point (1.0) and Comma (1,0).

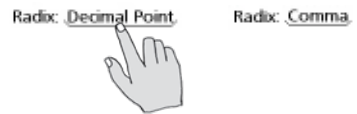

Angular units of measure

The Angular Units choice field is used to specify the display of angular units of measurement. The display choice can be toggled between degrees, minutes and seconds or in decimal degrees and will be retained across power cycles.

Touch the Angular Units choice field to toggle between degrees, minutes and seconds and decimal degrees.



Time formats

The Time Format choice field is used to specify the display of time. The display choice can be toggled between 12 hour and 24 hour formats and will be retained across power cycles.

Touch the Time Format choice field to toggle between 12 hour and 24 hour formats.



Date formats

The Date Format choice field is used to specify the display of date. The display choice can be toggled between Month/Day/Year and Day/Month/Year formats and will be retained across power cycles.

Touch the Date Format choice field to toggle between Month/Day/Year and Day/Month/Year formats.



Display mode switching

The QC-300 provides two display modes for measurements, Single View and Dual View.

In the Single View mode, the screen used for a measurement will be displayed again when the measurement is complete.

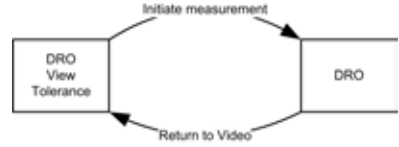

In the Dual View mode, the last screen used for a measurement will be used again for the current measurement. When the measurement is complete, the screen displayed before the measurement was initiated will be displayed again.

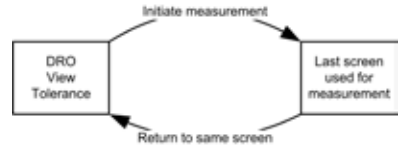

Touch the Display Mode Switching choice field to toggle the display mode between Single View and Dual View.

Display Mode Switching: Single View

Display Mode Switching: Dual View



Configuring the Extra tab

The Extra tab can be configured to contain controls for transmitting measurement data, controlling CNC functions, performing datum operations and a variety of other functions. Up to 99 Extra tabs can be configured to be available on each system. Repeatedly touching the Extra tab cycles through the available configurations. This is especially useful when the user would like to use a large number of data transmission, CNC and other functions, and would like to group similar functions on separate Extra tabs.

Touch the Configure Extra Menu button to display the configuration window.

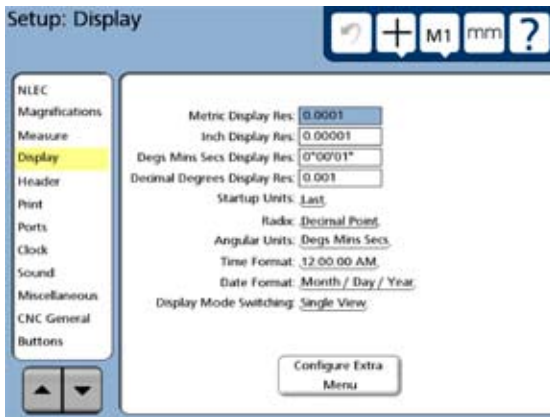

Touch the Configure Extra Menu button...

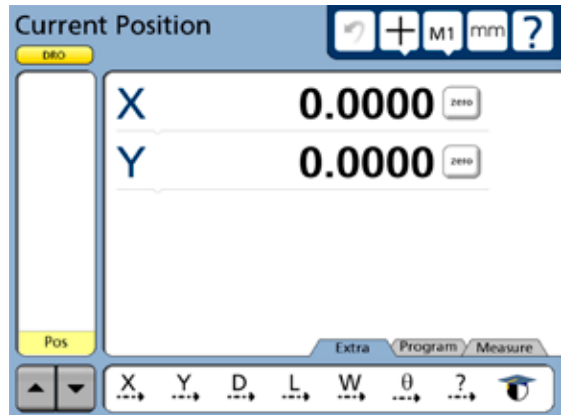

Extra tab at bottom of screen configured to contain controls for transmitting measurement data

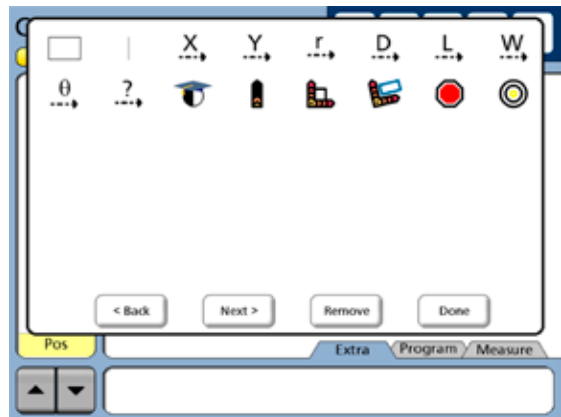

to display available Extra tab functions

Available Extra tab functions for your system and Extra tab editing controls are shown in the configuration window.



NOTE

Extra tab functions are different for different QC-300 systems. For example, Extra tab functions for a video edge detection QC-300 system will be slightly different than those for an optical edge detection system. Optional Extra tab functions also appear only in systems that include the corresponding options, such as laser pointers.

Extra tab functions

Space menu insert



The space insert are included in the Extra tab to separate control functions into groups on the tab.



Extra tab divided by space into data and CNC groups

Divider line menu insert

The divider line insert are included in the Extra tab to separate control functions into groups on the tab without using a space insert.

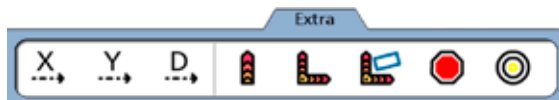

Extra tab divided by line into data and CNC groups

Data prompt function



The data prompt function is included in the Extra tab to send a user-defined measurement such as X position, Y position, radius or angle to the serial port, USB printer or USB drive as a file. When the user touches the data prompt function, a prompt message is displayed and the user selects the desired piece of measurement data to be transmitted.

Optical edge detector probe calibration (probe teach)



Teaching the edge detector calibrates it to correctly recognize dark to light transitions (edges) on the comparator screen. A teach calibration should be performed after each startup, whenever the part or magnification level changes or when the light conditions on the comparator change.

Joystick motor speed



The Joystick motor speed function is included in the Extra tab of systems with the CNC option to adjust the joystick control of motor speed. When the user touches the Joystick motor speed function, the joystick control of motor speed is toggled between fast and slow.



Fast



Slow

Axis lock



The Axis lock function is included in the Extra tab of systems with the CNC option to restrict stage motion to only one axis. When axis lock is on, motion is permitted only along one axis; diagonal motion is not permitted. When the user touches the Axis lock function, axis lock is toggled on or off.



Axis lock on



Axis lock off

Part following



The Part following function is included in the Extra tab of systems with the CNC option. Part following changes the motion reference from the machine coordinate system to the part coordinate system after a part skew has been performed. For example, if a skew is



Part following on



Part following off

performed along the part's X-axis, when part following is enabled, subsequent X-axis motion will follow the part skew, not the machine coordinate's X-axis. When the user touches the Part following function, part following is toggled on or off.

Stop motion



The Stop motion function is included in the Extra tab of systems with the CNC option to stop all stage motion. When the user touches the Stop motion function, motion is toggled on or off.



***Motion
stopped***



***Motion
enabled***

Goto feature



The Goto feature function is included in the Extra tab of systems with the CNC option. When the user touches the Goto function, the stage is moved to position the probe over the feature currently selected in the feature list.

Header screen

The Header screen contains fields for formatting text headers for printed and exported reports.



Creating report headers

Two columns of three text headers can be created for the top left and right sides of reports, as shown in this example. To create a header:

- 1 Touch the desired header field. The text entry window will be displayed.
- 2 Enter the text header and press the Enter button when finished.

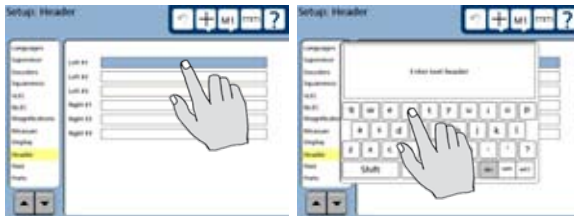

QC300 Feature Printout						
Left 1 Header text			Right 1 Header text			
Left 2 Header text			Right 2 Header text			
Left 3 Header text			Right 3 Header text			
Name	ID	Actual	Nominal	Minus	Plus	Dev
Lin 1	X	-0.5950	-0.5900	-0.5910	-0.5890	-0.0050
Lin 1	Y	-0.7100	-0.7050	-0.7150	-0.6950	-0.0050
Lin 1	f	0.0000	0.0000	0.0000	0.0001	0.0000
Cir 2	X	1.0683	1.0700	1.0650	1.0750	-0.0017
Cir 2	Y	0.3222	0.3250	0.3200	0.3300	-0.0028
Cir 2	D	0.4394	0.4400	0.4390	0.4410	-0.0006
Cir 2	f	0.0054	0.0000	0.0000	0.0050	0.0054

Print screen

The Print screen contains fields for formatting printed reports and RS232 data streams of feature measurement data.

Specifying a data type

The Print button initiates the transfer of data to the USB port for printing, or to the RS232 serial port for communication with a computer. Specify the type of data to be transmitted by repeatedly touching the Print Button choice field.



Data choices include:

- None No data will be printed or transmitted
- Select User will be prompted to select the data that will be printed or transmitted
- Report A standard report of all feature data or a tolerance report of only features that have tolerances applied will be printed or transmitted



Specifying a data destination

Feature measurement data can be sent to the USB port for printing, to the RS232 serial port for transmission to a computer or to the USB drive as a text file. Touch the Destination choice field to cycle through the destination choices.



Report Type

Report types are selected to send standard or tolerance reports to printers or a comma separated variable data file to a computer. Touch the Report Type choice field to cycle through the choices.

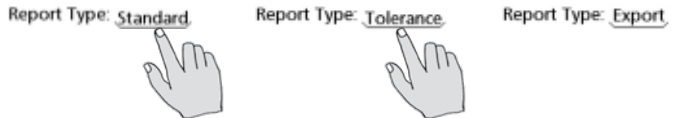

Lines per page

Specify the length of printed report pages by touching the Lines per Page data field and entering the desired number of character lines using the number keys.

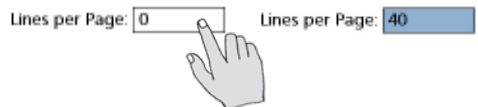

Specifying column separators

Columns of feature measurement data in printed reports and in transmitted data can be contiguous or can be separated by dividing lines, commas or Tabs. Touch the Column Separator choice field to cycle through the choices.



RS232 control characters

Control characters can be added to the beginning and end of line and form data streams to accommodate the requirements of receiving systems and programs. To add RS232 control characters, touch the desired data field and enter the ASCII character number using the number keys. Use the decimal point key to separate ASCII characters.



NOTE

An ASCII character chart is provided in [Chapter 9: Communication](#).

Selecting a USB printer

Touch the Printer choice field to cycle through the available USB Printers.

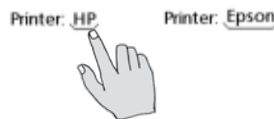

Ports screen

The ports screen contains fields for configuring the RS-232 serial communication port. The RS-232 communication port is used to send data to computers. RS-232 port settings can be changed to match those of the receiving system.

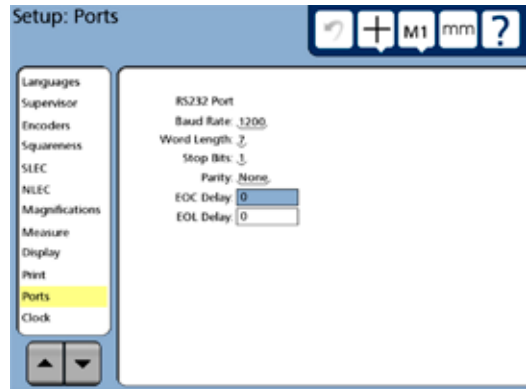

Baud rate

Touch the Baud Rate choice field repeatedly to cycle to the desired serial data rate. Baud rates from 1,200 to 115,200 are available.

Baud Rate: 1200 Baud Rate: 115200



Word length

Touch the Word Length choice field to toggle between data word lengths of 7 bits and 8 bits.

Word Length: 7 Word Length: 8



Stop bits

Touch the Stop Bits choice field to toggle between 1 and 2 stop bits at the end of the data word.

Stop Bits: 1 Stop Bits: 2



Parity

Touch the Parity choice field repeatedly to cycle to the desired parity error checking. Choices include None, Odd and Even.

Parity: None Parity: Odd



EOC delay

A delay can be inserted at the end of each character to satisfy the communication requirements of receiving systems. Touch the EOC data field and enter the desired delay in milliseconds using the number keys.

EOC Delay: 0 EOC Delay: 330



EOL delay

A delay can be inserted at the end of each line of characters to satisfy the communication requirements of receiving systems. Touch the EOL data field and enter the desired delay in milliseconds using the number keys.

EOL Delay: 0 EOL Delay: 250



Clock screen

The clock screen contains fields for setting the date and time included in data transmissions and printed on reports.

To change a date or time value, touch the desired choice or data field and enter the desired value.

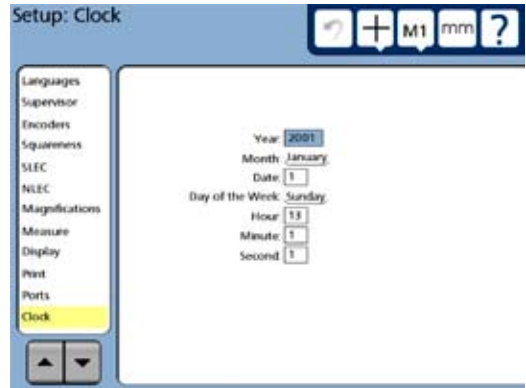

Year: Year:



Touch and enter numbers

Month: October Month: November



Touch and cycle through choices

Sound screen

A sound can be generated by the system to call attention to point entries. The sound is generated each time the Enter button is pressed to enter a point as part of a measurement.

Touch the Volume data field and enter a number to adjust the loudness of all sounds from 1 (very soft) to 10 (loud). Enter a zero to mute all sounds.

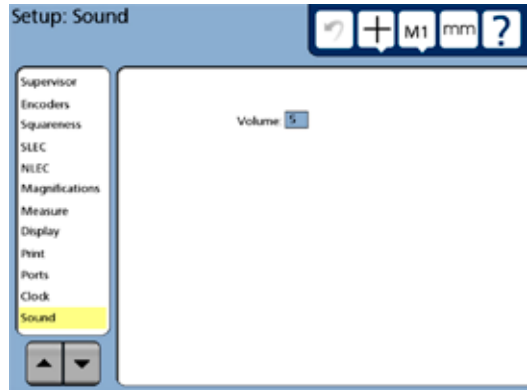
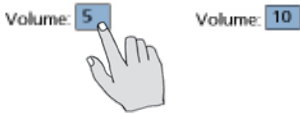

Miscellaneous screen

The Miscellaneous screen contains fields for calibrating and configuring the LCD touchscreen.

Return to DRO threshold

The display automatically switches to display current position on the DRO from the View, Tolerance or DRO screens when the stage movement reaches or exceeds the DRO threshold value.

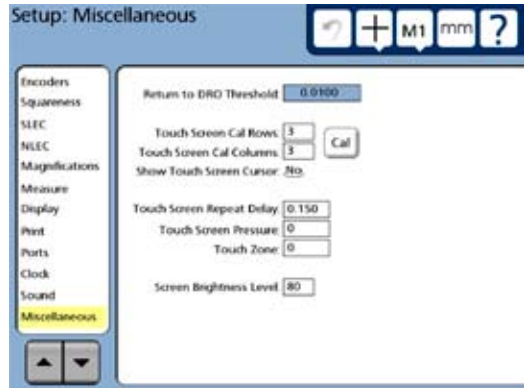

Touch the Return to DRO Threshold data field and enter the desired stage threshold motion using the number keys.

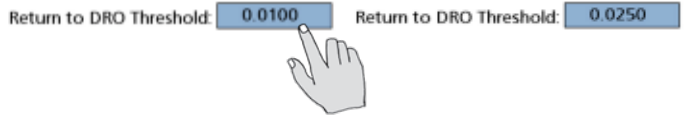

NOTE
Entering a zero disables this function.

Touchscreen calibration rows and columns

Touchscreen calibration measures touch-pressure at points displayed on a matrix of rows and columns. The number of touch-points included in the calibration is defined by specifying the number of rows and columns in the matrix. An example of a 4-row, 4-column matrix is shown at the right.

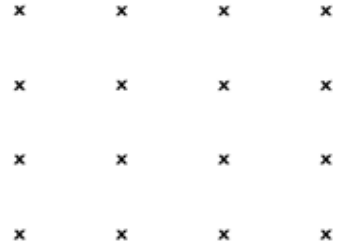

Example of a 4 X 4 calibration matrix

Touch the Touchscreen Cal Rows or Touchscreen Cal Columns data field and enter the desired value using the number keys.

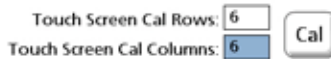
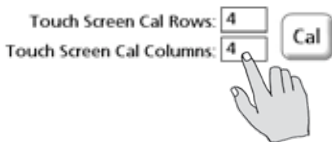

Calibrating the touchscreen

The touch-pressure of the touchscreen should be calibrated as part of the initial setup and when a new operator begins using the system. To calibrate the touchscreen:

1 Confirm that the number of calibration rows and columns provide adequate touch-points to satisfy typical use requirements. Increase or decrease them if desired as described above.

2 Touch the Cal button. The first point of the calibration matrix will be displayed.

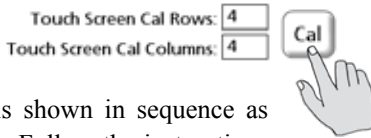

Each touch-point is shown in sequence as an x on the screen. Follow the instructions provided on the screen and then press the Finish key to complete the calibration. The touchscreen pressure calibration value will be shown in the Touchscreen Pressure data field.

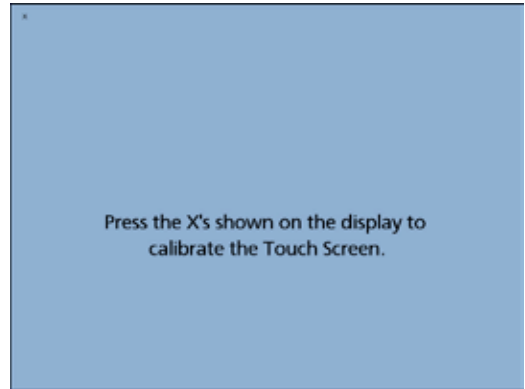

Touch screen cursor

A green cross mark cursor can be displayed on the touchscreen briefly to indicate the touch-point as visual feedback for the user.

Touch the Show Touch Screen Cursor choice field to toggle the choice between Yes and No.



Touch screen repeat delay

The feature list can be scrolled by touching and continuously pressing the scroll arrows at the bottom of the list. The scroll rate is inversely proportional to the touch screen repeat delay. Small delays result in rapid scrolling, large delays result in slow scrolling. Adjust the scroll rate by touching the Touch Screen Repeat Delay data field and entering the desired delay in milliseconds.

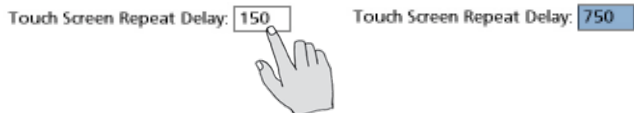

Touch zone size

The size of the touch zone can be changed to accommodate different users. When the touch zone size value is zero, the touch zone extends only to the limits of the choice or data field. As the touch zone value is increased, the touch zone is increased beyond the perimeter of the field on all sides. The touch zone value is expressed in screen pixels.

Show Touch Screen Cursor:

Default touch zone size

Show Touch Screen Cursor:

Enlarged touch zone size

To change the size of the touch zone, touch the Touch Zone Size field and enter the new value using the number keys.

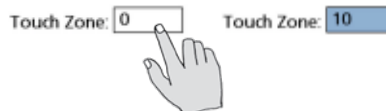

CAUTION

Increasing the touch zone size significantly might cause interference between adjacent fields.

Screen brightness

The LCD display brightness can be adjusted to accommodate different ambient lighting conditions.

To adjust brightness, touch the Screen Brightness Level data field and enter the desired value (min = 0, max = 100).

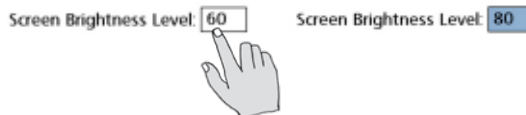

Showing the Extra tab

The Extra tab can be hidden or displayed at the bottom of the screen. To display the Extra tab, touch the Show Extra tab choice field to toggle the choice to Yes.

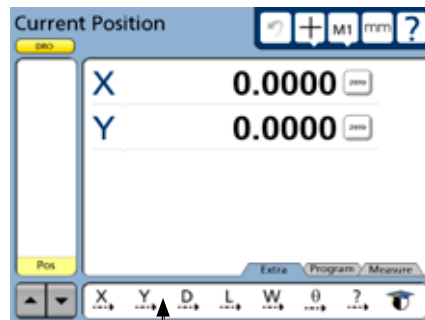
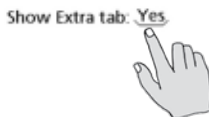

Extra tab at bottom of screen

Buttons screen

The Buttons screen contains fields for assigning frequently used QC-300 functions to joystick and foot switch buttons. Using preassigned buttons saves the time normally required to navigate menus. Each of the joystick and foot switch buttons can be assigned to functions shown in the choice fields. Thereafter, pressing the button invokes the assigned function.

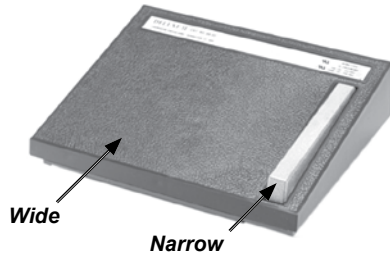
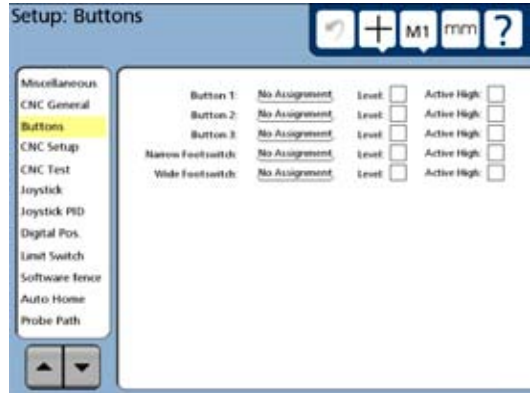
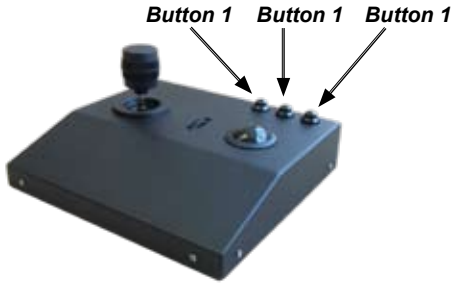

Selecting button functions

Button functions include:

- | | |
|---------------|---|
| No Assignment | Nothing happens |
| Enter | Enters data point |
| Finish | Completes a measurement |
| Cancel | Erases the last measurement point or erases a character |
| Quit | Quits a measurement |
| Axis Lock | Engages CNC axis lock - prevents diagonal motion |
| Speed toggle | Toggles the joystick speed between fast and slow |
| Go to Here | Performs CNC move to the selected feature |
| Part Follow | Engages CNC conversion from machine coordinates to part coordinates |

To select a button function, repeatedly touch the button's choice field until the desired function is displayed.

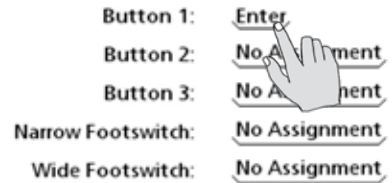

Selecting button responses

All button responses are either momentary or toggle. Momentary functions are level-based and are active only while the button is pressed and held. Toggle functions are activated when the button is pressed and released, and deactivated when the button is pressed and released again. Configure any of the button responses as momentary (level-based) by checking the button's Level box. Clear the Level box to configure the button response as toggle.



Selecting button logic

All button logic is either active high or active low. Configure each button to match the CNC amplifier input requirement by checking the Active High box for positive logic, or clearing it for negative logic.



Joystick screen

The Joystick screen contains fields calibrating and configuring overall joystick motion.

Enabling joystick motion

Check an axis Enable box to enable joystick motion, or clear the box to disable joystick motion on that axis.

Joystick



Enable: X Y

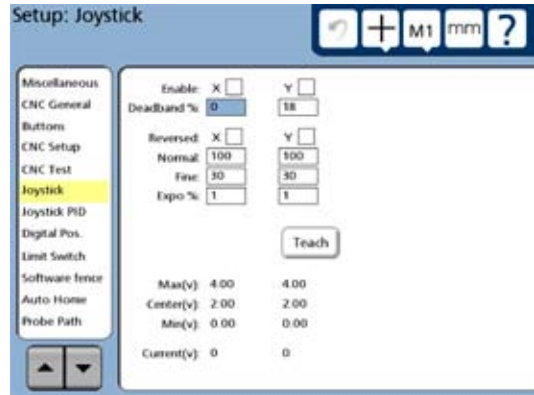

Specifying a joystick deadband

A deadband area of joystick inactivity is specified around the zero position of each axis to eliminate erroneous axis motion due to joystick vibration or noise. The default values are expressed as percentages of total motion and will satisfy the requirements of most environments, however these values can be increased or decreased by selecting the deadband field and entering the desired value.

Deadband %:



Specifying axis direction

The direction of motion controlled by the joystick on an axis is reversed to accommodate different joystick and system hardware by checking the Reversed axis box.

Reversed: X Y



Specifying normal and fine axis velocity

The normal and fine axis velocities controlled by the joystick are specified by selecting a Normal or Fine velocity field and entering the desired percentage of maximum axis velocity.

Normal:
Fine:



Specifying linear and nonlinear joystick motion control

The axis velocity controlled by the joystick is changed from linear to varying degrees of exponential by entering values into the axis Expo% fields. Expo % values are entered from 0 (linear) to 100 (very exponential). Two examples and a graph are shown below.

Linear example (Expo % = 0):

For each percent of Joystick displacement, the axis velocity increases a percent:

When the joystick is at 50%, the axis velocity is 50%

When the joystick is at 80%, the axis velocity is 80%

When the joystick is at 100%, the axis velocity is 100%

Nonlinear example (Expo % = 60):

At first, increased Joystick displacements do not cause the axis velocity to increase much, but then as the Joystick displacement continues to increase, the axis velocity increases at a higher and higher rates:

When the joystick is at 50%, the axis velocity is 20%

When the joystick is at 80%, the axis velocity is 25%

When the joystick is at 100%, the axis velocity is 100%

Select an axis Expo % field and enter the desired value.

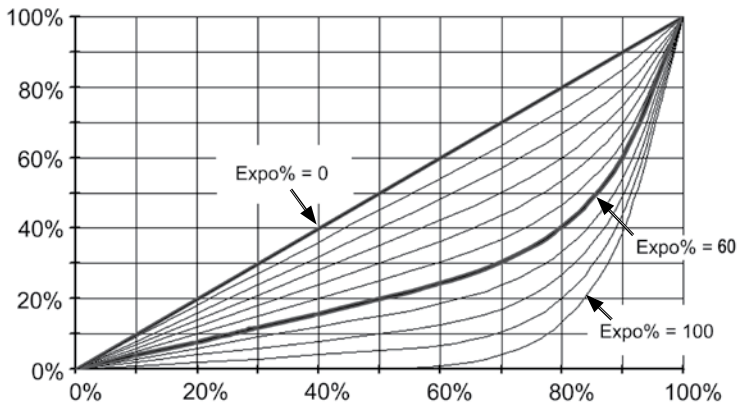
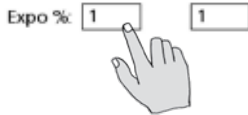

Calibrating the Joystick range of motion

The system must measure the joystick range of motion before the joystick can be used. Touch the Teach button to start the calibration procedure, and then follow the instructions displayed on the screen. Joystick positions will be indicated by Max(v), Center(v), Min(v) and Current(v) voltage values.

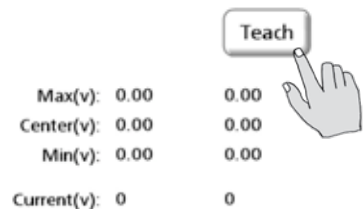

Digital positioner screen

The Digital positioner screen contains fields for calibrating and configuring digital positioner motion.

Enabling digital positioner motion

Check an axis Enable box to enable digital positioner motion, or clear the box to disable digital positioner motion on that axis.

Enable: X Y



Specifying axis direction

The direction of motion controlled by the digital positioner on an axis is reversed to accommodate different digital positioner and system hardware by checking the Reversed axis box.

Reversed: X Y



Specifying normal and fine axis velocity

The normal and fine axis velocities controlled by the digital positioner are specified by selecting a Normal or Fine velocity field and entering the desired percentage of maximum axis velocity.

Normal:
Fine:



Specifying axis acceleration

The axis acceleration controlled by the digital positioner is specified by selecting an axis field and entering the desired percentage of maximum axis acceleration.

Accel %:



Specifying a digital positioner counter debounce

An area of digital positioner inactivity is specified around the current rest position of each axis to eliminate erroneous axis motion due to digital positioner vibration or noise. The default values are expressed as positioner counts and will satisfy the requirements of most environments, however these values can be increased or decreased by selecting the Debounce Cnts field and entering the desired value.

Debounce Cnts:



Current value display

The axis current values change as the digital positioner is moved. This display is only provided as a convenience for the user.

Current Values: 0 0

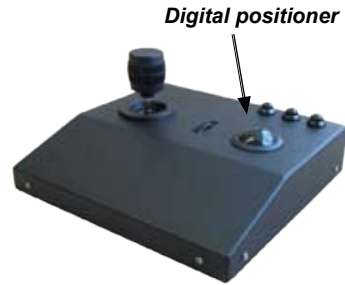
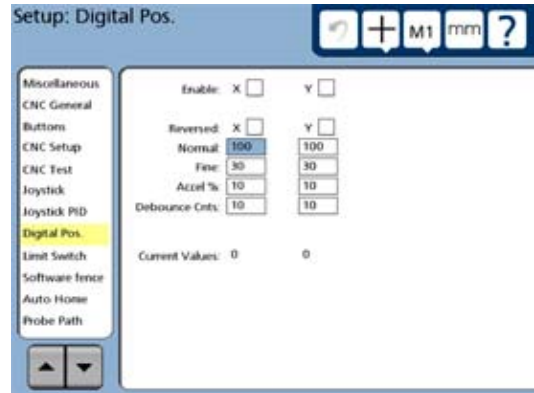

Probe path screen

CNC probing parameters are specified in the Probe path screen to control CNC probing and non-probing velocities as well as data point approach and search distances during program execution.

Probing and non-probing velocities

Transitions from one target edge to the next are made at relatively high non-probing velocities. When the approach distance from the edge is reached, the system velocity is reduced to the slower probing velocity. If the edge is not recognized at the anticipated point, the system continues searching at the probing velocity until the end of the specified search distance is reached. If no edge is recognized within the approach and search distances, an error message is displayed.



NOTE

In general, the best probing accuracy is obtained at lower probing velocities. However, since the system is accurate at higher velocities, the major

velocity consideration is related to the torque required to perform high acceleration and deceleration moves, and the resulting potential for measurement errors.

To specify probing and non-probing velocities:

- 1 Select the Probing Velocity % field and enter the probing velocity as a percentage of the maximum CNC velocity.
- 2 Select the Non-probing Velocity % field and enter the non-probing velocity as a percentage of the maximum CNC velocity.

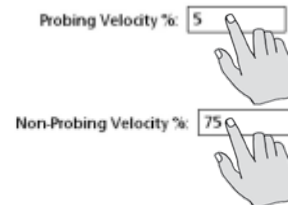
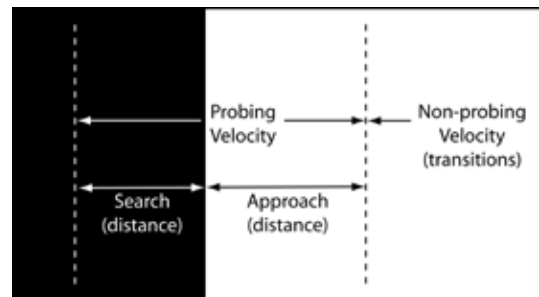
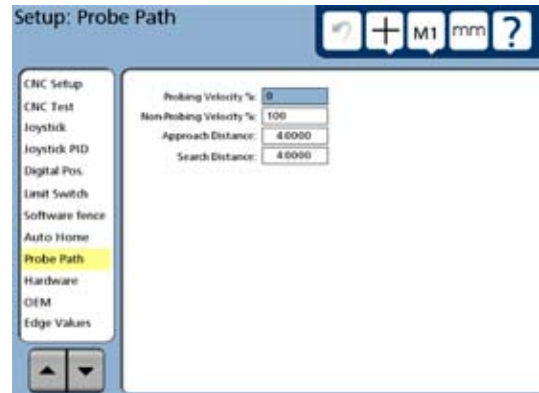

Approach and search distances

The probing velocity is maintained over the approach distance to the target data point. The approach distance should be large enough to allow the system to reach a constant probing velocity, and small enough to facilitate rapid measurement. The search distance extends the probe's travel in the event that the target data point is not found where it was expected. The search distance should be large enough to make the system less sensitive to acceptable target position variations and small enough to produce an error message when the target is outside acceptable position variations.

To specify the approach and search distances:

- 1 Select the Approach Distance field and enter the approach distance in the appropriate unit of measure.
- 2 Select the Search Distance field and enter the search distance in the appropriate unit of measure.

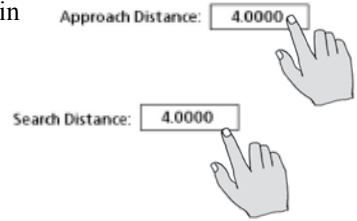

Edge values screen

The optical probe input from the edge detection circuit is debounced by time and distance to eliminate false edge indications due to noise and vibration. The Debounce time and distance must be non-zero values. Time is entered in seconds and distance is entered in the current unit of measure. The default values are adequate for the vast majority of applications, but can be replaced with higher values in noisy environments.

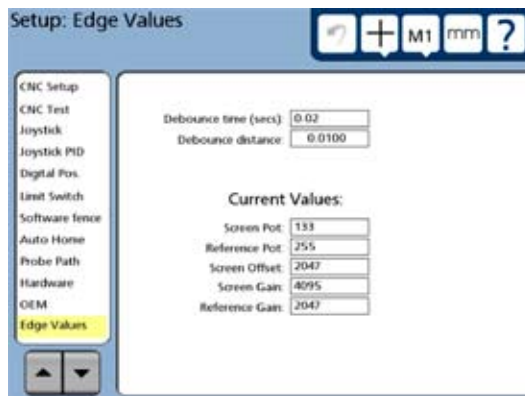

Debouncing edges

To specify optical edge debounce time and distance:

1 Select the Debounce time field and enter the debounce time in seconds.

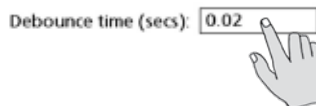

2 Select the Debounce distance field and enter the debounce time in the the appropriate unit of measure.

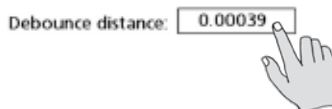

Viewing current edge detector values

The current edge detector values are displayed for informational and diagnostic purposes, and cannot be changed in this screen.

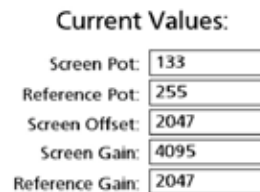

Hardware screen

The Hardware screen contains fields that describe the software and hardware configuration of your system. This information will be essential to Metronics technical support personnel if your system is upgraded or repaired.

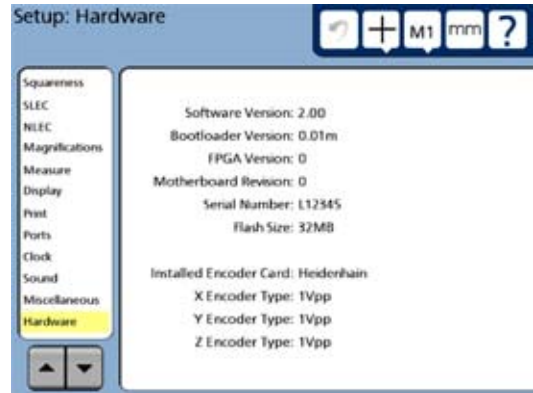

Chapter 11:

Problem Solving

The QC-300 is based on years of experience manufacturing the Metronics QC-100, QC-200 and QC-5000 products. Years of continuous improvement have resulted in extremely reliable operation and few, if any problems. Problems experienced with the operation of the QC-300 are likely to be the result of printer or cable incompatibilities, instrument configuration or setup errors, encoder incompatibilities or malfunctions or setup and calibration issues.

The steps recommended for initial troubleshooting are shown below. These are typically the same initial steps that would be taken by a distributor or factory product support technician.

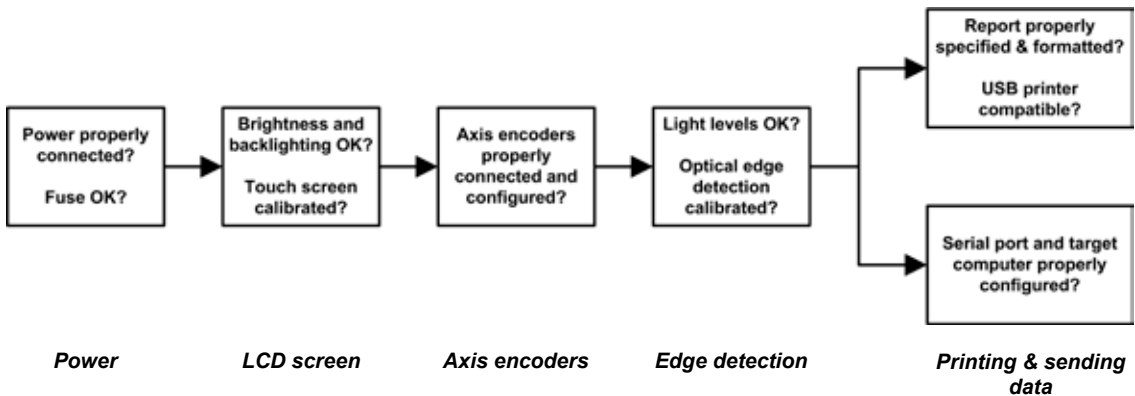

Since most problems experienced in the field will have simple causes, and equally simple solutions, substantial time and expense can be saved by performing some straightforward troubleshooting of configuration settings and hardware connections prior to calling the distributor or factory for assistance.

As you're troubleshooting, list the steps that you use to identify and solve your problem. Should problems persist in spite of your efforts, gather the product information listed at the end of this chapter, and your list of troubleshooting steps, and then contact your distributor for assistance.



NOTE

Confirm that the essential setup steps described in **Chapter 10: Setup** have been performed before troubleshooting or requesting assistance.

Symptoms, probable causes and solutions

Some common symptoms of problems are listed in the following pages with probable causes and possible solutions.

No image is visible on the LCD screen

Probable cause 1: *Power is not applied to the QC-300*

Possible solutions:

- 1 Activate the main power source.
- 2 Connect the power cord or turn the power ON.
- 3 Replace the fuse.

Probable cause 2: *LCD ON/OFF toggle switch is in the OFF mode*

Possible solution:

- 1 Press the LCD ON/OFF button to toggle the LCD ON.

Probable cause 3: *LCD contrast or backlighting is out of adjustment*

Possible solution:

- 1 Readjust the backlighting using the decimal point or +/- key.
- 2 Adjust the brightness level in the Miscellaneous setup screen.

Values displayed on the LCD screen are incorrect

Probable cause 1: *The axis encoder is not connected or is malfunctioning*

Possible solutions:

- 1 Connect the axis encoder cable firmly to the QC-300.
- 2 Replace the axis encoder.

Probable cause 2: *The Encoders setup screen specifies the wrong axis encoder resolution*

Possible solution:

- 1 Specify the correct resolution in the Encoders setup screen.

Probable cause 3: *The wrong axis encoder count polarity is specified in the Encoders setup screen*

Possible solution:

- 1 Specify the correct count polarity in the Encoders setup screen.

Probable cause 4: The wrong encoder is connected to the axis**Possible solutions:**

- 1 Connect the axis encoder specified in the Encoders setup screen.
- 2 Confirm that the each encoder is connected to the correct axis input.

Probable cause 5: The wrong in/mm unit of measure is specified**Possible solution:**

- 1 Specify the correct units of measure in the Encoders setup screen.

Probable cause 6: The wrong encoder reference mark is specified**Possible solution:**

- 1 Correct the reference mark type in the Encoders setup screen.

Probable cause 7: Error correction is required to compensate encoder inaccuracies:**Possible solutions:**

- 1 Perform LEC, SLEC or optional NLEC error correction in the corresponding error screen.
- 2 Error correction was performed but not enabled. Enable error correction in the LEC, SLEC or optional NLEC setup screen.

Probable cause 8: Edge detection is not calibrated:**Possible solution:**

- 1 Perform a Teach operation or a Distance Cal using the Magnifications Setup screen.

Probable cause 9: Edge detector and crosshair probes are not cross-calibrated:**Possible solution:**

- 1 Perform a Cross Cal using the Magnifications Setup screen.

Probable cause 10: Multiple system magnifications are not calibrated to be parcentric:**Possible solution:**

- 1 Perform a Parcentric calibration using the Magnifications Setup screen.

Reports are not printed or are incomplete

Probable cause 1: *The channel input device is not connected or is malfunctioning*

Possible solution:

- 1 The printer is not supported by the QC-300.

Probable cause 2: *The USB cable is not firmly connected or is damaged*

Possible solution:

- 1 Connect or replace the printer cable.

Probable cause 3: *The printed report setup is incorrect*

Possible solution:

- 1 Correct the report setup in the Print setup screen.

Probable cause 4: *The printer is not supported*

Solution:

- 1 Contact Metronics for a list of supported printers.

Reports are printed incorrectly

Probable cause 1: *The printed report setup is incorrect*

Possible solution:

- 1 Correct the report setup in the Print setup screen.

Probable cause 2: *The wrong control characters are specified*

Possible solution:

- 1 Correct the control character configurations in the Print setup screen.

Optical edge detection is not working properly

Probable cause 1: Reference or sensor light levels are incorrect

Possible solution:

- 1 Refer to *Evaluating optical light levels* in [Chapter 10: Setup](#) for instructions regarding light levels, and then reorient, repair or replace light sources or optical cables.

Probable cause 2: Edge detection is not calibrated:

Possible solution:

- 1 Perform a Teach operation or a Distance Cal using the Magnifications Setup screen.

Probable cause 3: Edge detector and crosshair probes are not cross-calibrated:

Possible solution:

- 1 Perform a Cross Cal using the Magnifications Setup screen.

Probable cause 4: Multiple system magnifications are not calibrated to be parcentric:

Possible solution:

- 1 Perform a Parcentric calibration using the Magnifications Setup screen.

Data cannot be transmitted to a computer

Probable cause 1: *The wrong serial cable (or no cable) is connected between the computer and the QC-300*

Possible solution:

- 1 Connect the computer to the QC-300 using an RS-232 serial cable that does not include crossed transmit and receive wires. The correct cable can be ordered from Metronics by specifying part number 11B12176.

Probable cause 2: *The wrong RS-232 port settings are specified*

Possible solution:

- 1 Correct the RS-232 port settings to match the computer's serial port settings in the Port setup screen.

Probable cause 3: *The wrong control characters are specified*

Possible solution:

- 1 Correct the control characters to reflect the requirements of the receiving software in the Print setup screen

Getting help from your distributor

Performing the simple troubleshooting listed on the previous pages solves most problems experienced with the QC-300. If a problem persists after performing this troubleshooting, follow the steps listed below and contact your distributor for assistance.

- 1 Be prepared to discuss your troubleshooting steps.
- 2 Gather the following QC-300 information:
 - Model number
 - Serial number
 - Approximate purchase date
 - Software version number and hardware information from the Hardware setup screen.

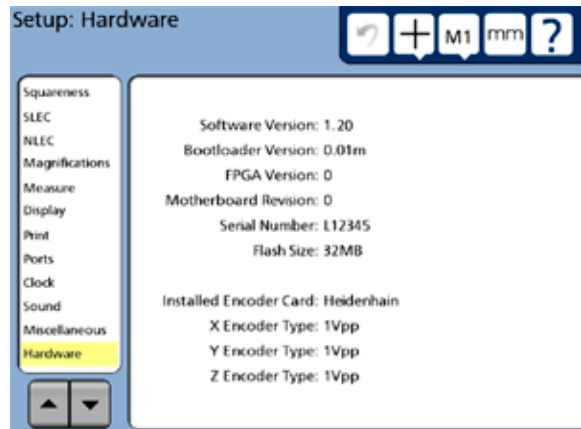

Chapter 12:

Reference Material

This chapter contains technical information regarding:

- QC-300 product specifications
- Footswitch wiring
- RS-232 connector wiring
- Tolerances

Product specifications

Electrical

Input Voltage Range: 85 VAC to 264 VAC. 1.0 Amp maximum (Auto switching)
 Fuse: 1.6 Amp 250 VAC Slow Blow 5 x 20 mm
 Input Frequency: 43 Hz to 63 Hz

Environmental

Temperature: 0 °C to 45 °C (32 °F TO 113 °F) non-condensing
 Humidity: 90% rh maximum
 Altitude: 2000 meters (6,562 ft) maximum
 Installation: Category: II

Dimensions

Enclosure (W x H x D): 29.2 cm x 19.1 cm x 7.0 cm (11.5" x 7.5" x 2.75")
 Base (W x H x D): 25.4 cm x 5.1 cm x 19.8 cm (10" x 2" x 7.8")
 Enclosure weight: 1.6 kg (3.5 lbs.)
 Base weight: 3.2 kg (7 lbs.)

LCD

Size/color: 17.2 cm (6.8 inch) x 12.9 cm (5.1 inch) TFT color touch screen
 Resolution: 800 x 600 pixels

ENC tests

EN61000-4-3, EN61000-4-4, EN61000-4-5, EN61000-4-6, EN61000-4-11, EN61000-4-2, EN61000-4-1

Footswitch wiring

The optional foot switch is connected to the RJ-45 connector on the left side of the QC-300.

The wiring of the footswitch is sometimes duplicated by other external switching devices to facilitate remote operation in conjunction with other devices in a larger semi-automated system.

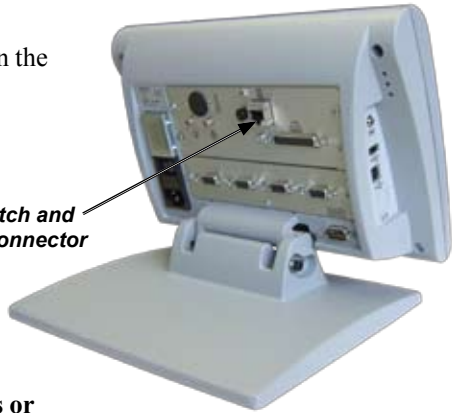

CAUTION

Never apply power to the footswitch wires. Applying power to the connector wires or wiring the switch connector in any way other than shown by this diagram can cause serious damage the QC-300 and void the product warranty.

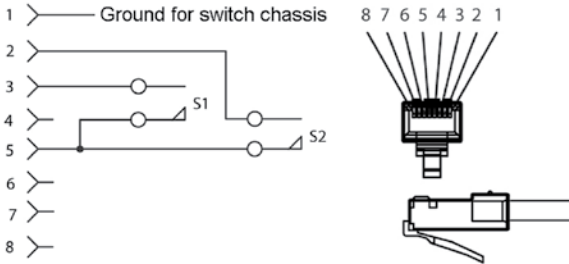

RS-232 connector wiring

The RS-232 wiring is shown by the table below.

Pin No.	Description	Direction
2	Data in	Input
3	Data out	Output
7	Signal ground	Reference
8	Power on	Output (always high)



Tolerances

The following information is supplemental to the tolerance discussions provided earlier in [Chapter 7: Tolerancing](#).

Concentricity tolerance

The mathematical definition of concentricity is explained in detail in the ASME Y14.5M-1994 standard and involves “the midpoints of opposing elements” in the determination of actual concentricity. This is not practical in a discrete point measuring system, so the QC-300 uses the center of the feature (determined by the best fit) to estimate the concentricity.

Reference Features

When a reference feature is called for in a tolerance definition, the reference feature will nearly always refer to a datum feature such as a skew line or datum circle. The field is required except for the MMC / LMC tolerance case.

Least squares best fit

Data is iteratively processed to position a perfect circle within the data cloud in the position that minimizes the sum of the squared form errors. Form errors are inside and outside the circle.

Maximum inscribed circle

First, a least squares best fit circle is estimated, then the data is iteratively processed to position a perfect circle through 3 points on the inside of the data cloud. The maximum inscribed circle position encloses the maximum diameter of the circle by the data cloud. Form errors are outside the circle.

Minimum superscribed circle

First, a least squares best fit circle is estimated, then the data is iteratively processed to position a perfect circle through a minimum of 2 points on the outside of the data cloud. The minimum superscribed circle position encloses the data cloud with the minimum circle diameter. Form errors are inside the circle.

ISO (least radial distance)

First, a least squares best fit circle is estimated, then the data is iteratively processed to position a perfect circle in the location that minimizes the inside and outside form errors. Form errors are inside and outside the circle.

Chapter 13:

Options

Available options for the QC-300 are listed and shown here with Metronics part numbers:

- Foot switch for remote operation
- RS-232 cable without crossed cable wiring for communication with computers
- Arm-mounting bracket and bracket adapter for mounting the QC-300 on vertical surfaces (must be ordered together)
- Taltech WinWedge© for inputting serial data directly from the QC-300 into any PC application

Contact the Metronics sales group by phone at 603.622.0212 or by e-mail at sales@metronics.com to order QC-300 options.

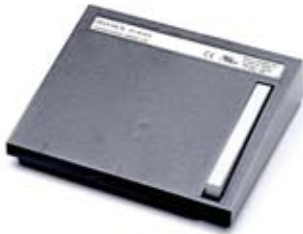

Foot switch w/8 ft cable
11B12816



Serial cable
11B12176



QC arm-mounting bracket
38-22-60-101



QC arm-mounting bracket adapter
11D12764



Taltech WinWedge software
54-775-005

INDEX

Symbols

.acf files 181
 2-Wire 6
 2-Wire to 3-wire adapters 6
 3-Wire 6
 3-Wire adapters 6

A

About screen 169
 Absolute reference marks 173
 Acceleration, axis 214
 Adding video magnifications 186
 Alignment, skew 31
 Altitude, specification 225
 Angle
 Constructions 119
 Tolerance 136
 Angles 60, 69
 Angular units of measure 196
 Annotation
 Backward 61
 Type 191
 Approach distance 216
 Arc constructions 118
 Archiving and retrieving programs 153
 Arcs 60, 64, 131, 132
 Arm-mounting bracket 229
 Artifact, calibration 175
 ASCII code table 162
 ASME Y14.5M-1994 standard 125
 Assistance, getting 219
 Auto-enter function 194
 Automatic point entry 44
 Axis choices 172
 Axis encoders 7

Axis error messages 174

B

Backlighting 220
 Backup battery 164
 Backward/forward annotation 61
 Backward annotation 61, 191
 Baud rate 204
 Best-fit algorithm 65, 125
 Bidirectional tolerance 130
 Bits
 Data 157
 Stop 157
 Bolt holes 3
 Bonus 133
 Bore 133, 134
 Boss 133, 134
 Bracket, QC-300 mounting 229
 Bracket adapter, QC-300 mounting 229
 Brightness, LCD display 209
 Buttons
 Command 20
 Foot switch 210
 Front panel 13
 Joystick 210

C

Calibration
 Crosshair and edge probe offset 188
 Distance 47
 Edge detector 47
 File, NLEC
 NLEC by adjusting station values 184
 NLEC from features 182
 Probe cross calibration 47
 Squareness of the measuring system 175
 Touchscreen 208
 Cancel 20
 Category, omitting a tolerance 129
 Characters, RS-232 control 203

- Circle
 - Constructions 115
 - Maximum inscribed 228
 - Measuring a 35
 - Probing 65
 - Minimum superscribed 228
- Circles 60, 65, 131
- CNC 1, 10, 18, 145
- Columns, calibration rows and 207
- Communication 157
- Computer 8, 157, 158
- Concentricity 228
- Concentricity tolerance 135, 228
- Conditions, lighting 209
- Configuration 163
- Connecting
 - Axis encoders 7
 - CNC outputs 10
 - Computer 8, 157
 - Footswitch 9
 - Optical edge detector inputs 9, 10
 - Printer 8, 159
- Connector, RJ-45 226
- Constructing a datum zero point 56
- Contrast 46, 209, 220
- Control, joystick motion 213
- Control characters 222, 224
- Correction
 - Error 176
 - Linear error 176
 - Nonlinear error 181
 - Segmented linear error 178
 - Text file 185
- Count direction 174
- Creating
 - Arc 123
 - Circle 122
 - Datum zero point 32
 - Line 122
 - Point 121
 - Rectangle 124
 - Slot 123
 - Creating features 121
 - Creating programs 139
 - Cross calibration 47
 - Crosshair and edge probe offset 188
 - Crosshair delay restart distance 194
 - Crosshair probes 1, 43, 44 50
 - Crosshairs and optical edge detection 61
 - Crosshair timeout delay 45, 194
- Cursor 208
- D**
 - Data
 - Destination 202
 - Printing feature measurement 160
 - Required to complete a measurement 191
 - Sending 16
 - Type 202
 - Date 205
 - Date formats 196
 - Datum 29, 142, 192
 - Datum zero point 55, 56
 - Deadband, joystick 212
 - Debounce, digital positioner counter 214
 - Delay 45, 194
 - Delay, EOC 157
 - Delay, EOL 157
 - Delay restart distance 194
 - Deleting
 - Feature data 27
 - Programs 155
 - Setup data 166
 - Video magnifications 186
 - Demonstration, quick start 29
 - Descriptions, setup screen 169
 - Direction 174
 - Direction, axis 212, 214
 - Displayed language 169
 - Display resolution 195
 - Display the tolerance screen 127
 - Distance 194

Distance), iso (least radial 228

Distance

Approach 216

Calibration 47

Constructions 98

Debounce 217

Search 216

Distances 60, 68, 192

Distributor, contacting 224

Drive

Copy to 15

Select a 15

DRO 22

DRO threshold 207

Dual view mode 197

E

Ear phones 2

Edge calibrations

For difficult measurements 187

For routine measurements 187

Teach 47

Edge detector 9, 43, 48, 61, 188, 219, 223

Edge detector reference and sensor light levels 46

Edge probe offset 188

Edges, debouncing 217

Editing

Existing program steps 146

Magnifications 146

Electrical specifications 225

Electrical wiring and connections 6

Encoder

Count direction 174

Resolution 172

Type 172

Encoders 7

ENC tests 225

Enter 20

Entering and deleting setup data 166

Entry, automatic point 48, 50

Entry, manual point 48, 49, 50

Environmental specifications 225

EOC delay 204

EOL delay 204

Error

Correction 47

Messages 174

Essential setup requirements 168

Export results 29

Extra tab 16, 199

F

Feature

Constructing 70

Goto 19, 200

Measuring 35, 142, 191

Feet, mounting 3

Fiber-optic cables 9

Fields

Choice 172

Data entry 172

Filtration, point 192

Finish 20

Fixturing 145

Following, part 19, 199

Footswitch 3, 9, 229

Footswitch wiring 226

Forward annotation 61, 191

Front panel keys 2

Functions

Button 210

CNC and other extra tab 18, 199

Data prompt 18, 199

LCD screen 22

Measurement 14

Programming 15

System 24

Fuse 225

G

Getting help from your distributor 224
Grid, NLEC 181, 184

H

Hard stop 173
Hardware setup screen 224
Headers, report 201
Help 224
Here, goto 15
Hiding setup parameters 170
Humidity 225

I

Icons 14
Importing an existing NLEC text file 185
Initial troubleshooting 219
Input
 Frequency 225
 Voltage range 225
Insert
 Divider line menu 18, 199
 Space menu 18, 199
Interface, user 13

K

Keys
 Command 20
 Number 23
 Wide 20

L

Labeling axes on display printouts 203
Language 169
LCD 225
 Contrast or backlighting 220
 On/off 27
 Screen 220, 225

LEC (linear error correction) 176
LEC or SLEC, which is right for me? 176
Leveling the part (optional) 53
Lighting 46
Light levels 46, 188
Lightning 7
Limit, filtration error 193
Limiting access to program functions 170
Line constructions 79
Lines 60, 63, 130, 132
List, feature 21
LMC tolerances 133
Loading settings 171
Lock
 Axis 18, 199
 Programs 165, 170
Logic, button 211

M

Machine zero reference 174
Magnification 24, 46
Manual
 Point entry 44
 Reference mark 173
Measure magic 58
Measurement
 Activities 1, 51
 Axis choices 172
 Errors 215
 Part features 29, 35, 58
 Process 52
 Reference 53
Menu 13, 164
Message 15, 141, 149, 174
Metronics QC Quickie slide 29
Minimum
 Points required for a measurement 191
 Setup requirements 168
Misaligned parts 1, 31, 54
Miscellaneous screen 207, 217

MMC and LMC tolerances 133
 MMCcircles and arcs 133
 Mode, edit 15
 Motion
 Calibrating the joystick range of 213
 Digital positioner 214
 Joystick 212
 Stop 19, 200
 Mounting stand 6
 Moves, CNC program 15

N

New program steps 150
 NLEC (nonlinear error correction)
 Calibrating 184
 Calibration data 184
 Correction text file 185
 Screen 181
 Text file 181
 Noisy environments 2
 Nonlinearities 176

O

Offset 188
 On/off
 Laser pointer 18, 199
 LCD 27
 Operating parameters of the QC-300 163
 Optical
 Cables 9
 Edge detection 29, 43, 61, 223
 Edge detector inputs 9, 10
 Input jacks 9
 Light levels 188
 Options for the QC-300 229
 Original datums 192
 Overview 1

P

Page, lines per 202
 Parallelism tolerances 136
 Parallel port configuration 222
 Parameter choices 166
 Parcentric calibrations 189
 Parity 157, 204
 Part condition 46
 Part fixturing 145
 Part level 1
 Part misalignment 54
 Pass/fail results 38, 128
 Password 165, 170
 Permanent part fixturing 145
 Perpendicularity tolerance 136
 Point
 Constructing a datum zero 33
 Constructions 70
 Creating a datum zero 32, 55
 Entry 44
 Probing a datum zero 32
 Points 60, 62, 130
 Points
 Retained 193
 Required for a feature measurement 191
 Port
 Com 157
 RS-232 serial 26, 157
 Position tolerances 132
 Power
 Cord and plug 6
 Line transients 7
 Surge suppressor 7
 Preparing to use probes 46
 Print
 Button 202
 Feature measurement data 160
 Report 26, 160
 Report of the QC-300 setup parameters 161

- Printer 8, 159
- Printer
 - USB 203
 - Format strings 159
- Probe
 - Crosshair 50
 - Edge detection 48
 - Screen 43
 - Select a new 30
 - Offset 188
 - Preparing to use 46
 - Velocity 215
- Probes 24, 43, 44
- Probing
 - Accuracy 215
 - Angles 69
 - Arcs 64
 - Circles 65
 - Datum zero point 55
 - Distances 68
 - Lines 63
 - Multiple specific feature type 59
 - Points 62
 - Process 60
 - Rectangles 67
 - Slots 66
 - Specific feature types 59, 62
 - With crosshairs 50, 61
 - With optical edge detection 61
 - With edge detectors 48
 - With measure magic 58
- Problem solving 219
- Product specifications 225
- Program
 - Copying 15
 - Creating 139
 - Deleting 155
 - Record 15, 140
 - Run 15, 41
 - Saving and retrieving 153
 - Editing 146
 - Functions 170
- Q**
 - QC-300
 - Mounting the 229
 - Version information 224
 - QC Quickie slide 29
 - Quit 20
- R**
 - Radix for numeric displays 196
 - Range, filtration standard deviation 193
 - Rate, baud 157
 - Recording
 - Program 140
 - Stop program 40
 - Rectangles 60, 67, 131
 - Reference
 - Cable connector 9
 - Create part skew and datum 31
 - Datum 31
 - Features 228
 - Marks 173
 - Material regarding QC-300 225
 - Registration form 11
 - Repackaging for shipment 11
 - Repeat delay 208
 - Report
 - Print a 26, 39
 - Formats 159
 - Reports 39, 201, 222
 - Reports are printed incorrectly 222
 - Requirements, setup 168
 - Resolution 172, 195
 - Responses, button 211
 - Restart distance 194
 - Results, report 143
 - Retaining feature data through a power cycle 192
 - Retrieving programs 153
 - Return to DRO threshold 207
 - RJ-45 connector 9
 - Roundness tolerance 135

- RS-232
 - Cable 229
 - Connector wiring 162 227
 - Port settings 224
 - Serial port 3, 8, 157, 158
- Runout tolerances 135
- S**
- Safety considerations 6
- Sales, contact Metronics 229
- Screen
 - Buttons 210
 - Clock 205
 - Digital positioner 214
 - Display 195
 - Encoders 172
 - Hardware 218
 - Header 201
 - Joystick 212
 - LED touch 13
 - Magnifications 186
 - Measure 191
 - Miscellaneous 207
 - Ports 204
 - Print 202
 - Probe path 215
 - Squareness 175
 - SLEC 176
 - Sound 206
 - Supervisor 170
- Screen
 - Contrast and brightness 209
 - Sensor cable 9
- Search distance 216
- Select
 - Axis to configure 172
 - Feature 127
 - Magnification 46
 - Setup parameter choices 166
 - Tolerance 37, 128
- Sending data to a computer 26, 158
- Sensor cable 9
- Separators, column 203
- Serial cable 224
- Serial port 158
- Settings, saving and loading 171
- Setup 24, 26, 163
- Setup
 - Parameter choices 166
 - Privileges 170
 - Requirements, minimum 168
 - Screens and functions 164
- Shipment 11
- Signed (+/-) distances 192
- Single view mode 197
- Skew
 - Alignment 54, 55
 - Measure a 142
 - Measuring a part 31
 - Part 29, 31
- Slec (segmented linear error correction) 174, 178
- Slots 60, 66, 131
- Sound screen 206
- Speaker jack outputs 2
- Specifications 225
- Speed, joystick motor 18, 199
- Squareness, calibration of stage 175
- Steps, inserting or appending new program 150
- Stop bits 204
- Stop recording 40, 144
- Storing a parameter 167
- Straightness tolerance 135
- Supervisor password 165, 170
- Surge suppressor 7
- Switching, display mode 197
- System and part condition 46

T

- Tab, extra 15, 16, 19, 198
- Tab, measure 14
- Tab, program 15
- Tabs, multiple extra 19
- Taltech winwedge© 229
- Teach, edge 47
- Temperature 225
- Temporary part fixturing 145
- Tests 225
- Text
 - Entry screen 141
 - Message 141
- Tilt front panel 3
- Time 205
- Time
 - Debounce 217
 - Formats 196
- Timeout delay 45, 194
- Tolerance 22, 29, 37, 125, 127
- Tolerance
 - Angle 136
 - Apply a 37, 143
 - Bidirectional 130
 - Bonus 133
 - Concentricity 135
 - Editing 148
 - MMC 133
 - LMC 134
 - Parallelism 136
 - Perpendicularity 136
 - Report 29
 - Runout 135
 - Roundness 135
 - Screen 127
 - Straightness 135
 - True position 132
 - Width 137
- Tools, programming 15

Touchscreen

- Calibration rows and columns 207
- Cursor 208
- Repeat delay 208
- Zone size 209

Transients 7

Troubleshooting list 219, 224

True position tolerance 132

Types

- Report 202
- Tolerance 130

U

- Unauthorized personnel 170
- Undo 24
- Unit of measure 24, 196, 221
- Unpacking the QC-300 5
- USB
 - Port 3, 160
 - Printers 159
 - Message 141

V

- Values, edge detector 217
- Velocity, axis 212, 213, 214
- View 22

W

- Warranty information 11
- Weight 225
- Width tolerance 137
- Winwedge© 229
- Wiring 6, 226
- Word length 204

Z

- Zero, machine 173

HEIDENHAIN

DR. JOHANNES HEIDENHAIN GmbH

Dr.-Johannes-Heidenhain-Straße 5

83301 Traunreut, Germany

☎ +49 8669 31-0

FAX +49 8669 5061

E-mail: info@heidenhain.de

www.heidenhain.de